

PROJECT DETAILS	
Project No.	111111
Region	Uttar Pradesh
City	Lucknow
Plot No.	111111
Block No.	111111
Phase No.	111111
Client Name	Shikhar Kumar & Shakuntala Devi
Project Name	Proposed Residential Building
Project Address	Kuru-Gumla Road, Kiskoo More, Lucknow
Project Status	Approved
Approval No.	111111
Approval Date	11/11/2024
Project Manager	Shikhar Kumar
Architect	Shikhar Kumar & Shakuntala Devi
Scale	1:100
Sheet No.	01 OF 01
Revision	01
Prepared By	Shikhar Kumar
Checked By	Shakuntala Devi
Approved By	Shikhar Kumar
Date	11/11/2024

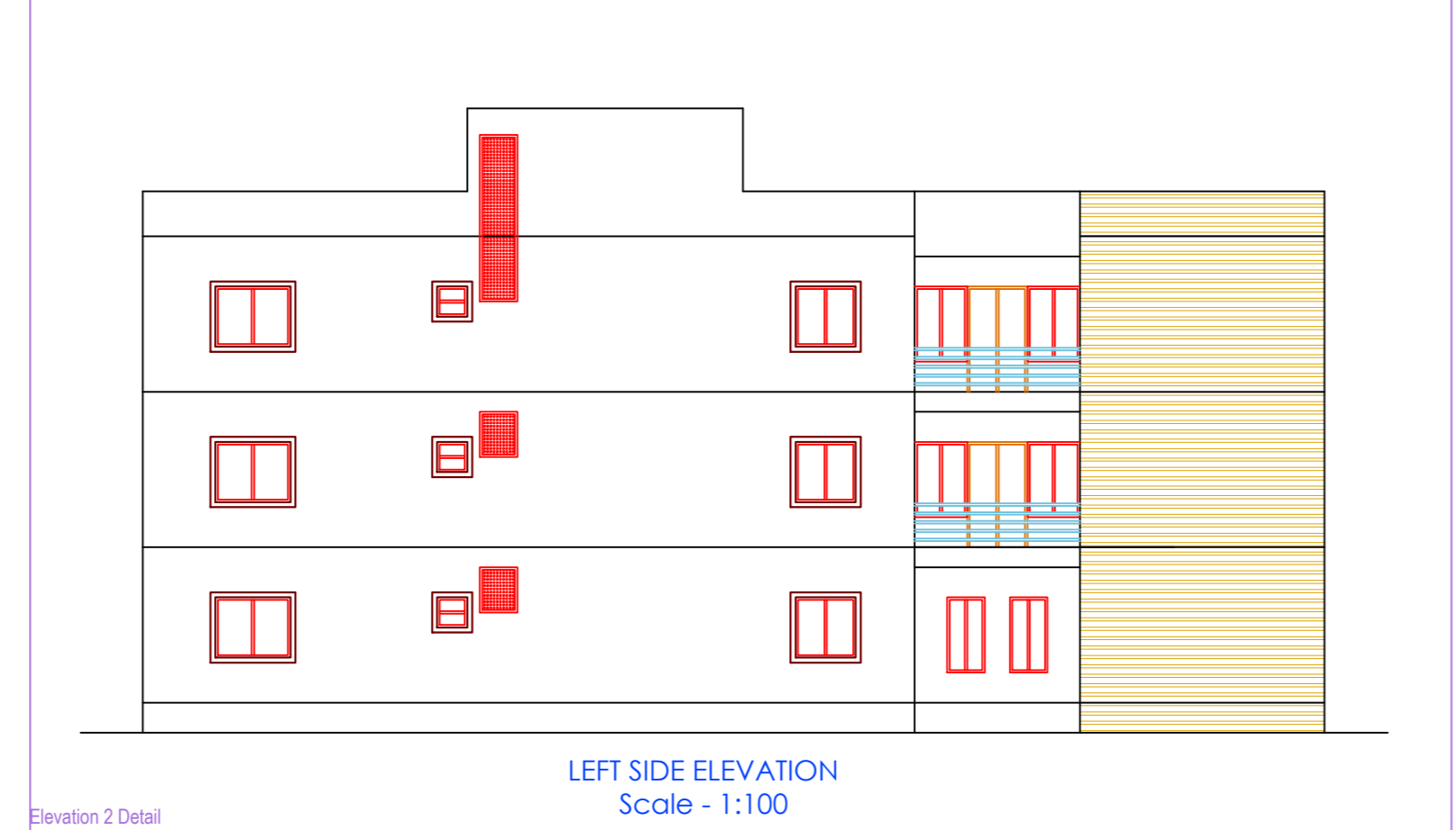

General notes

- ALL DIMENSION ARE IN MILLIMETRES UNLESS OTHERWISE STATED.
- NO DIMENSION IS TO BE SCALED OFF THE DRAWING.
- DRAWINGS TO BE READ IN CONJUNCTION WITH ALL RELEVANT DRAWINGS & SPECIFICATIONS.
- REFER WRITTEN DIMENSIONS ONLY.
- DOORS AND WINDOW FRAME NOT TO BE FIXED ALONG WITH BRICK WORK.
- INTERNAL PLASTER SHOULD BE 12MM THICK AND EXTERNAL PLASTER IS 25MM THICK.
- FOUNDATION DEPTH UP TO GOOD SOIL.
- CEMENT MORTAR OF MIX (1:4) FOR ENTIRE STRUCTURE AND PLASTER WORK.
- SEPTIC TANK WILL BE FLUSHING SYSTEM.
- ALL REINFORCEMENT SHALL BE OF TOR STEEL OF GRADE FY-415.
- GRADE OF CONCRETE SHALL BE M-20

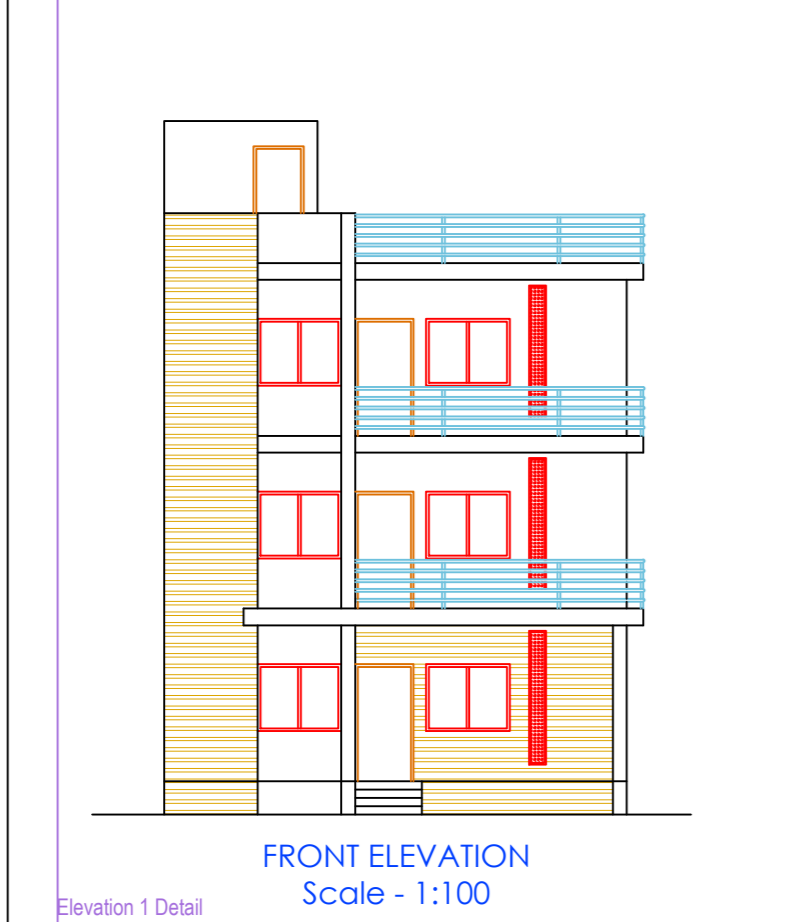
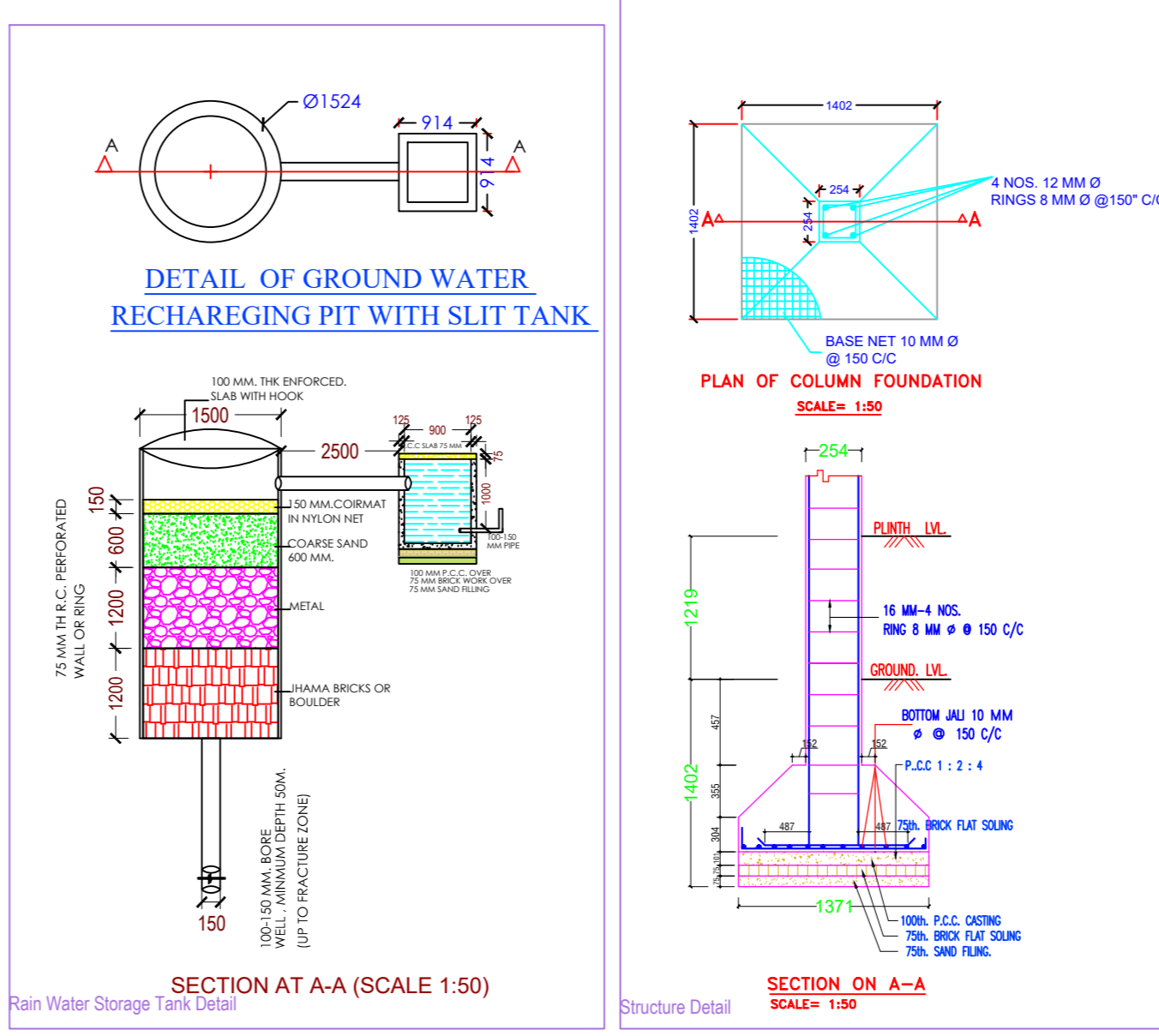
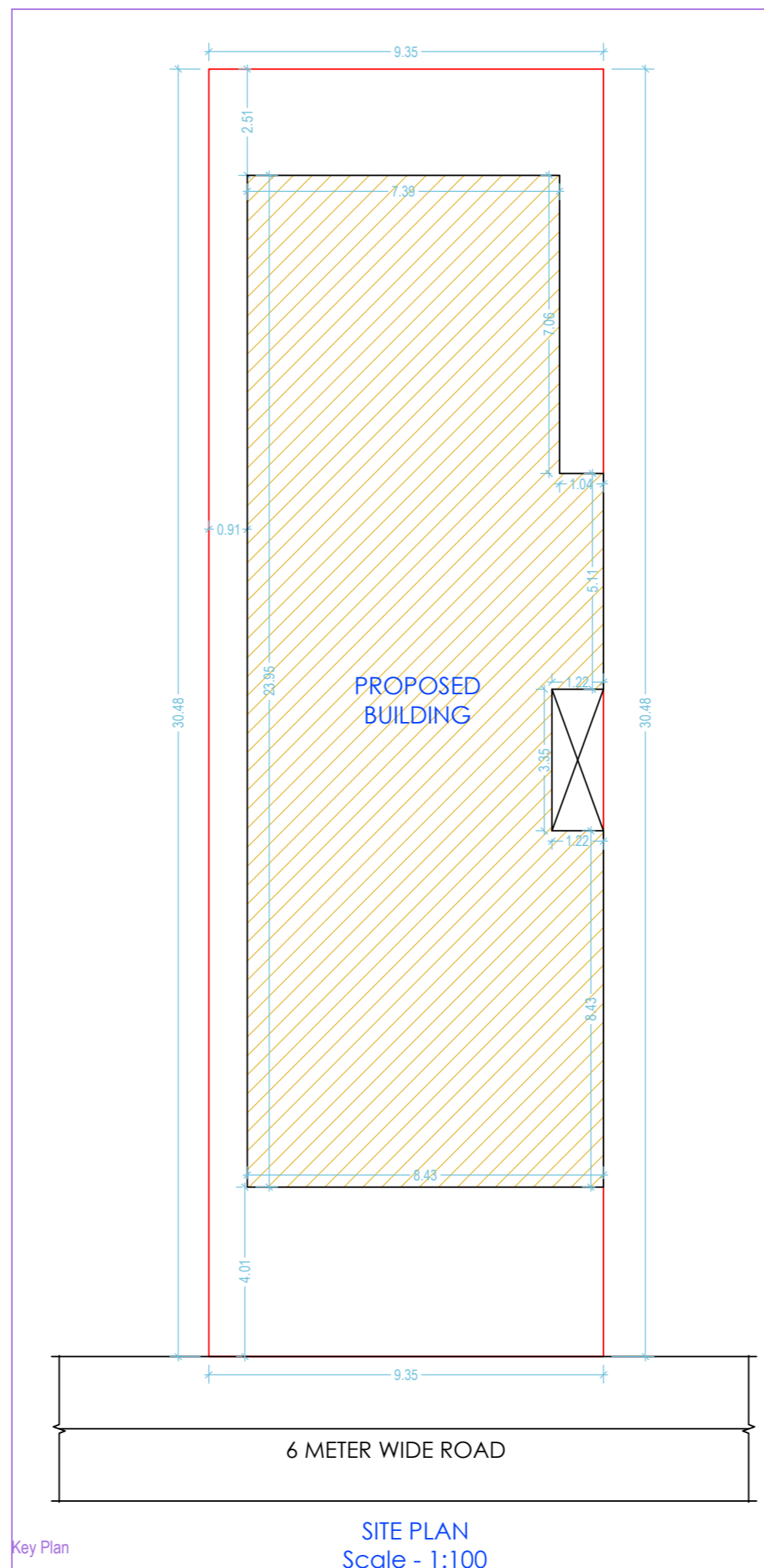
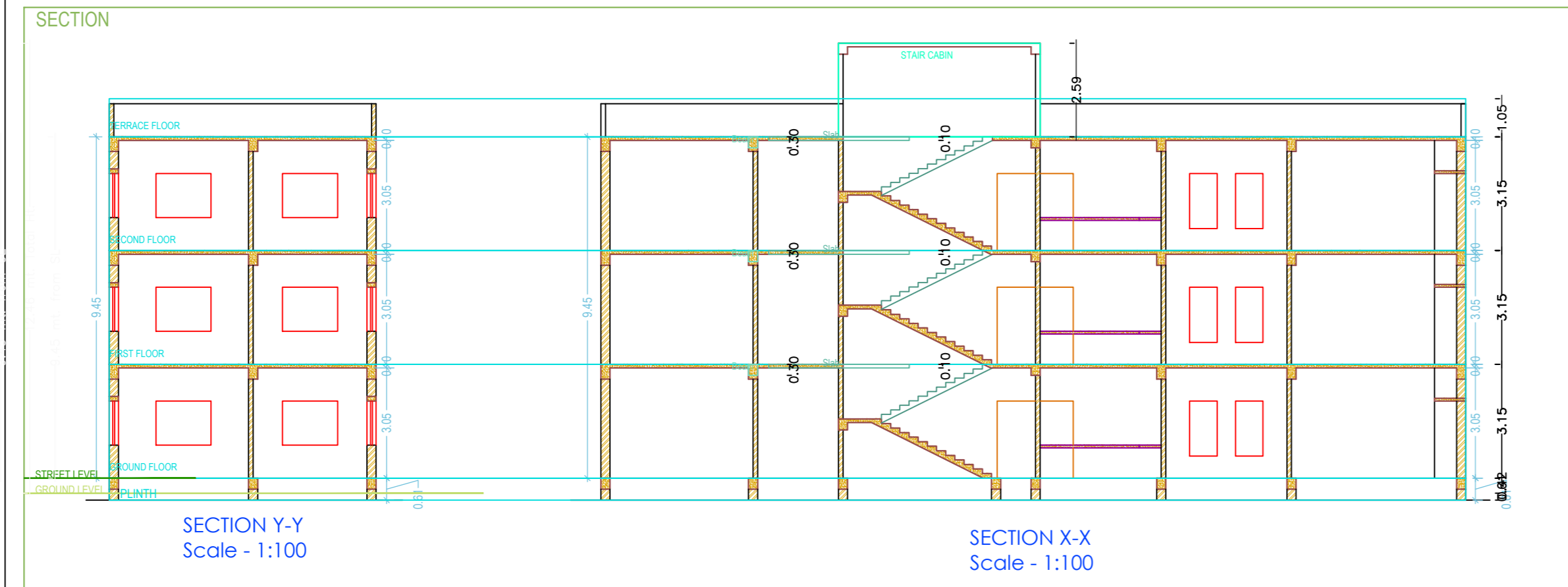
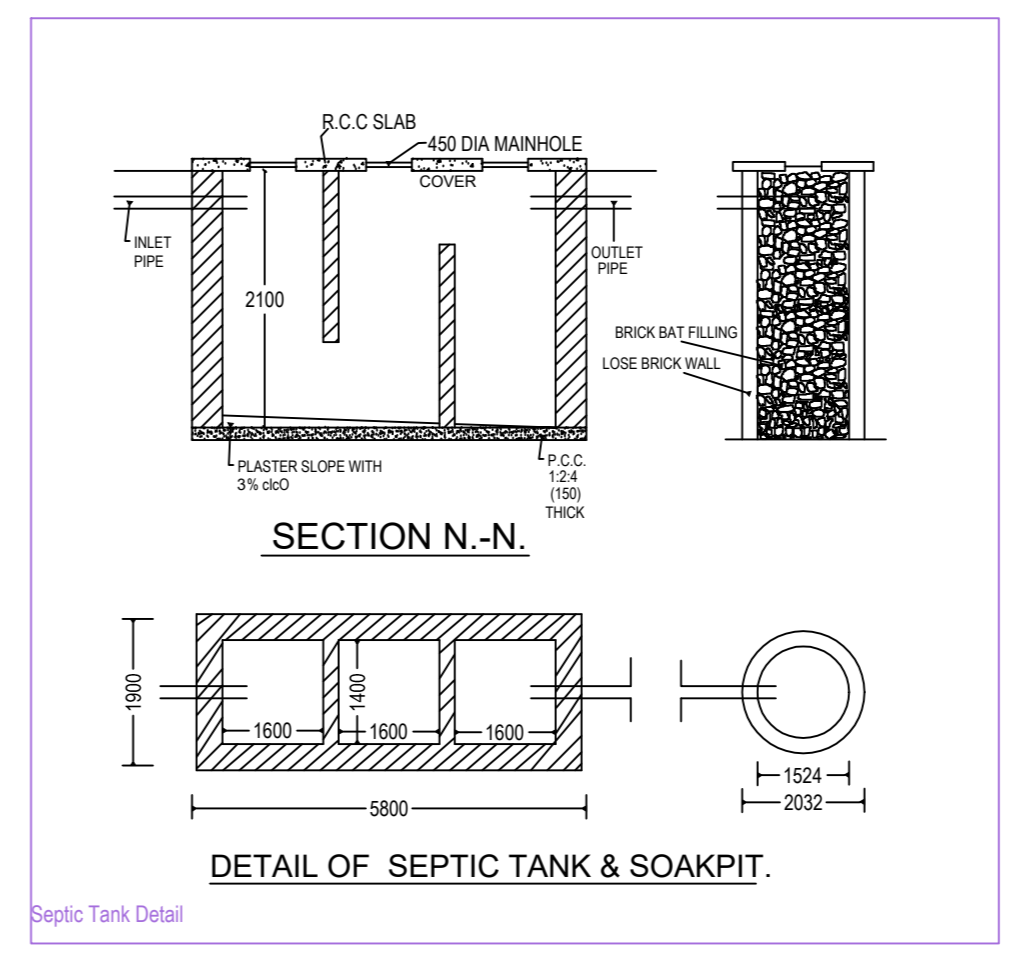

TYPE	WIDTH	HEIGHT	SILL LVL.	DISCRPTION
D	1050	2100	NILL	SINGLE SHUTTER FLUSH DOOR
D1	900	2100	NILL	" "
W	1200	1200	900	4 LEAF GLAZED WIND
W1	900	1200	900	" "
V	600	600	2400	VENTILATOR

Schedule of area

PLOT AREA AT DEED - 284.90 SQ.M.
 AREA OF GROUND FLOOR - 190.54 SQ.M.
 AREA OF FIRST FLOOR - 175.48 SQ.M.
 AREA OF SECOND FLOOR - 175.48 SQ.M.
 TOTAL COVERED AREA - 541.50 SQ.M.
 % OF COVERED AREA - 66.87%
 TOTAL F.A.R. ACHIEVED - 1.9

PROPOSED RESIDENTIAL BUILDING PLAN OF
 1 SHEKHAR KUMAR S/O SHIV KUMAR
 2, SHAKUNTALA DEVI W/O BHUPNATH SAHU,
 R.S. PLOT NO. - 988, KHATA NO. - 147,
 THANA NO. - 141, WARD NO. - 02,
 AREA- 07 DECIMALS,
 VILLAGE - KUTMU, THANA - LOHARDAGA
 DIST- LOHARDAGA - 835302,
 STATE - JHARKHAND

SCALE	DATE	SHEET NO.
1:100		01 OF 01

CLIENT		ENGINEER / ARCHITECT	
SHEKHAR KUMAR & SHAKUNTALA DEVI		SHEKHAR KUMAR & SHAKUNTALA DEVI	

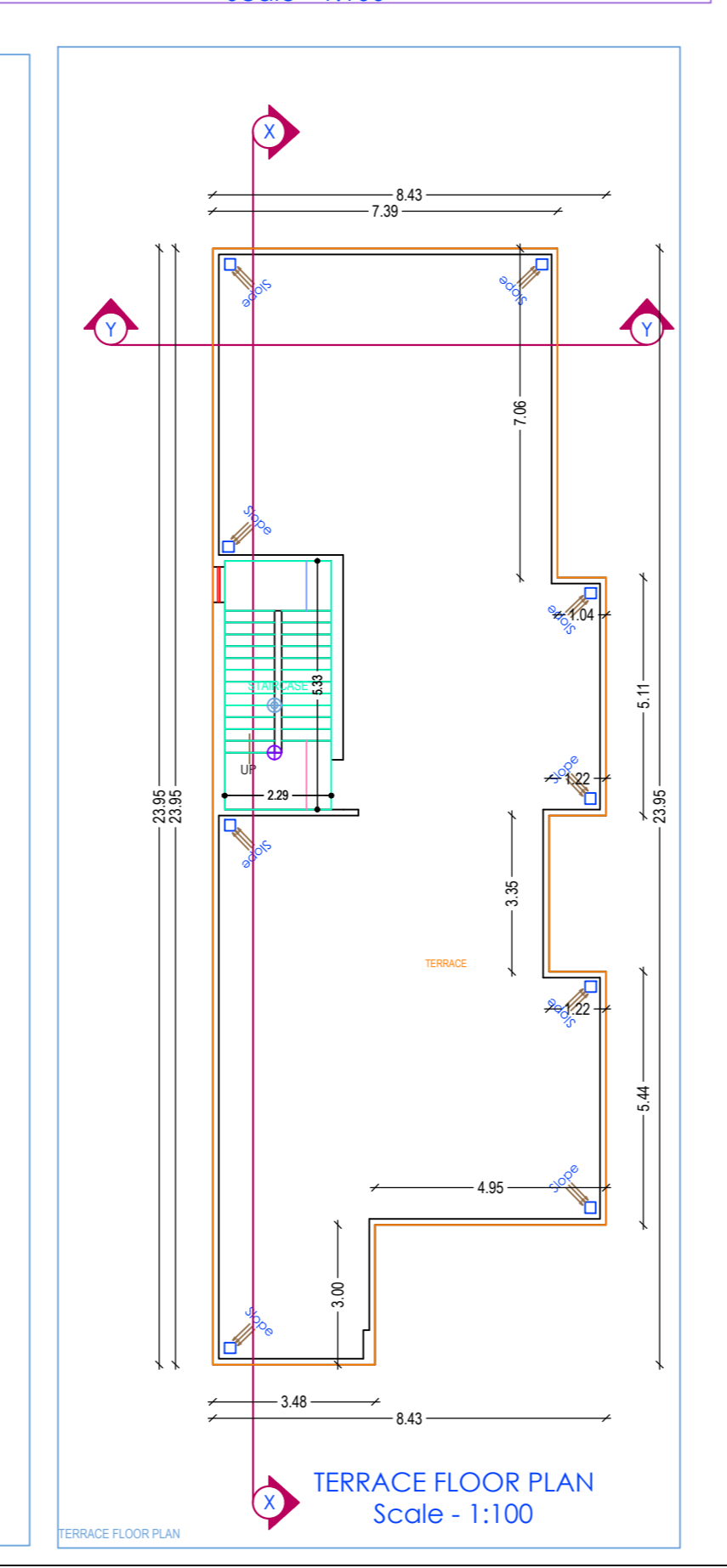
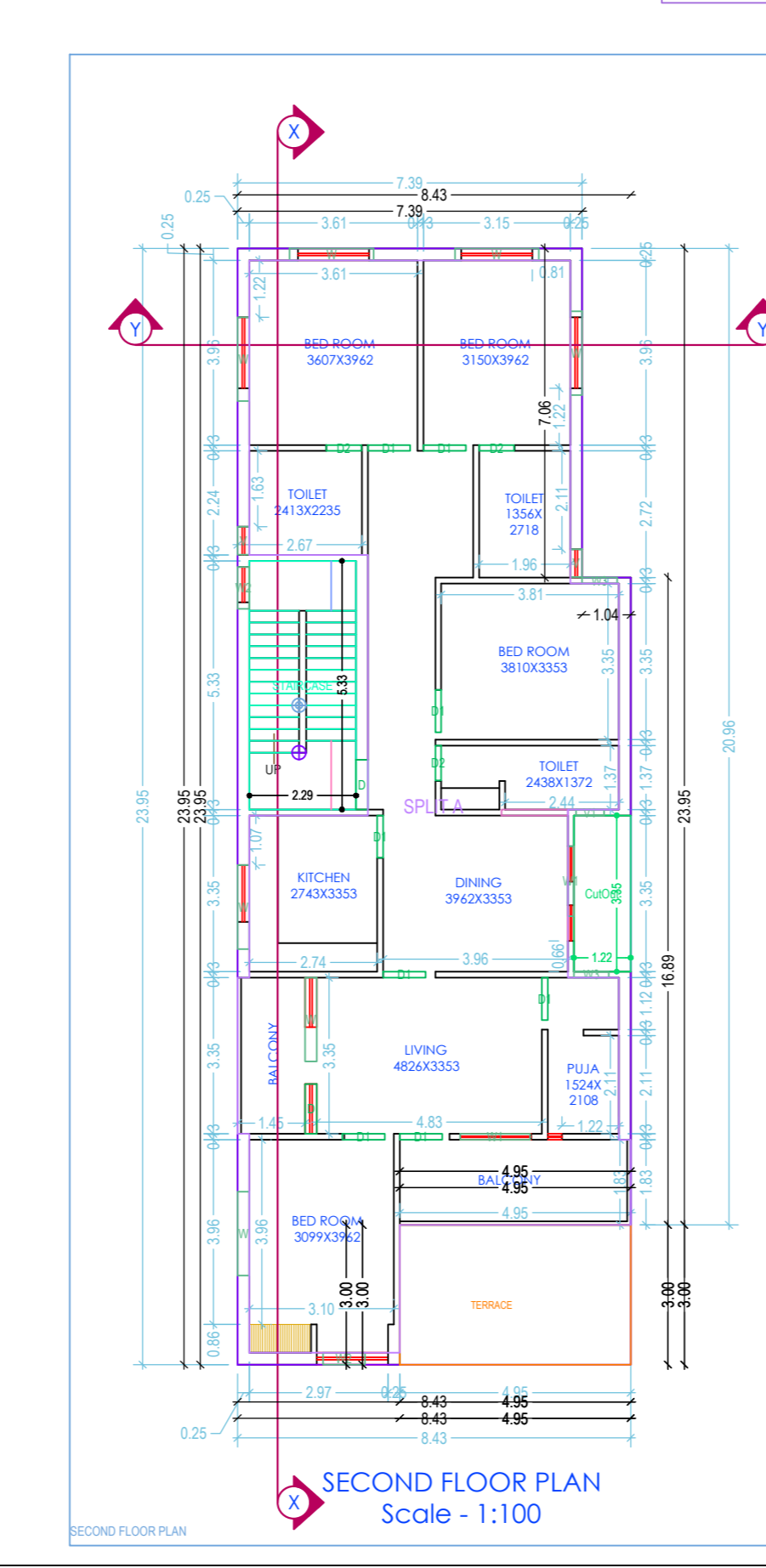
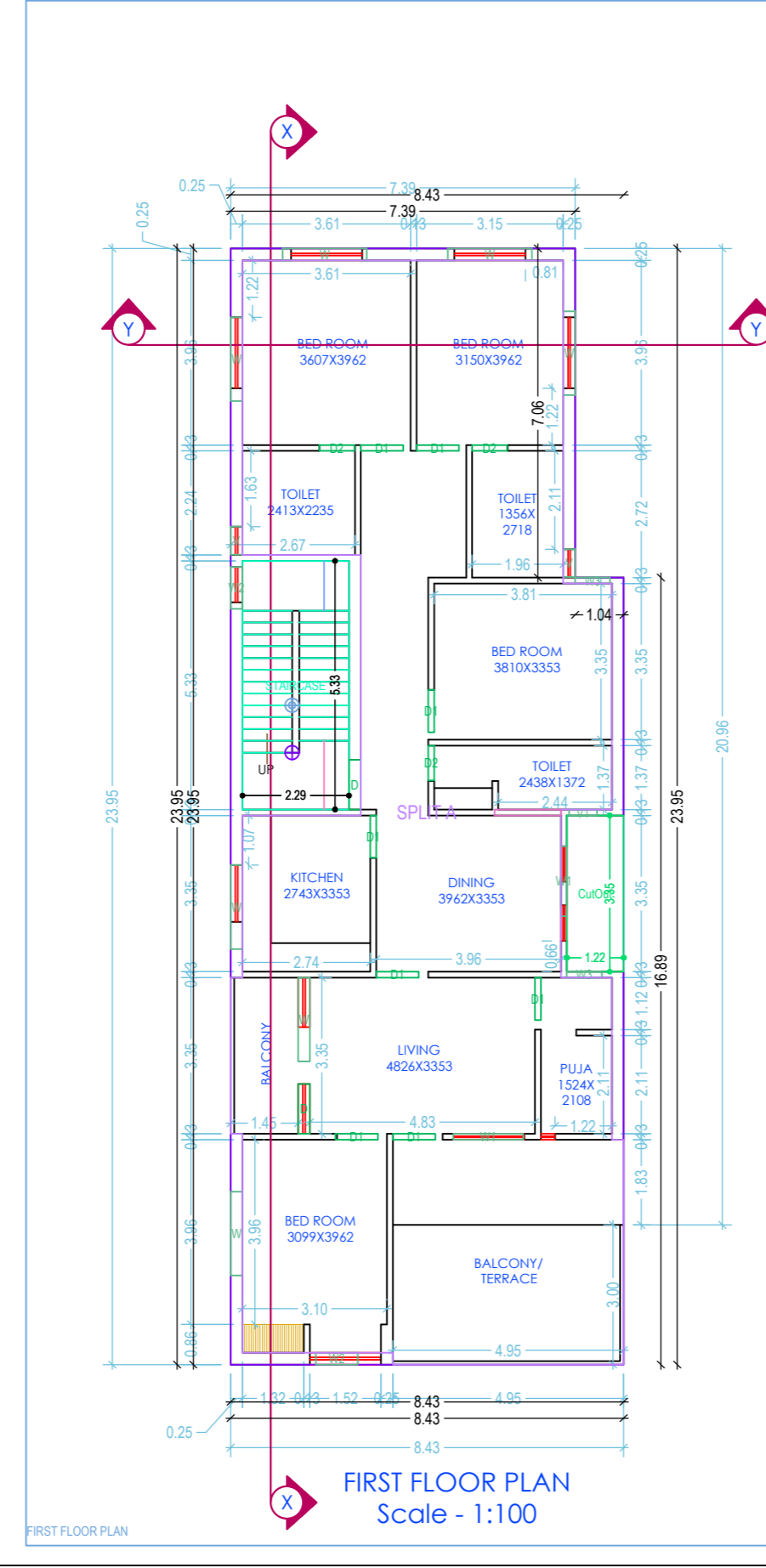
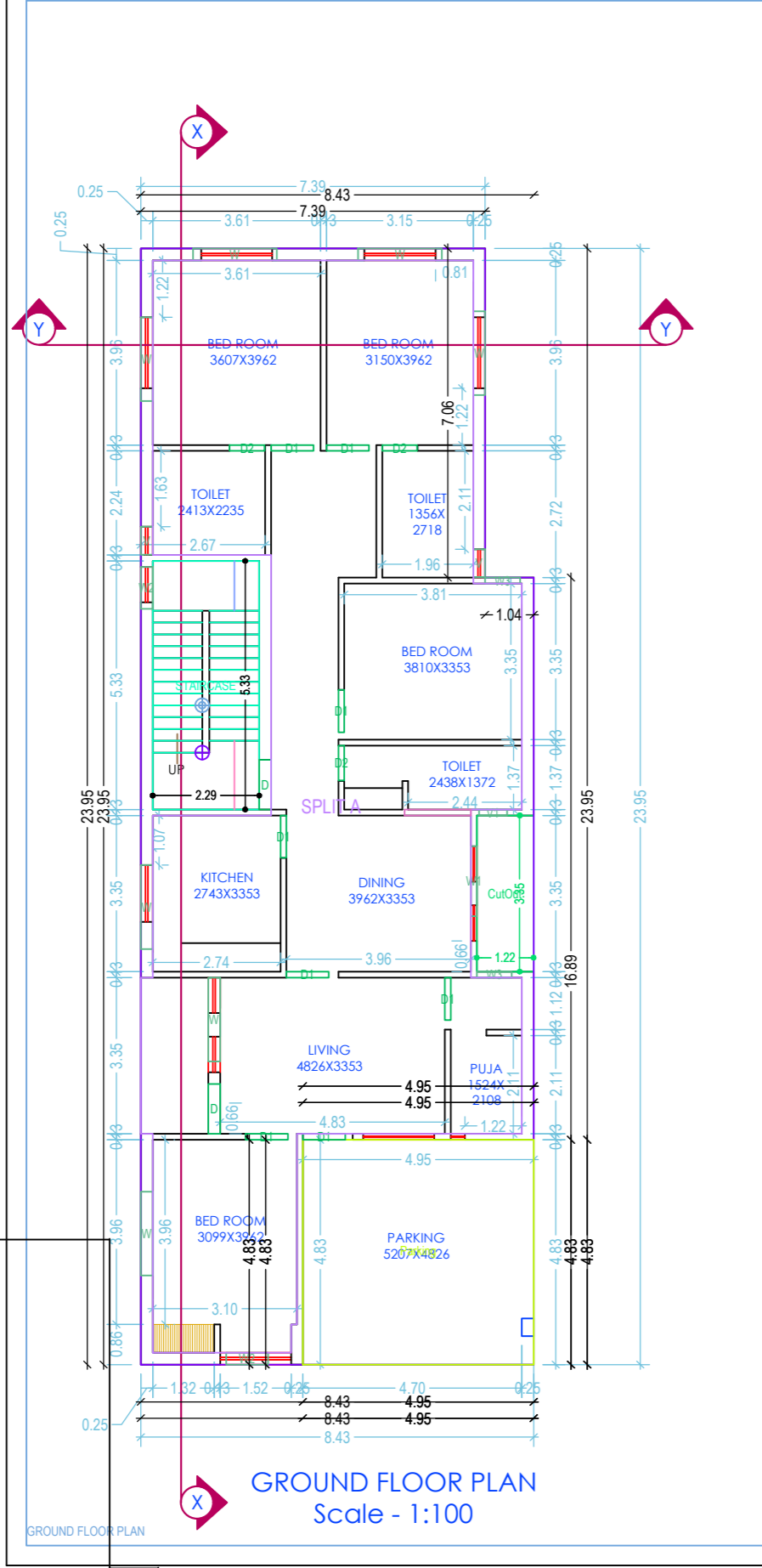
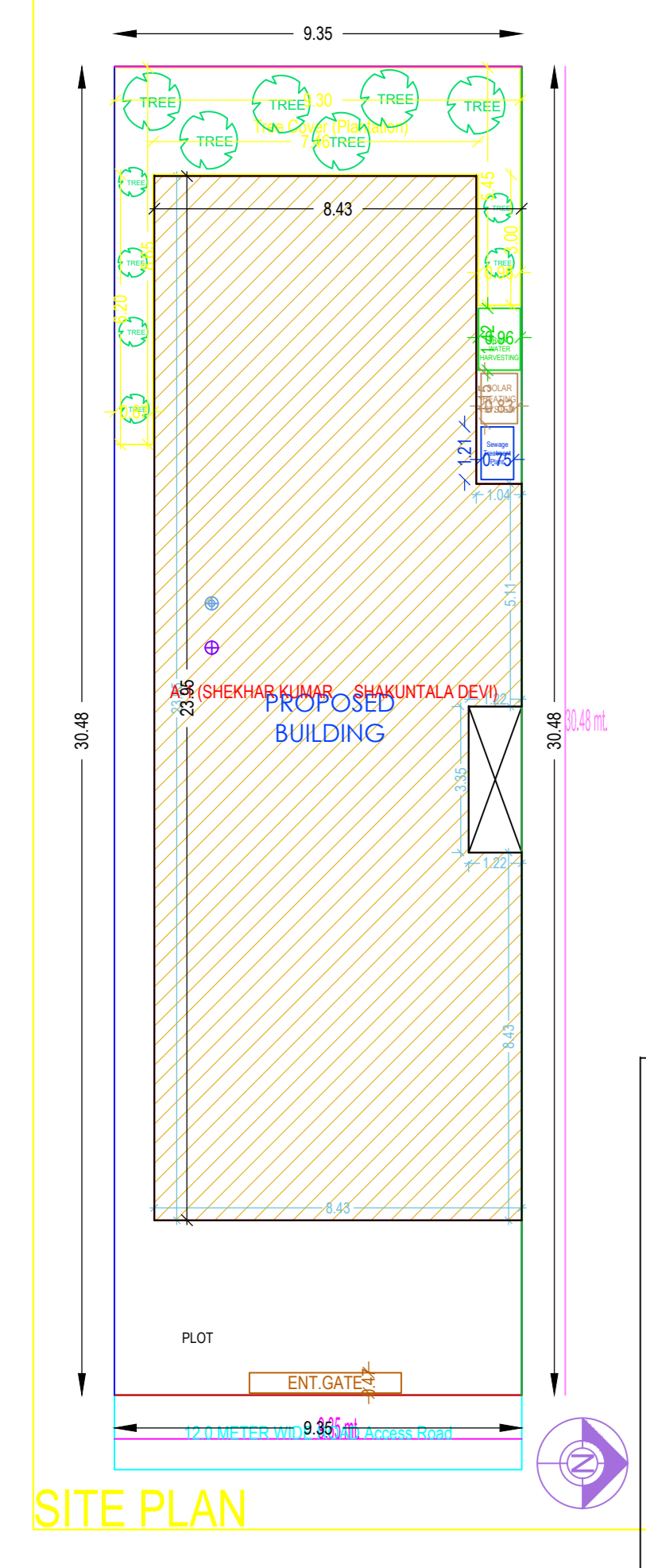

Building A (SHEKHAR KUMAR SHAKUNTALA DEVI)

Floor Name	Gross Built-up Area	Net Built-up Area	Net Floor Area	Net Plotted Area	Total F.A.R. Area	F.A.R. (No.)
Ground Floor	190.54	190.54	190.54	190.54	190.54	01
First Floor	175.48	175.48	175.48	175.48	175.48	02
Second Floor	175.48	175.48	175.48	175.48	175.48	02
Terrace	0.00	0.00	0.00	0.00	0.00	00
Total	541.50	541.50	541.50	541.50	541.50	07

SCHEDULE OF JOINERY

ITEM NO.	NAME	LENGTH	HEIGHT	NO.
1	WOODEN DOOR	0.9	2.1	08
2	WOODEN WINDOW	1.2	1.5	24
3	WOODEN WINDOW	1.2	1.5	06
4	WOODEN WINDOW	0.9	2.1	08
5	WOODEN WINDOW	1.2	1.5	05
6	WOODEN WINDOW	1.8	2.1	21
7	WOODEN WINDOW	0.9	2.1	06

SCHEDULE OF JOINERY

ITEM NO.	NAME	LENGTH	HEIGHT	NO.
8	WOODEN WINDOW	0.9	2.1	03
9	WOODEN WINDOW	0.9	2.1	06
10	WOODEN WINDOW	0.9	2.1	06
11	WOODEN WINDOW	0.9	2.1	06
12	WOODEN WINDOW	0.9	2.1	06
13	WOODEN WINDOW	0.9	2.1	06
14	WOODEN WINDOW	0.9	2.1	06
15	WOODEN WINDOW	0.9	2.1	06
16	WOODEN WINDOW	0.9	2.1	06
17	WOODEN WINDOW	0.9	2.1	06
18	WOODEN WINDOW	0.9	2.1	06
19	WOODEN WINDOW	0.9	2.1	06
20	WOODEN WINDOW	0.9	2.1	06

UnBIA Table for Building A (SHEKHAR KUMAR SHAKUNTALA DEVI)

FLOOR	Name	SHK/TA	UnBIA Area	Cover Area	No. of Rooms	No. of Corridor
GROUND FLOOR	FLAT	SHK/TA	491.50	491.50	12	1
TOTAL			491.50	491.50	12	1