

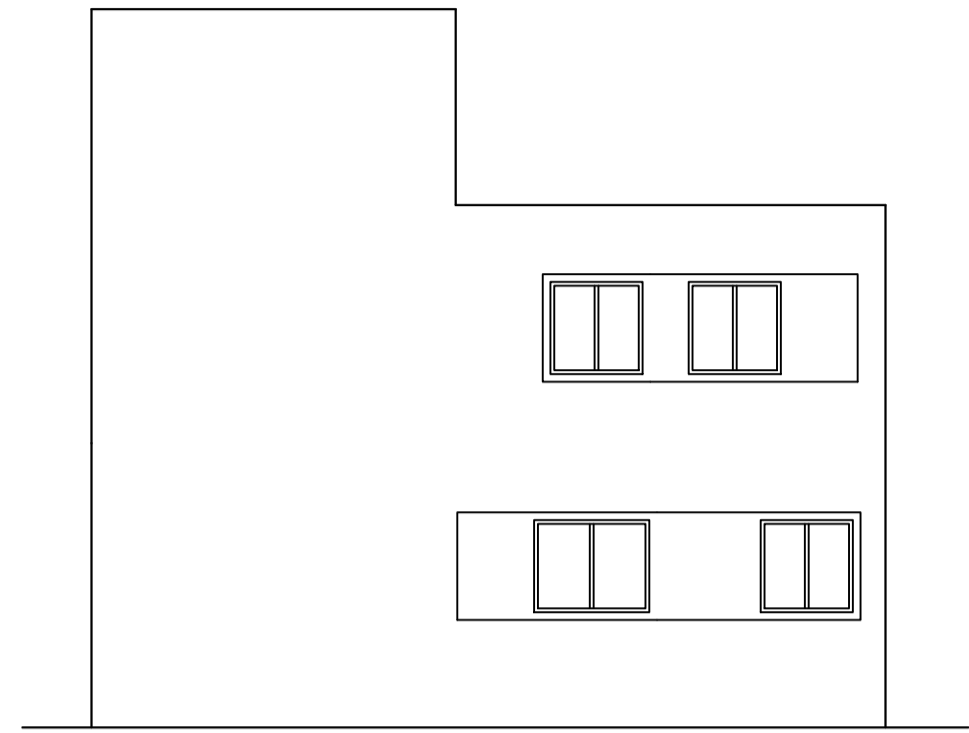

Proposal Basic Information	
Proposal File No.	LNP/BP/0012/W03/2019
Owner Name	RINA SARAF
Khata No	54
Plot No	54
Village Name	Nadia
Use	Residential
SubUse	Bungalow/ Dwelling / Non Apartment

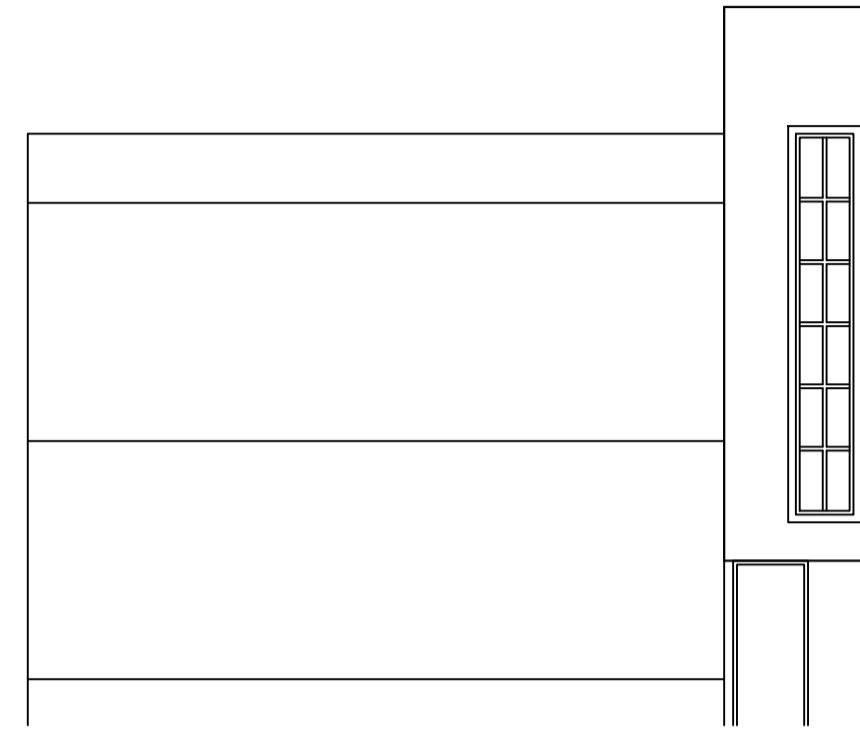

RIGHT SIDE ELEVATION  
Scale - 1:100



FRONT ELEVATION  
Scale - 1:100

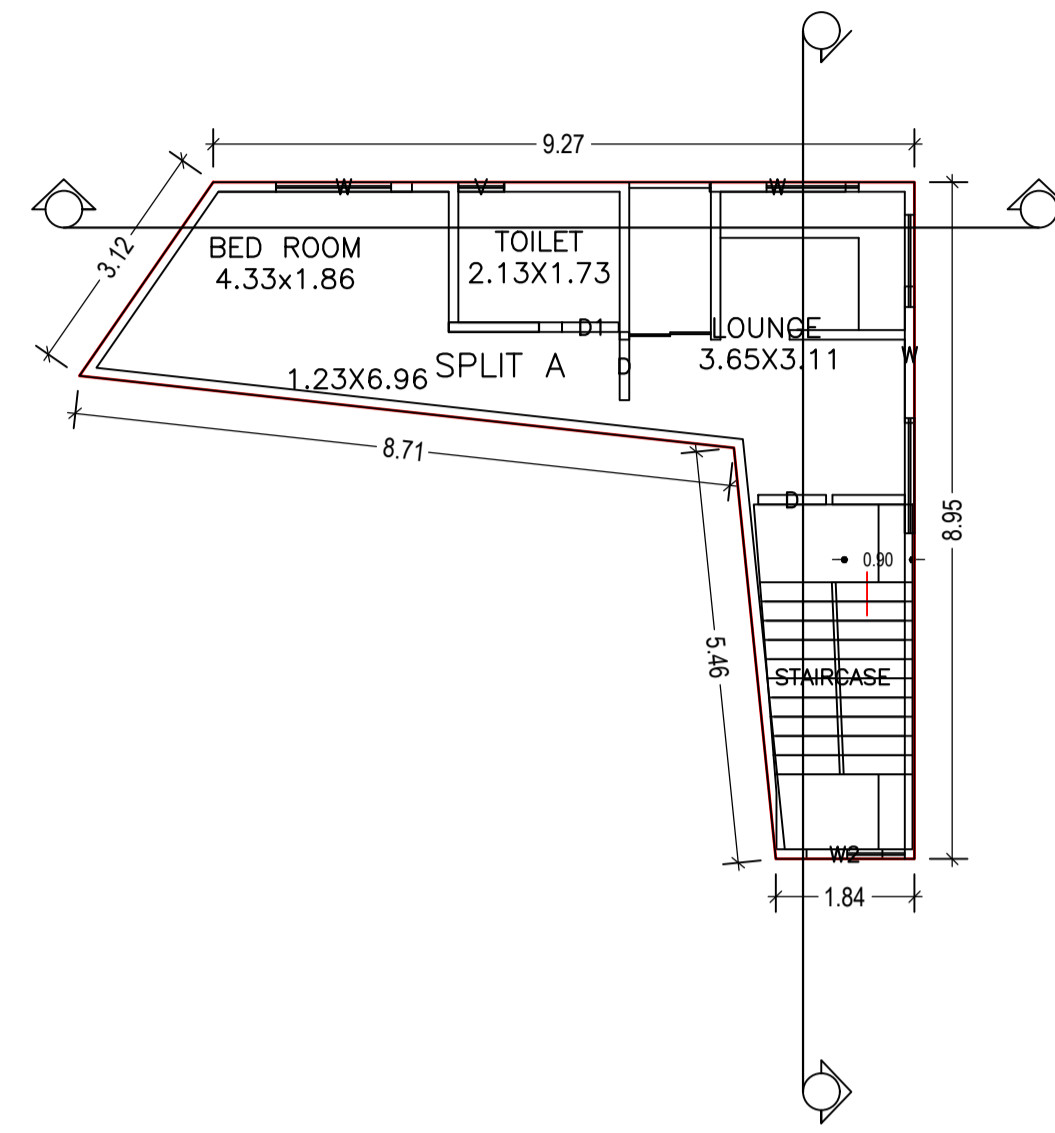

FIRST FLOOR PLAN  
(Proposed)  
(SCALE 1:100)

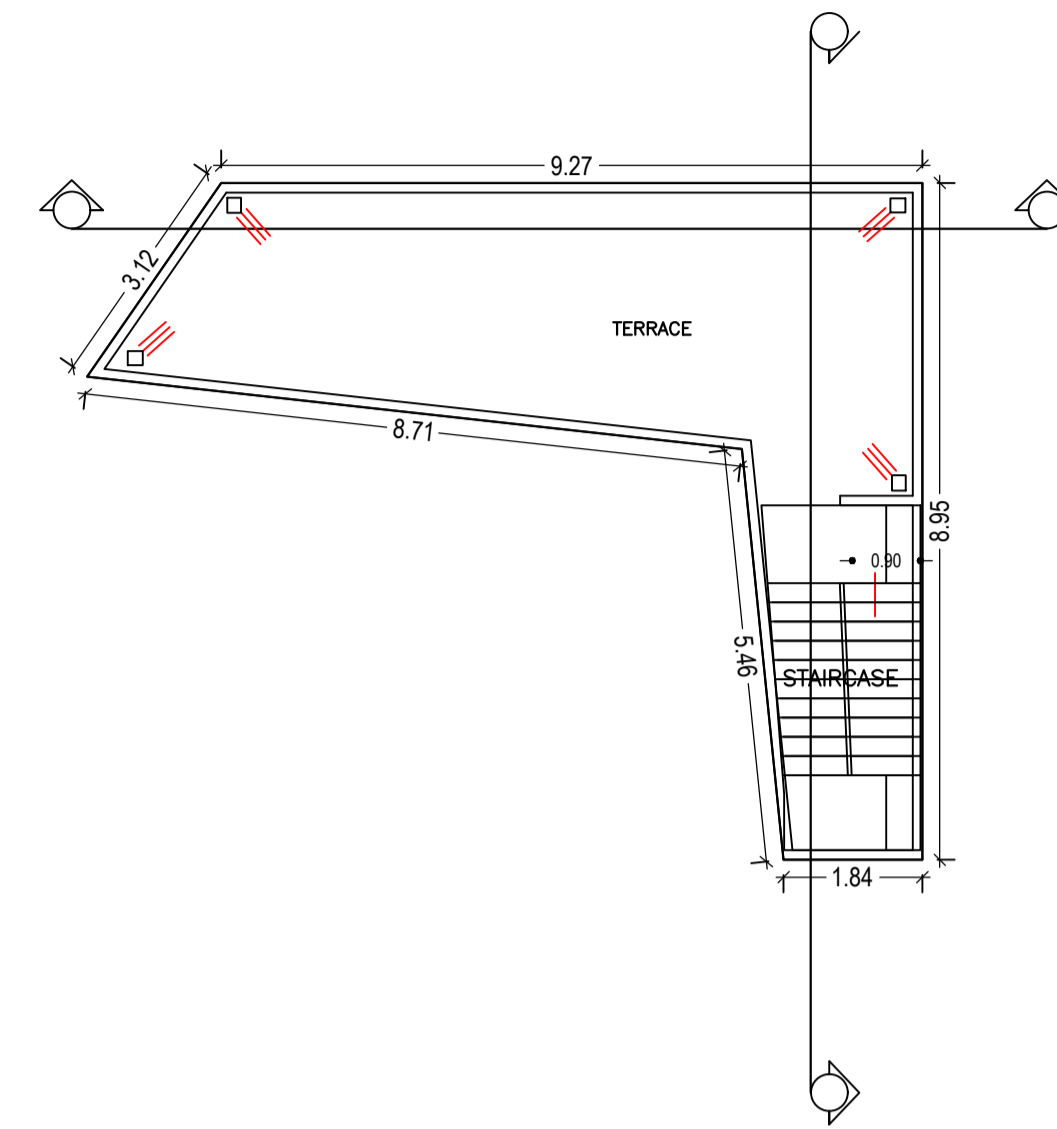

TERRACE FLOOR PLAN  
(SCALE 1:100)

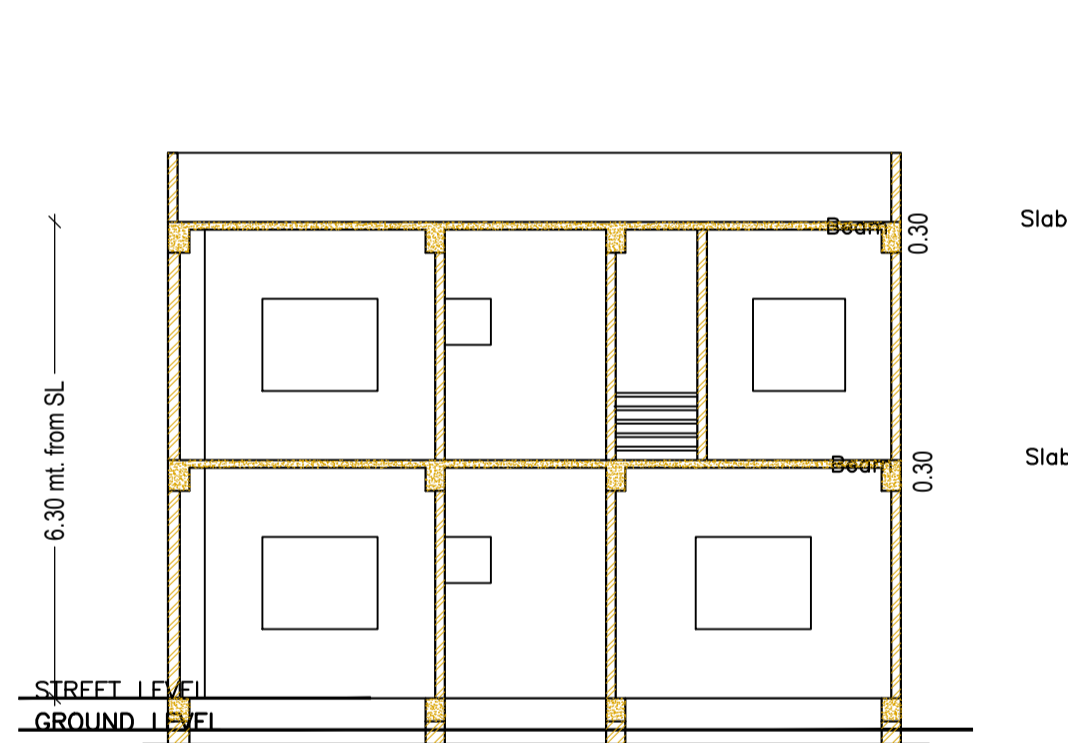

SECTION X-X  
Scale - 1:100

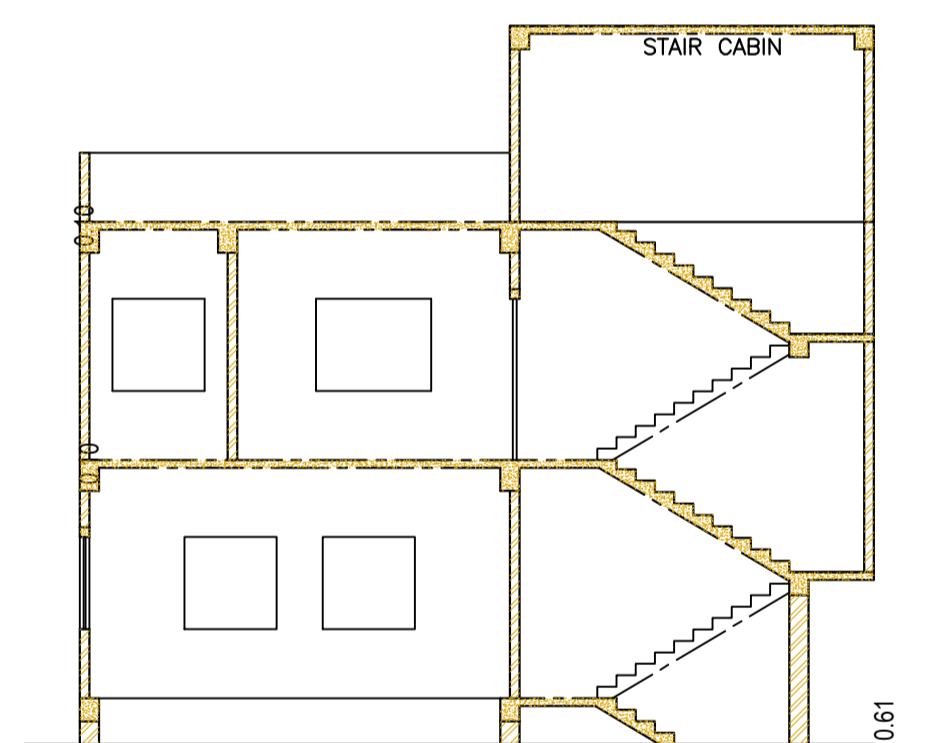

SECTION Y-Y  
Scale - 1:100

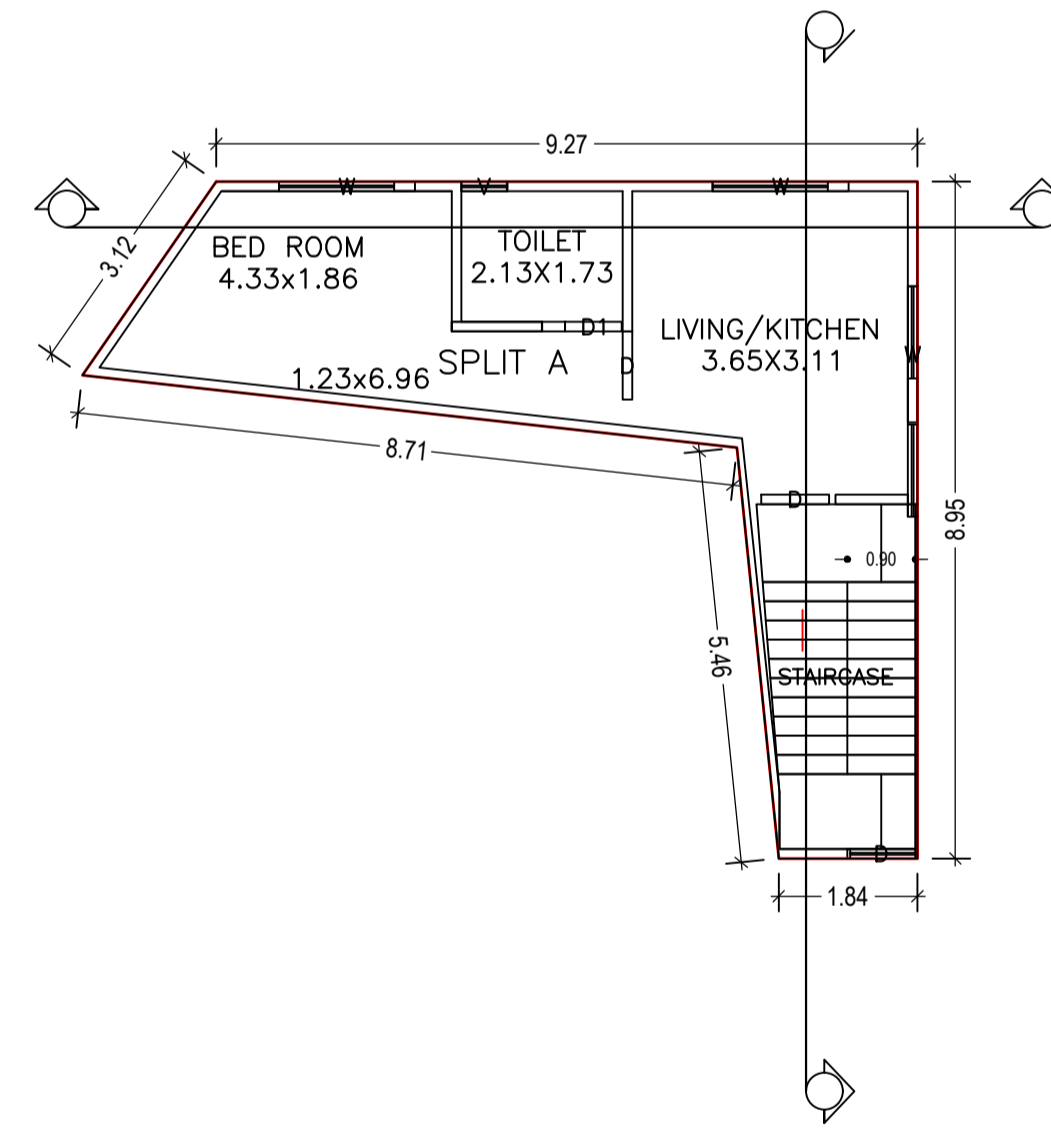

GROUND FLOOR PLAN  
(Proposed)  
(SCALE 1:100)

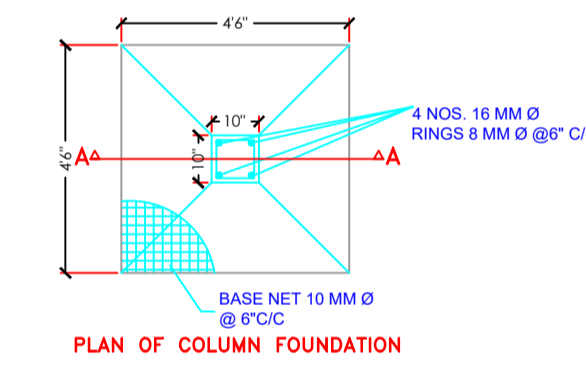

PLAN OF COLUMN FOUNDATION  
SCALE= 1:50

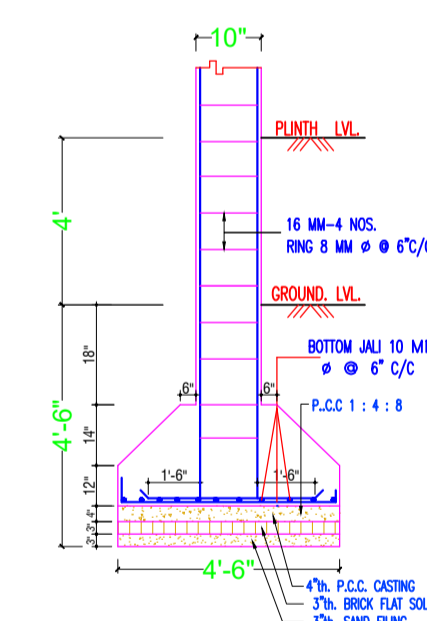

SECTION ON A-A  
SCALE= 1:50

UnitBUA Table for Building :A (SMT RINA SARAF)

FLOOR	Name	UnitBUA Type	UnitBUA Area	Carpet Area	No. of Rooms	No. of Tenement
GROUND FLOOR PLAN	SPLIT A	FLAT	61.33	61.03	3	1
FIRST FLOOR PLAN	SPLIT A	FLAT	0.00	0.00	3	0
Total:	-	-	61.33	61.03	6	1

LTP NAME AND SIGNATURE	STRUCTURAL ENG'S NAME AND SIGNATURE	BUILDER NAME AND SIGNATURE	DIGITAL SIGNATURE
ASHWINI KUMAR SAHU LNP/ENG/0005/2017			