

Project Title : SMT, LALAWATI DEVI

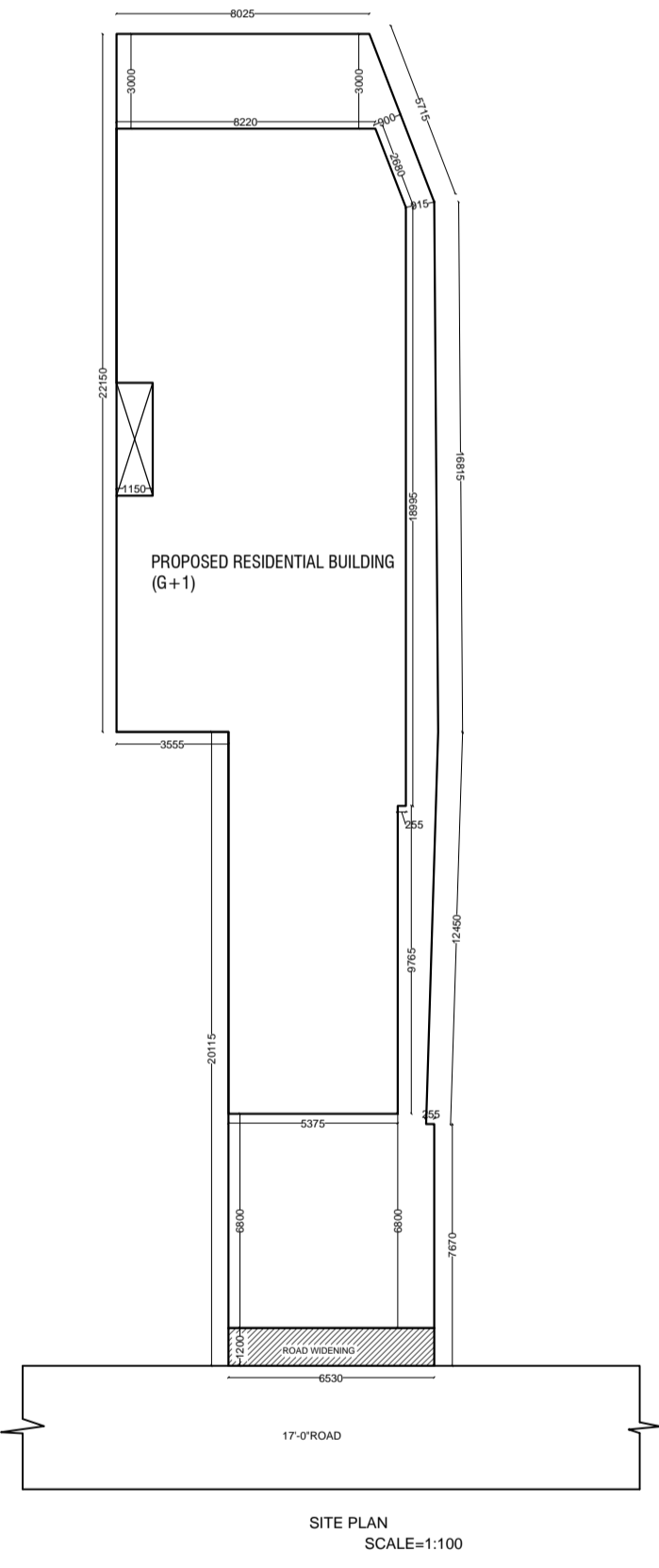
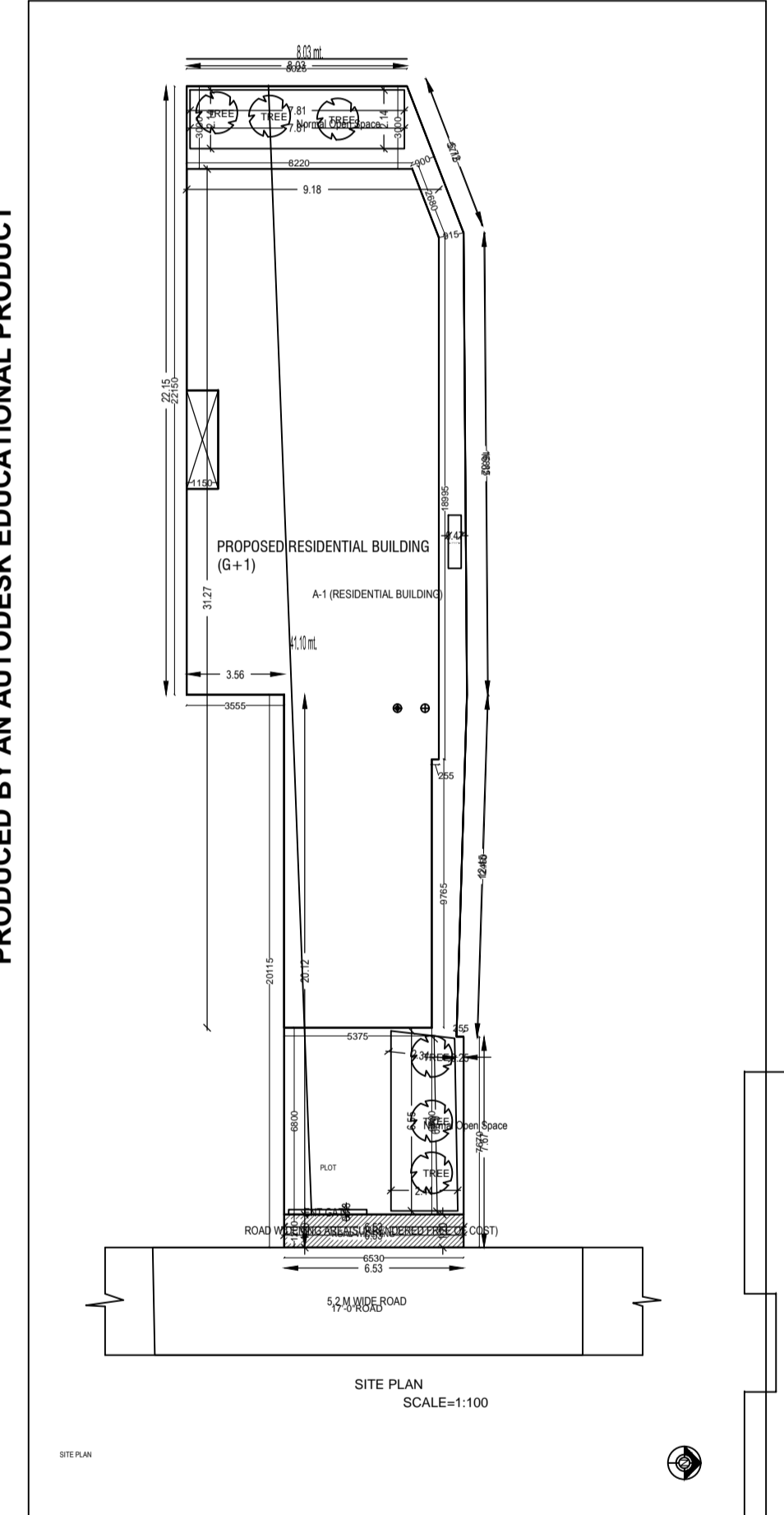
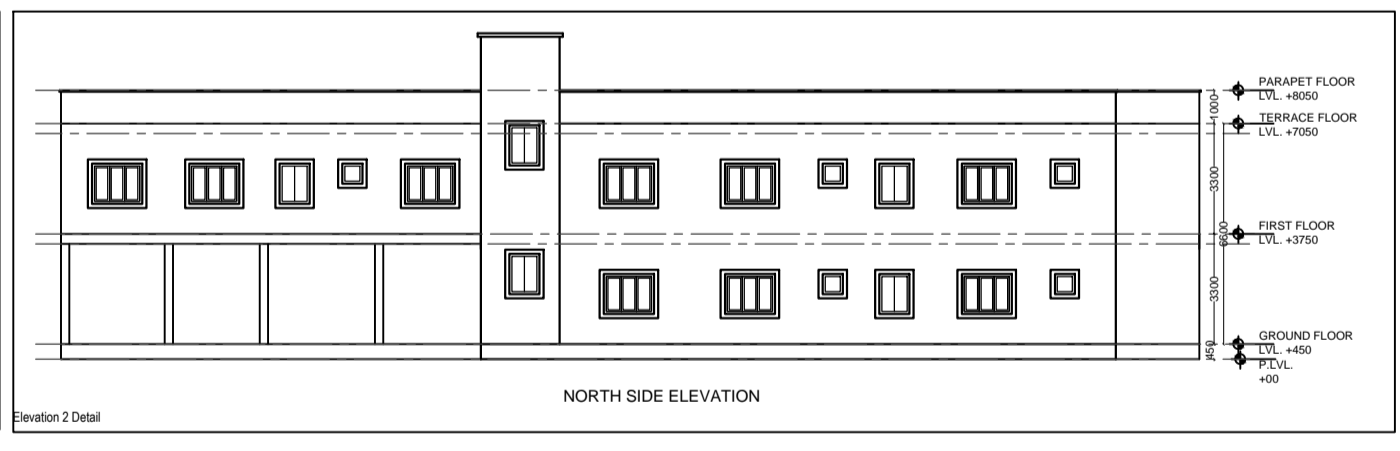
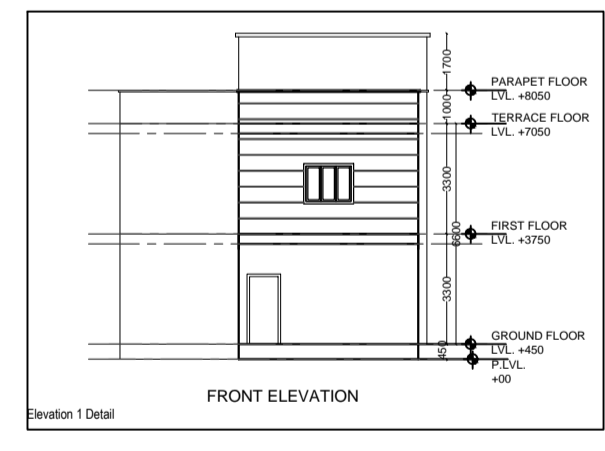
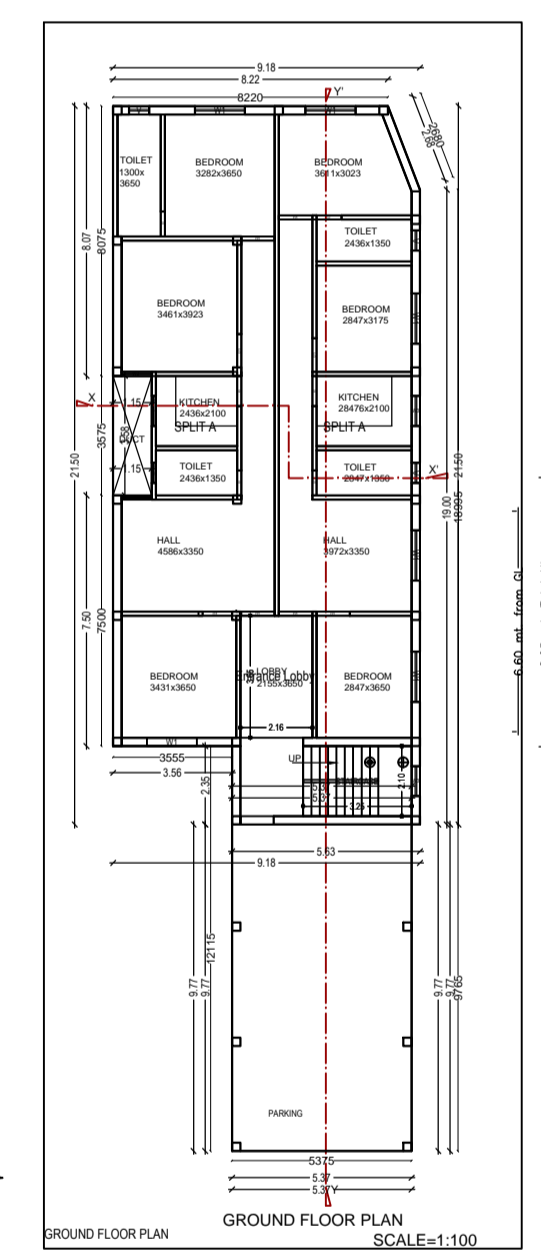
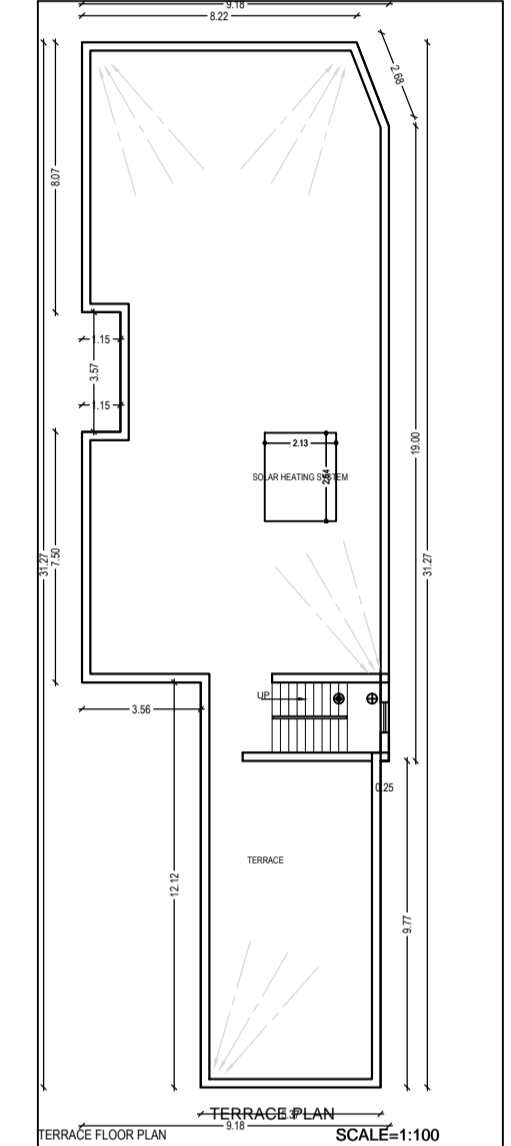
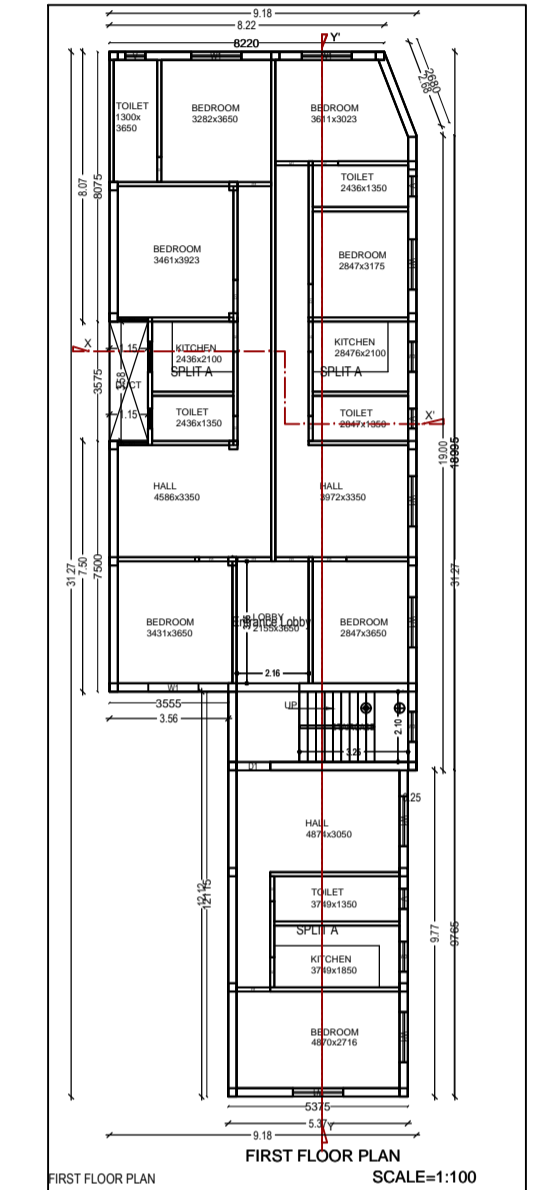
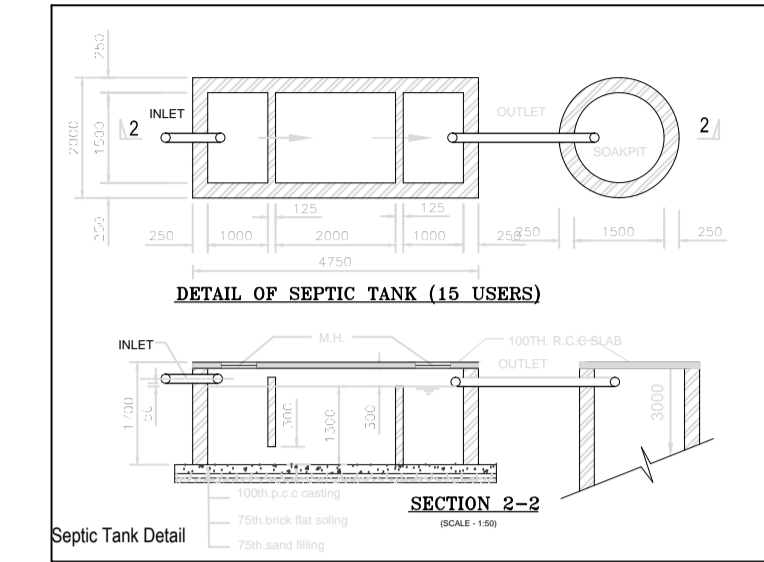
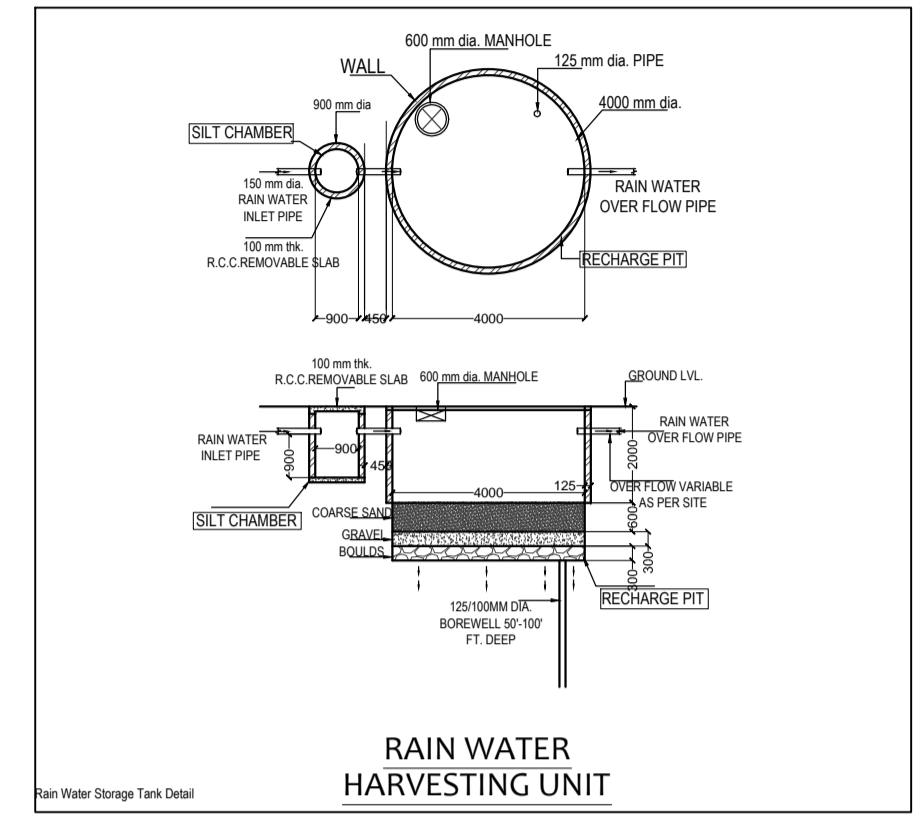
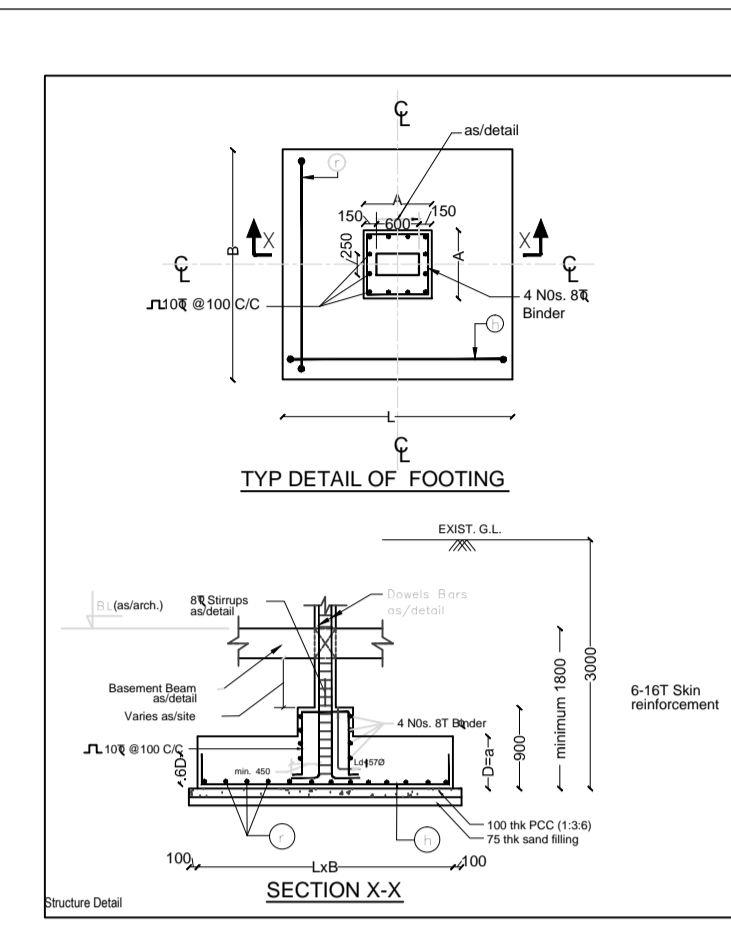

NOTE- ALL DIMENSION ARE IN MILLIMETERS

- SPECIFICATIONS**
- FOUNDATION - R.C.C. FRAME STRUCTURE
 - WALLS - 1st CLASS BRICK WORK IN RED BRICK IN CEMENT MORTAR 1:6
 - ALL R.C.C. WORK IN M20 GRADE CONCRETE & Fe 500 GRADE STEEL
 - FLOORING - VITRIFIED/CERAMIC TILES
 - R.C.C. ROOF SLAB 100MM THK IN M20
 - STAR WAST SLAB 100MM THK, STEPS 300 X 150.
 - CHALKALTA 12MM THK 0.6 WIDE IN R.C.C. SLAB
 - PLASTER OUTER 25MM-1 & INSIDE 12MM-1 & CEILING 8MM-1 & 4
 - WOOD WORK 22 MM THK FLUSH DOORS, WINDOWS IN STEEL GLAZED ALUMINIUM GLAZED AS PER DESIGN
- DOOR / WINDOW SCHEDULE**
- | Sl. No. | Door / Window | Size (mm) | Qty |
|---------|---------------|-------------|-----|
| 1 | DOOR | 1200 X 2100 | 1 |
| 2 | DOOR | 1000 X 2100 | 1 |
| 3 | DOOR | 900 X 2100 | 1 |
| 4 | DOOR | 750 X 2100 | 1 |
| 5 | DOOR | 1500 X 2100 | 1 |
| 6 | DOOR | 1200 X 2100 | 1 |
| 7 | DOOR | 900 X 2100 | 1 |
| 8 | DOOR | 750 X 2100 | 1 |
| 9 | DOOR | 600 X 2100 | 1 |

ALL DIM. ARE IN M. & MM SCALE 1:100, 1:50, 1:25, 1:200

STATEMENT OF AREA

TOTAL AREA OF LAND AS PER DEED	349.45 SQ.MT.
TOTAL PLOT AREA	349.45 SQ.MT.
ROAD WIDENING AREA	7.83 SQ.MT.
GROUND FLOOR AREA	236.25 SQ.MT.
FIRST FLOOR AREA	236.25 SQ.MT.
SECOND FLOOR AREA	
TOTAL BUILTUP AREA =	472.5 SQ.MT.
F.A.R = 236.25/349.45 =	1.35 SQ.MT.
GROUND COVERAGE% =	69.15%
	251.3/341.62

STRUCTURAL STABILITY CERTIFICATE
 THIS IS TO CERTIFY THAT SEISMIC LOADS HAVE BEEN TAKEN UNDER CONSIDERATION WHILE DESIGNING THE STRUCTURE OF THIS BUILDING.
 THE DESIGN HAS BEEN DONE AS PER IS 1893/1994 & IS 4326/1993.

SCALE	DRG. NO	
1:100	1	

SIGNATURE OF ARCHITECT
 SIGNATURE OF OWNER
 PROPOSED RESIDENTIAL BUILDING FOR (1) SMT, LALAWATI DEVI W/O LATE. AWARHAR LAL R.S. PLOT NO-2-1882 KHATA-274 VILLAGE-LOHARDAGA, THANA-194 THANA NO.-LOHARDAGA, DISTRICT-LOHARDAGA, (BARKHARD)

REVISIONS

NO.	REVISION	DATE
1	ISSUED FOR PERMIT	10/11/2024

COLOR INDEX

PARALLEL CALCULATION

Sl. No.	Description	Rate	Quantity	Amount
1

DOOR / WINDOW SCHEDULE

Sl. No.	Description	Qty
1	DOOR	1

STATEMENT OF AREA

Sl. No.	Description	Area (Sq. M)
1

STRUCTURAL STABILITY CERTIFICATE
 THIS IS TO CERTIFY THAT SEISMIC LOADS HAVE BEEN TAKEN UNDER CONSIDERATION WHILE DESIGNING THE STRUCTURE OF THIS BUILDING.
 THE DESIGN HAS BEEN DONE AS PER IS 1893/1994 & IS 4326/1993.

SCALE	DRG. NO	
1:100	1	

SIGNATURE OF ARCHITECT
 SIGNATURE OF OWNER
 PROPOSED RESIDENTIAL BUILDING FOR (1) SMT, LALAWATI DEVI W/O LATE. AWARHAR LAL R.S. PLOT NO-2-1882 KHATA-274 VILLAGE-LOHARDAGA, THANA-194 THANA NO.-LOHARDAGA, DISTRICT-LOHARDAGA, (BARKHARD)