

# Project Title :SANGITA DEVI

PROJECT STATEMENT	LOWWAGA NAGAR PARISHAD	VERSION NO. 1.0.19
PROJECT DETAIL:	Plot Use - Residential	VERSION DATE: 01/01/2019
Region -	Andhra Pradesh	
Local Body -	Lowwaga Nagar Parishad	
Plot Size -	10.00 Sq. Mts	
Application Type -	General Proposal	
Project Type -	Building Permission	
Nature of Development -	New	
Location -	Old Area	
Plot Location -	Plot No. 10	
Village/Mouza Name -	Lowwaga	
Ward No. -	North	
Road Name -	South	
Phase -	East	
Other -	West	

AREA DETAILS:		50.00
AREA OF PLOT (Minimum)	(A)	162.75
Net Plot Area (Gross Plot Area - Deduction from Gross Plot Area)	(A-Deductions)	162.75
Deductions for Balance Plot Area from Gross Plot Area		23.58
Net Plot Area		23.58
Balance Plot Area (Net Plot Area - Proposed/Existing Area)	(A-Deductions)	139.17
Plot Area for Coverage (Net Plot Area)	(A-Deductions)	162.75
Plot Area for 75% Net Plot Area + Road/Watering Area	(A-Deductions)	162.75
Minimum Area		0.82
COVERAGE CHECK		
Proposed Coverage Area (47.77%)		77.75
Min. Coverage Area (27.77%)		45.75
FAR CHECK		
Proposed Area of FAR		233.25
Min. Area of FAR		233.25
BUILT UP AREA CHECK		
Total Proposed Builtup Area		233.25
ARCHITECT / SUPERVISOR (Stamp)	OWNER	
DEVELOPMENT AUTHORITY	LOCAL BODY	

COLOR INDEX			
ABUTTING ROAD			
PROPOSED WORK (COVERAGE AREA)			
EXISTING (To be retained)			
EXISTING (To be demolished)			
Color Index:			
Parking Type	Prop No.	Prop Area	
Other Parking	1	30.44	
Total Area			30.44

Building / Wing Name	Road Name	Front Margin	Rear Margin	Side1 Margin	Side2 Margin
A (SANGITA DEVI)	8 METER WIDE ROAD Access	3.03	3.97	0.00	0.91

Building	No. of Same Bldg	Total Built Up Area (Sq.m)	Proposed FAR Area (Sq.m)	Total FAR Area (Sq.m)	Terr (No.)
A (SANGITA DEVI)	1	233.25	233.25	233.25	01
Grand Total	1	233.25	233.25	233.25	01

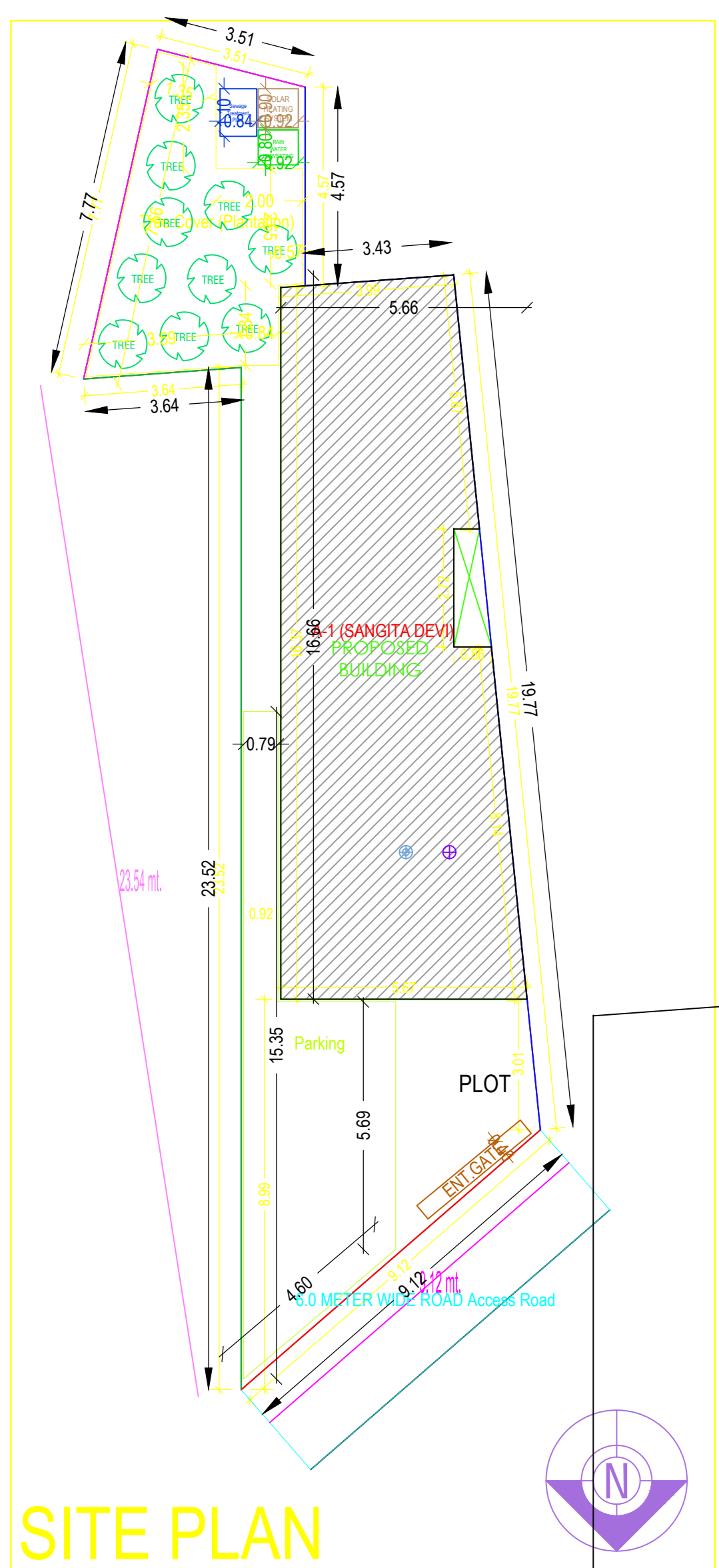

SITE PLAN

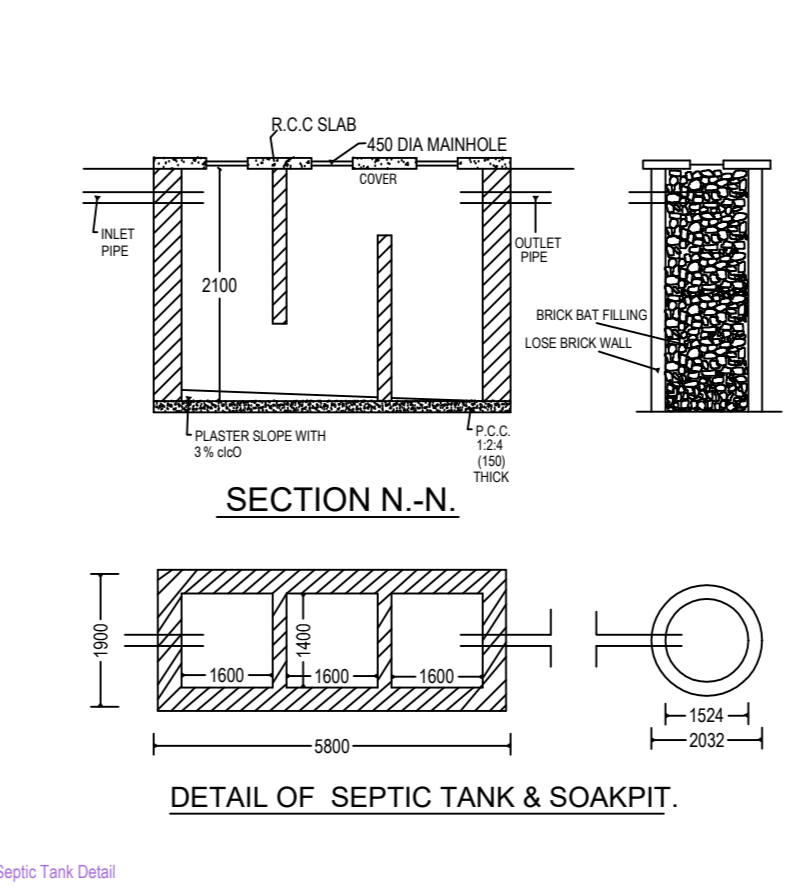
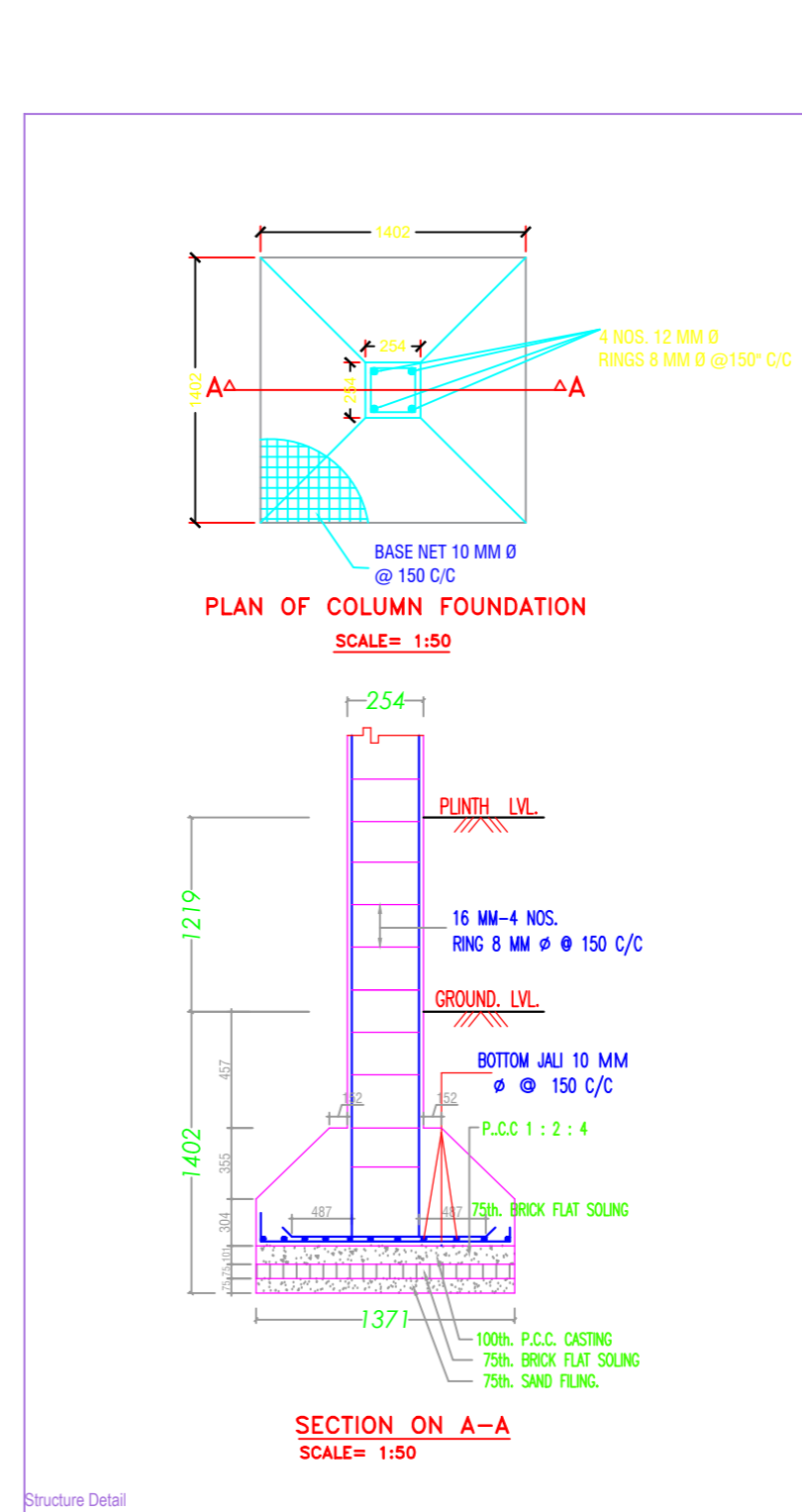
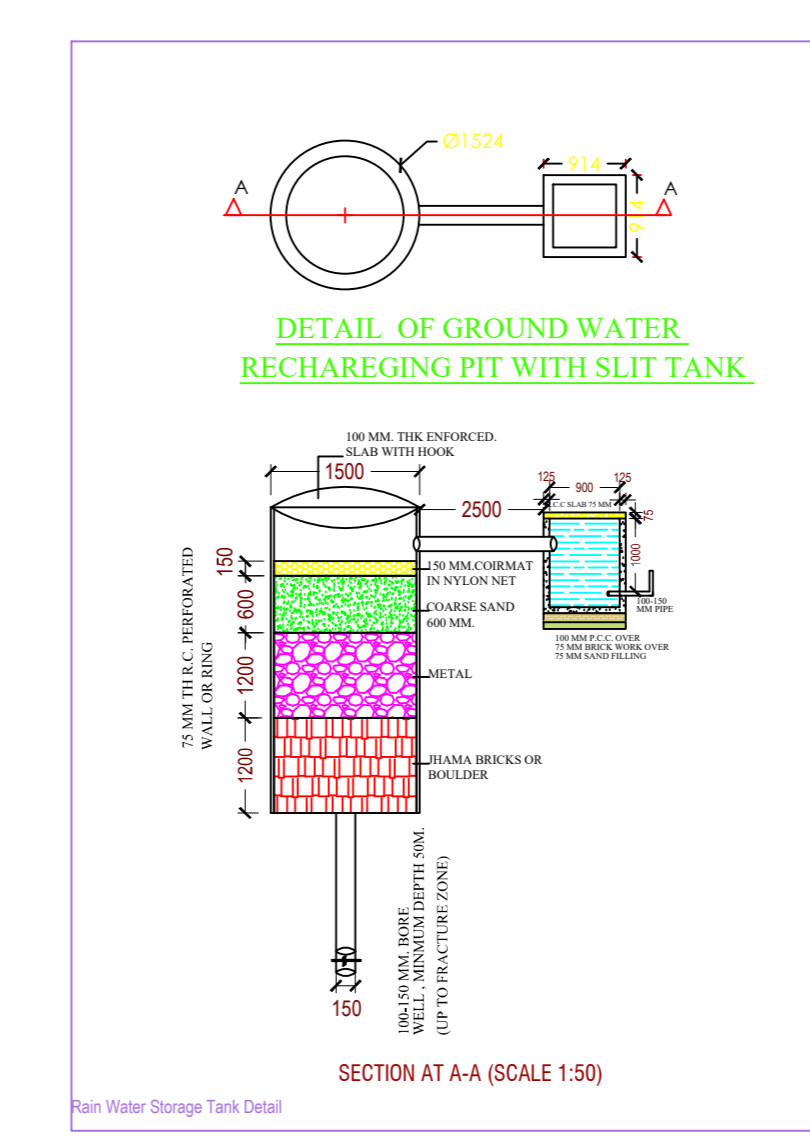
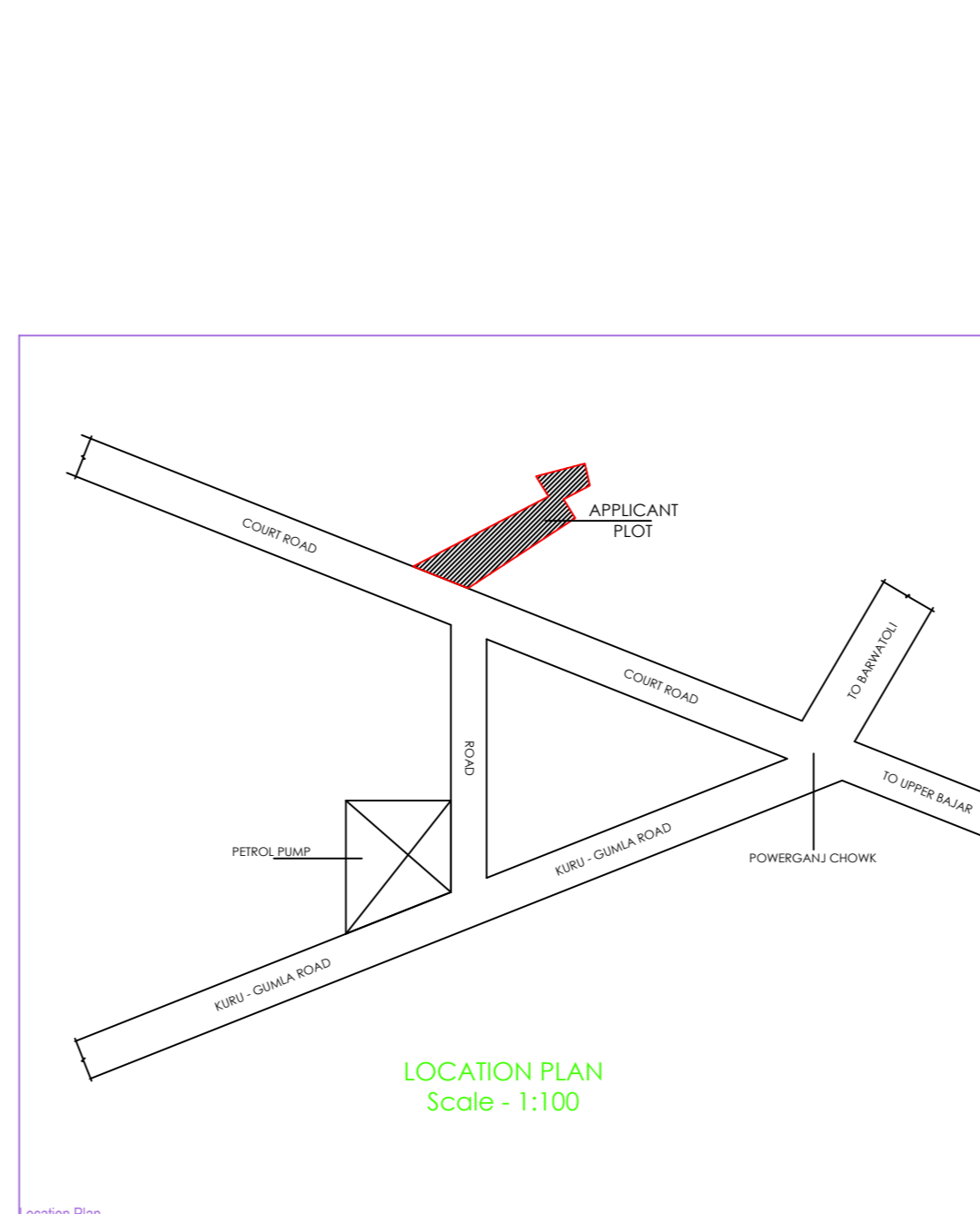
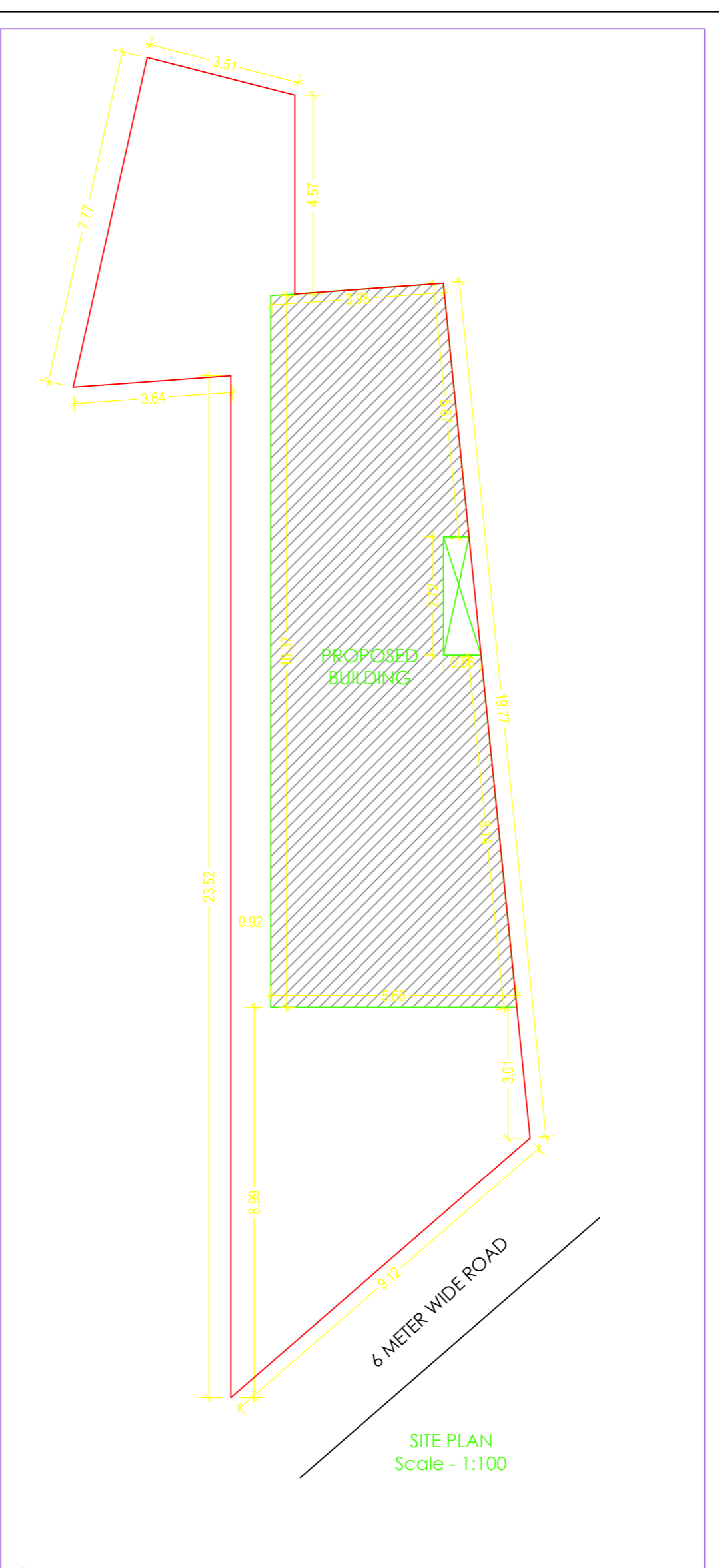
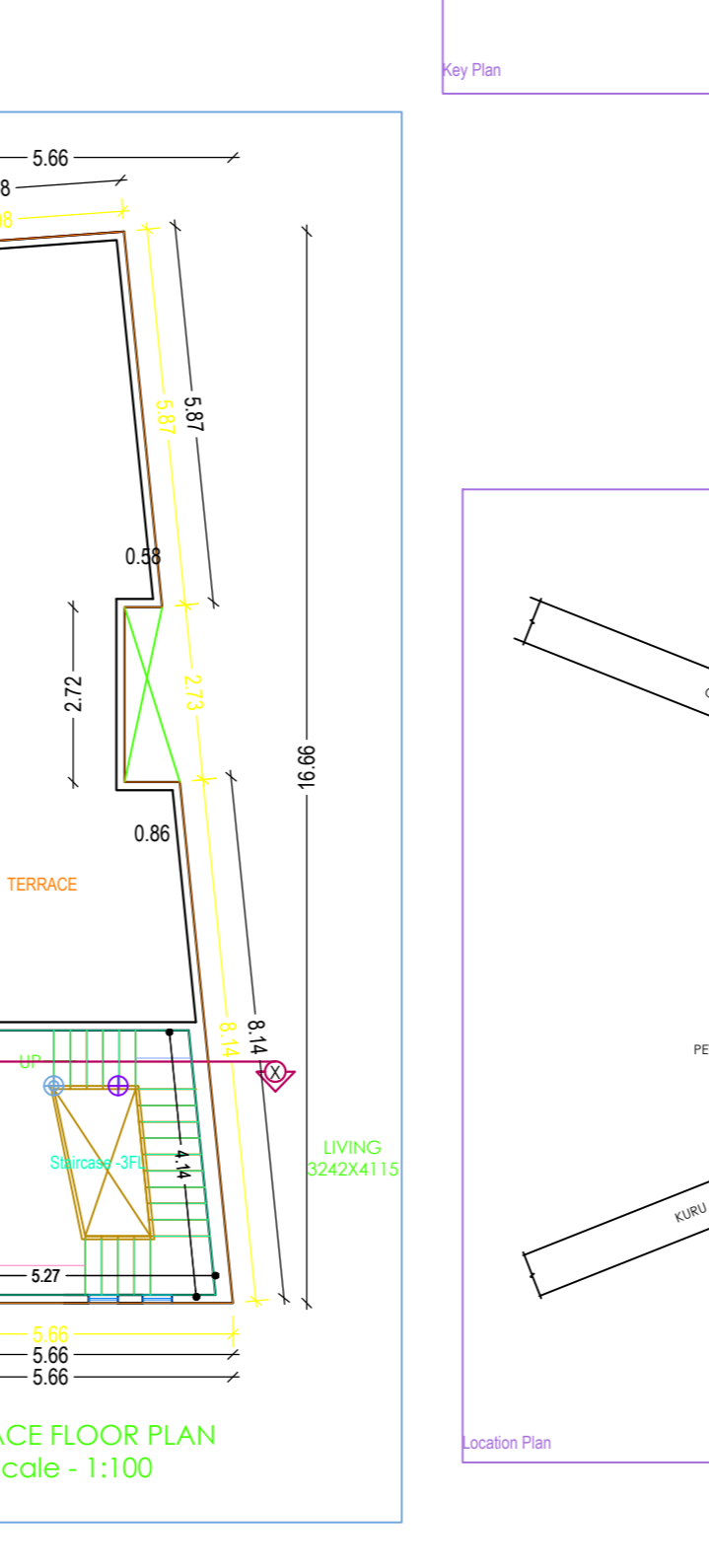
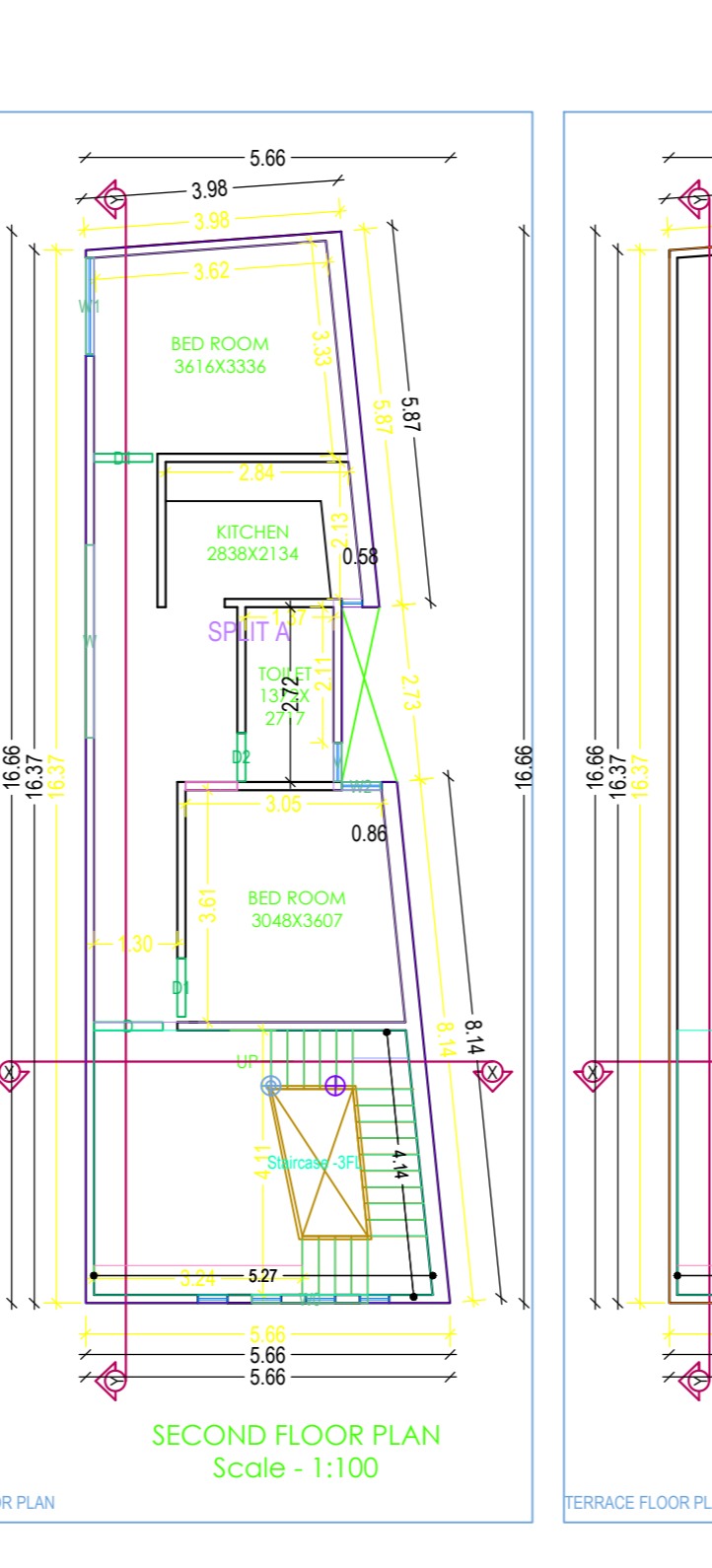
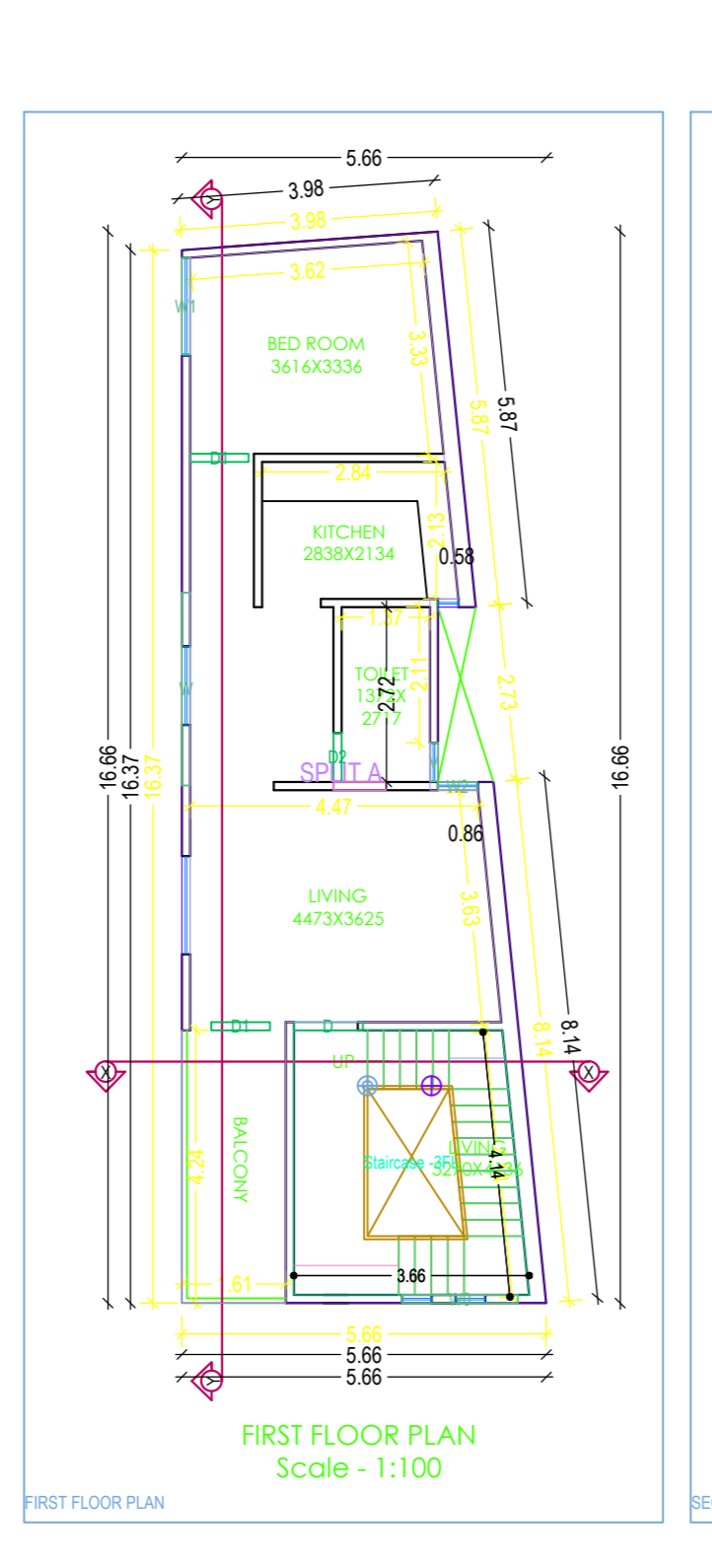
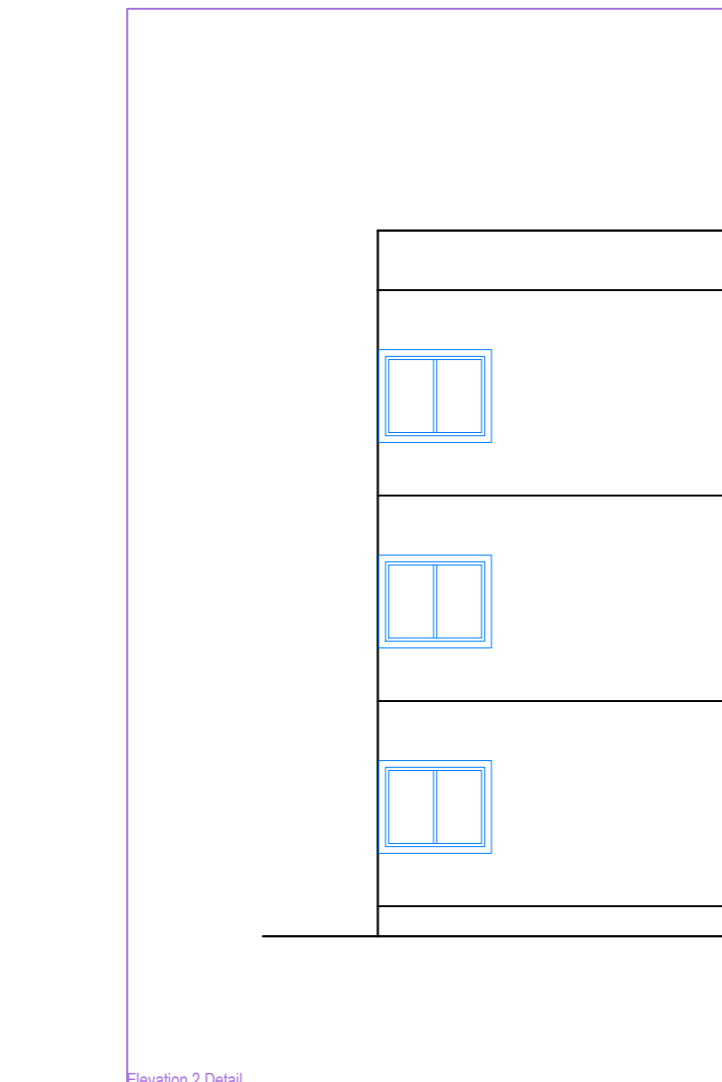
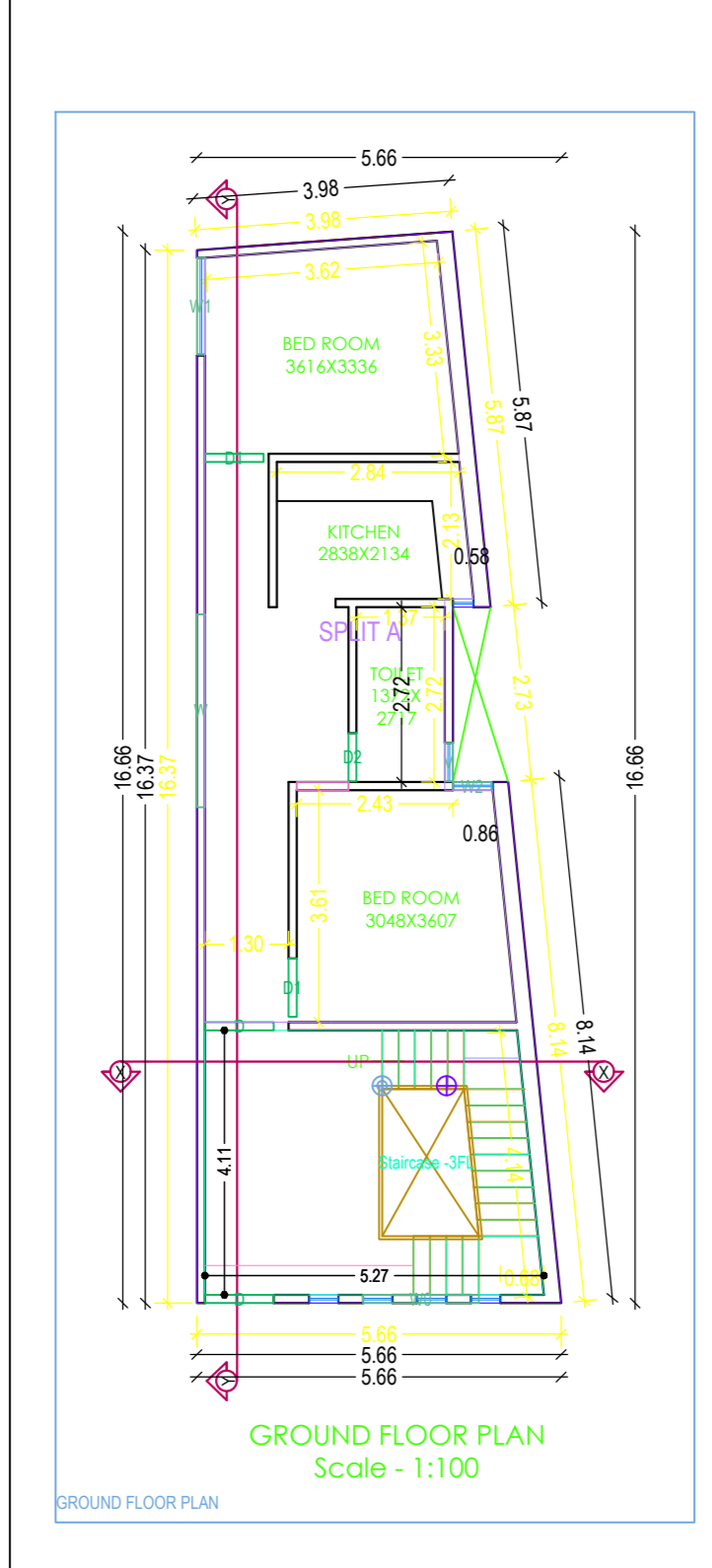
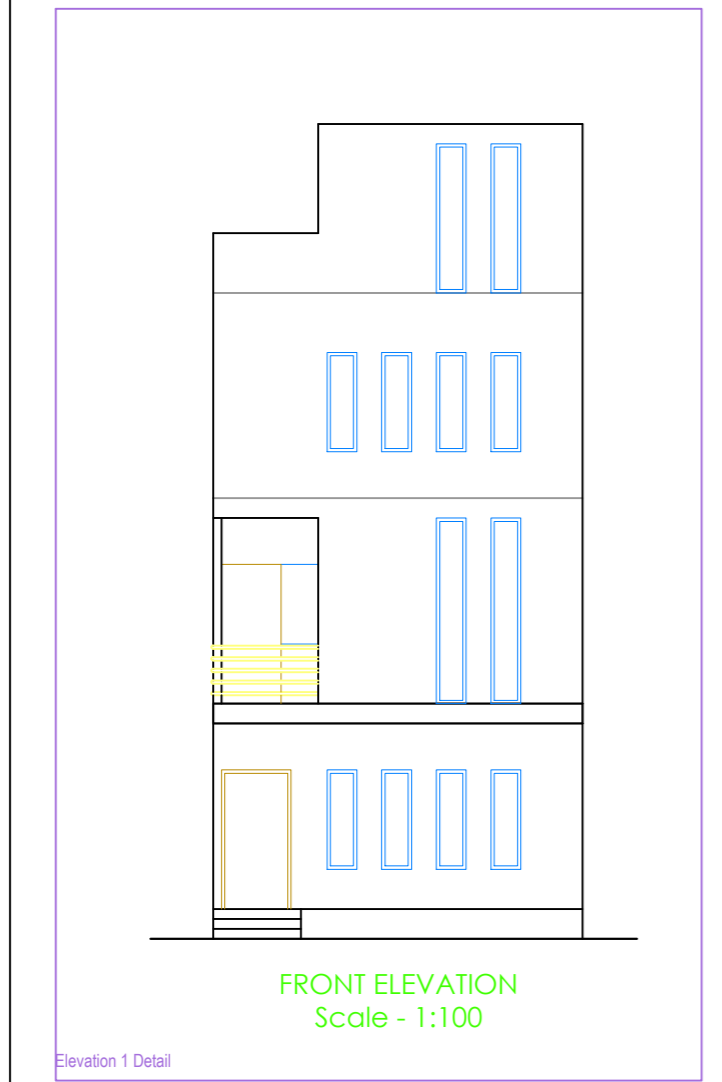
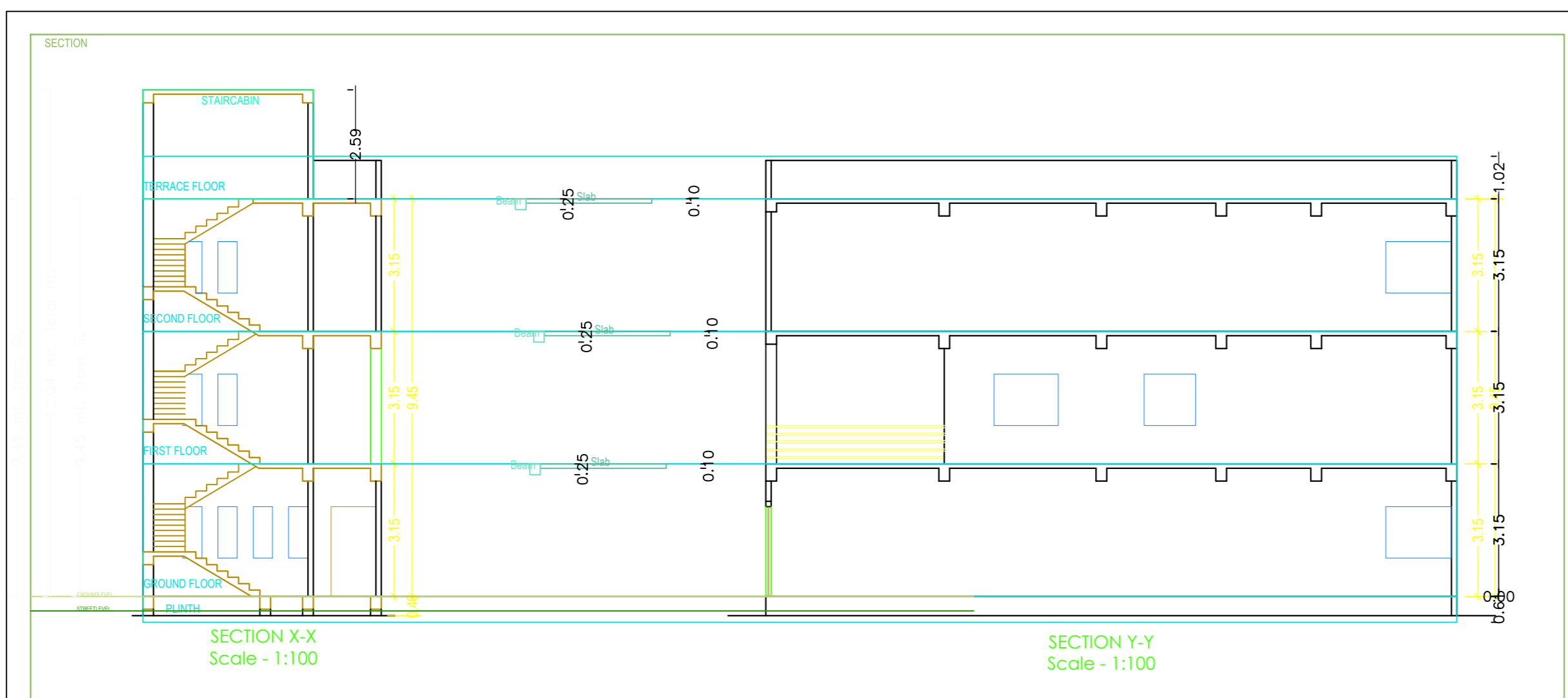

Building A (SANGITA DEVI)

Floor Name	Total Built Up Area (Sq.m)	Proposed FAR Area (Sq.m)	Total FAR Area (Sq.m)	Terr (No.)
Ground Floor	77.75	77.75	77.75	01
First Floor	77.75	77.75	77.75	00
Second Floor	77.75	77.75	77.75	00
Terrace Floor	0.00	0.00	0.00	00
Total	233.25	233.25	233.25	01
Total Number of Same Buildings	1			
Total	233.25	233.25	233.25	01

SCHEDULE OF JOINERY:

BUILDING NAME	NAME	LENGTH	HEIGHT	NOS
A (SANGITA DEVI)	CP	0.75	2.13	03
A (SANGITA DEVI)	CH	0.91	2.13	06
A (SANGITA DEVI)	CI	1.07	2.13	04
Total				13

SCHEDULE OF JOINERY:

BUILDING NAME	NAME	LENGTH	HEIGHT	NOS
A (SANGITA DEVI)	V	0.60	1.60	03
A (SANGITA DEVI)	WS	1.60	2.70	03
A (SANGITA DEVI)	WI	1.50	2.70	03
A (SANGITA DEVI)	WS	1.80	2.70	03
A (SANGITA DEVI)	WI	1.90	2.70	03
Total				15

Unit/BUA Table for Building A (SANGITA DEVI)

FLOOR	SPACING	Name	Unit/BUA Type	Unit/BUA Area	Carpet Area	No. of Rooms	No. of Tenement
FLOOR PLAN	SPLIT A	FLAT	FLAT	154.21	153.96	4	1
Total				154.21	153.96	02	1