

Project Title :IMTEYAJ ALAM

AREA STATEMENT: LOHARDAGA NAGAR PARISHAD	VERSION NO: 1.0.21
PROJECT DETAIL:	VERSION DATE: 01/01/2019
Inward No. :-	PLOT USE - Residential
Region :- JHARKHAND URBAN LOCAL BODIES	Plot SubUse - Bungalow/ Dwelling / Non Apartment
District :- LOHARDAGA	Land Use Zone - NA
Application Type :- General Proposal	Abutting Road Width :-
Project Type :- Building Permission	PLOT No. :-
Nature of Development :- New	Revenue Survey No./Survey No. :-
Location :- Old Area	Thana No. :-
Sub Location :- NA	Holding No. :-
Village/Mouza Name :-	Khasra No. :-
Ward No. :-	North :-
Road/Street :-	South :-
	East :-
	West :-

AREA DETAILS:		SQ.MT.
AREA OF PLOT (Minimum)	(A)	161.36
Net Plot Area (Gross Plot Area - Deductions from Gross Plot Area)	(A-Deductions)	161.36
Deductions for Balance Plot Area (from Gross Plot Area)		18.05
COP Area		143.31
Total		161.36
Balance Plot Area (Net Plot Area - Recreation/Amenity space)	(A-Deductions)	143.31
Plot Area for Coverage (Net Plot Area)	(A-Deductions)	161.36
Plot Area for FSI (Net Plot Area - Road/Widening Area)	(A-Deductions)	161.36
Accessory Use Area		0.92
COVERAGE CHECK:		
Proposed Coverage Area (67.67 %)		109.19
Total Coverage Area (67.67 %)		109.19
FAR CHECK:		
Proposed Area of FAR		96.35
Total Area of FAR		96.35
BUILT UP AREA CHECK:		
Total Proposed Built Up Area		96.35
ARCHT ENGRS/SUPERVISOR (Regd)		OWNER
DEVELOPMENT AUTHORITY		LOCAL BODY

COLOR INDEX	
PLOT BOUNDARY	
ABUTTING ROAD	
PROPOSED WORK (COVERAGE AREA)	
EXISTING (To be retained)	
EXISTING (To be demolished)	

PARKING CALCULATION:			
Parking Type	Prop No.	Prop Area	
Other Parking	1	12.84	12.84
Total Area			

MARGIN DETAIL:					
Building / Wing Name	Road Name	Front Margin	Rear Margin	Side1 Margin	Side2 Margin
A-1 (IMTEYAJ ALAM)	3.60 MTR WIDE ROAD Access Road	2.80	1.50	0.00	0.90

FAR & Tenement Details (Table 4c-1)							
Building	No. of Same Bldg	Gross Built Up Area (Sq.mt.)	Deductions From Gross BU/Area in Sq.mt. Cutout	Total Built Up Area (Sq.mt.)	Proposed FAR Area (Sq.mt.)	Total FAR Area (Sq.mt.)	Tntmt (No.)
A (IMTEYAJ ALAM)	1	97.96	1.61	96.35	96.35	96.35	01
Grand Total:	1	97.96	1.61	96.35	96.35	96.35	01

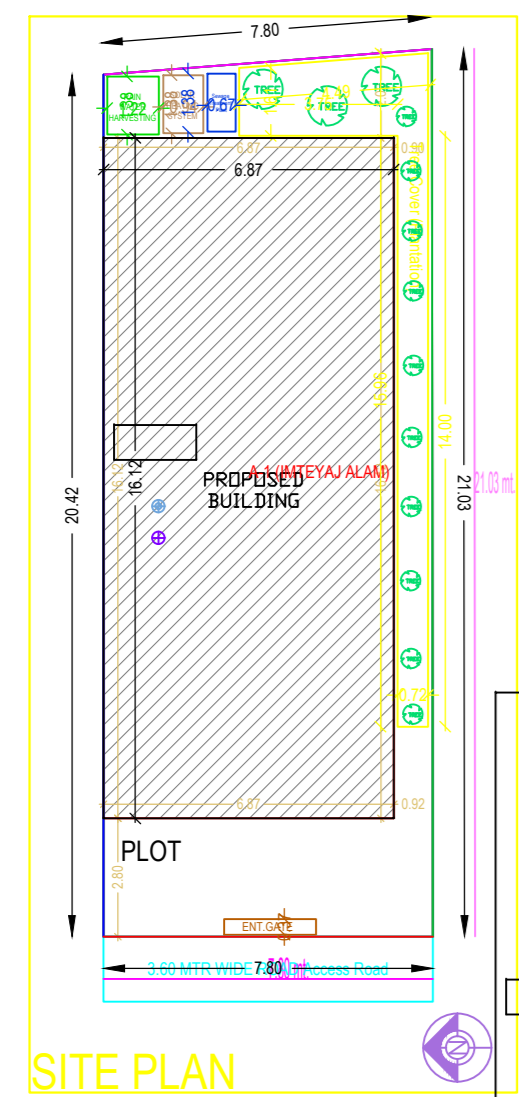
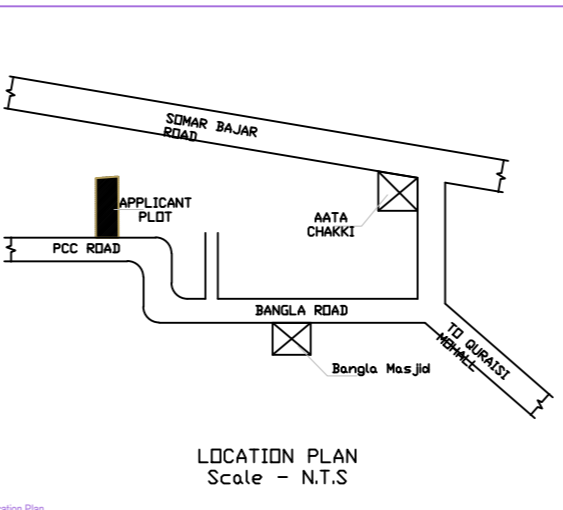
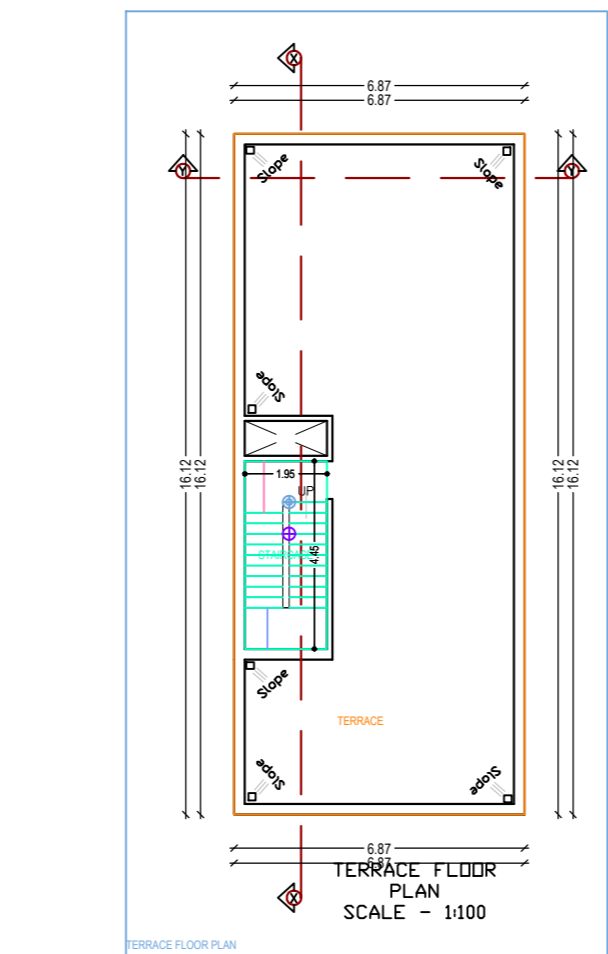
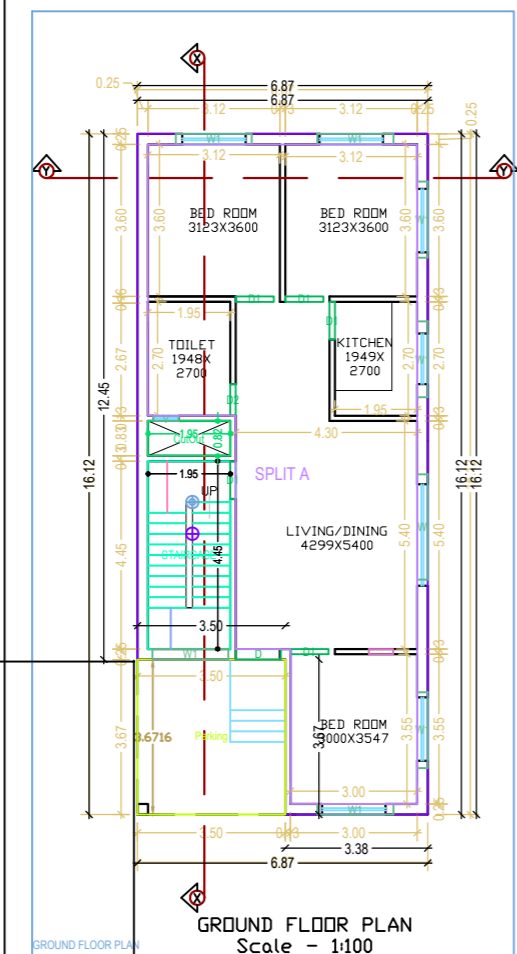
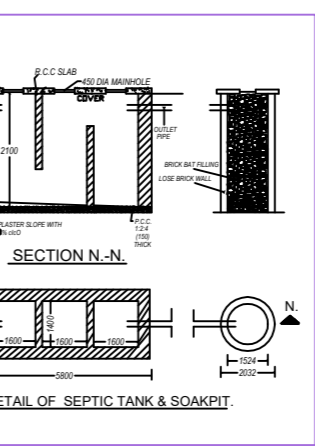
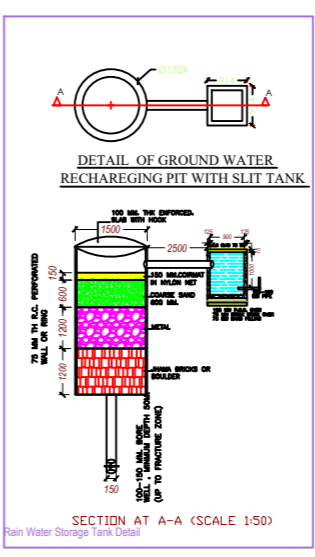
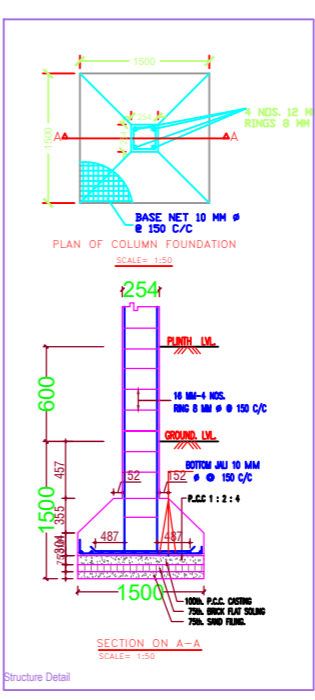
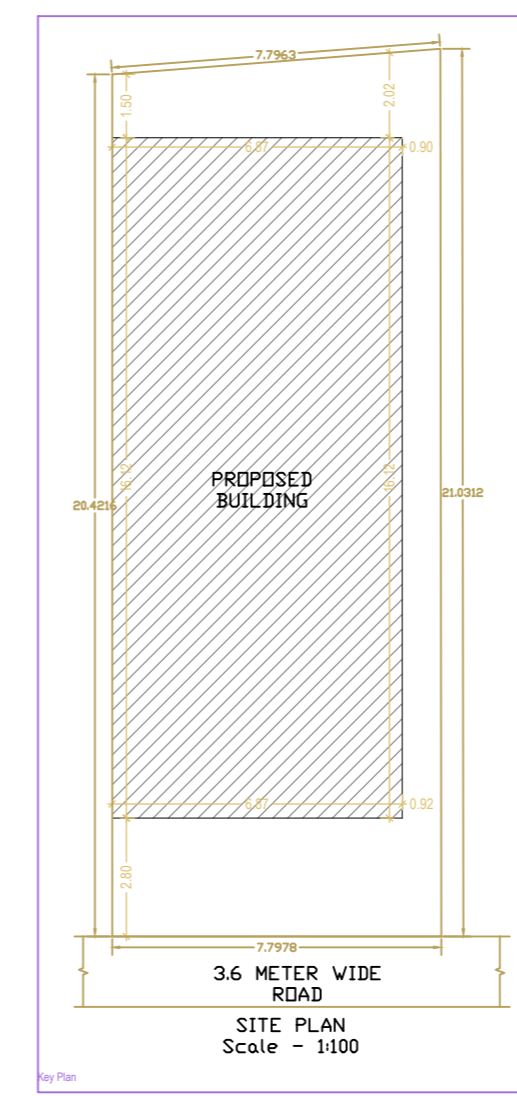
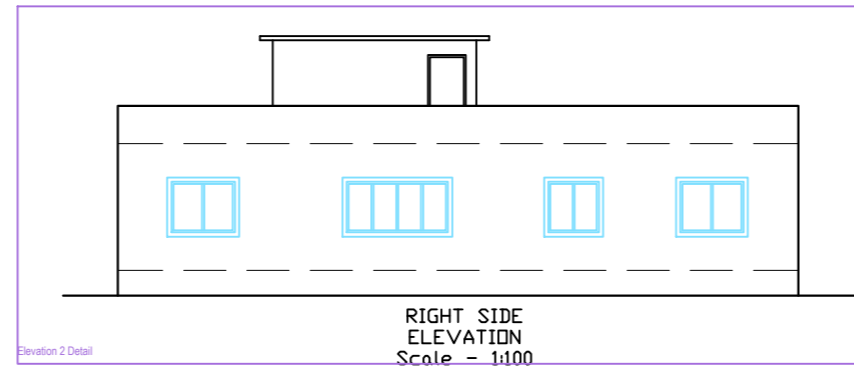
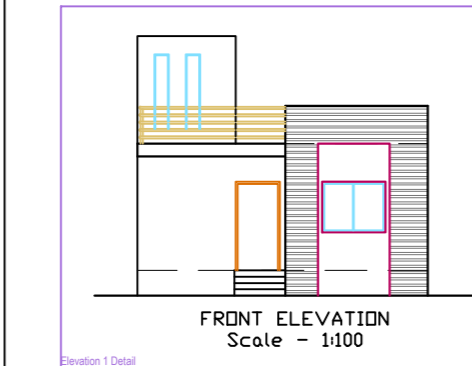
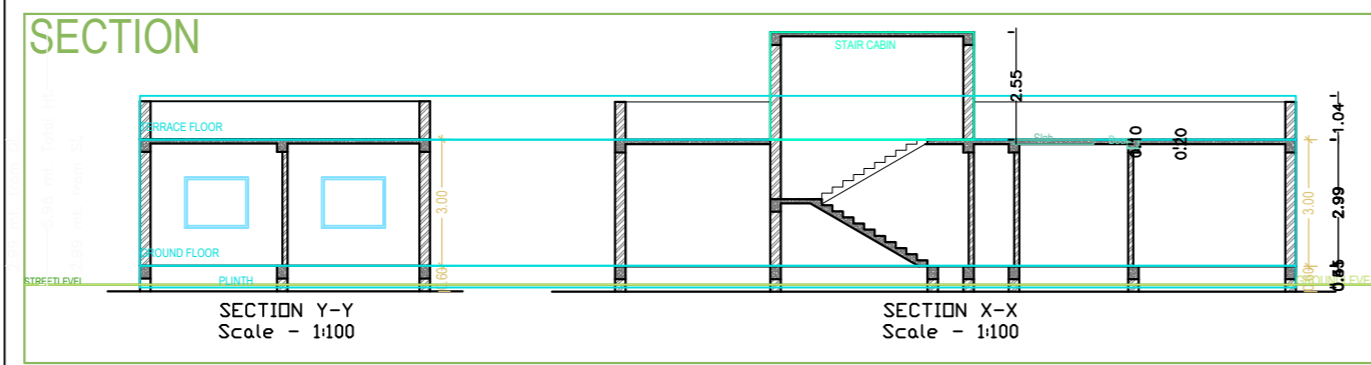

Building 'A' (IMTEYAJ ALAM)						
Floor Name	Gross Built Up Area	Deductions From Gross BU/Area in Sq.mt. Cutout	Total Built Up Area (Sq.mt.)	Proposed FAR Area (Sq.mt.)	Total FAR Area (Sq.mt.)	Tntmt (No.)
Ground Floor	97.96	1.61	96.35	96.35	96.35	01
Terrace Floor	0.00	0.00	0.00	0.00	0.00	00
Total	97.96	1.61	96.35	96.35	96.35	01
Total Number of Same Buildings	1					
Total	97.96	1.61	96.35	96.35	96.35	01

SCHEDULE OF JOINERY:				
BUILDING NAME	NAME	LENGTH	HEIGHT	NOS
A (IMTEYAJ ALAM)	D2	0.75	2.13	01
A (IMTEYAJ ALAM)	D1	0.90	2.13	05
A (IMTEYAJ ALAM)	D	1.07	2.13	01
Total	-	-	-	07

SCHEDULE OF JOINERY:				
BUILDING NAME	NAME	LENGTH	HEIGHT	NOS
A (IMTEYAJ ALAM)	Y	0.60	1.00	01
A (IMTEYAJ ALAM)	W1	1.80	2.70	07
A (IMTEYAJ ALAM)	W	2.50	2.70	01
Total	-	-	-	09

Unit/BUA Table for Building 'A' (IMTEYAJ ALAM)						
FLOOR	Name	Unit/BUA Type	Unit/BUA Area	Carpet Area	No. of Rooms	No. of Tenement
GROUND FLOOR PLAN	SPLIT A	FLAT	75.71	75.64	6	1
Total	-	-	75.71	75.64	6	1