

Project Title :SMT MUNNI DEVI

AREA ESTIMATION (CONCRETE WORK)		SECTION NO. 1-100	
Project Name	SMT MUNNI DEVI	Section No.	1-100
Project Location	...	Scale	1:100
Project Type	...	Area	...
Client Name	...	Volume	...
Design No.	...	Weight	...
Revision

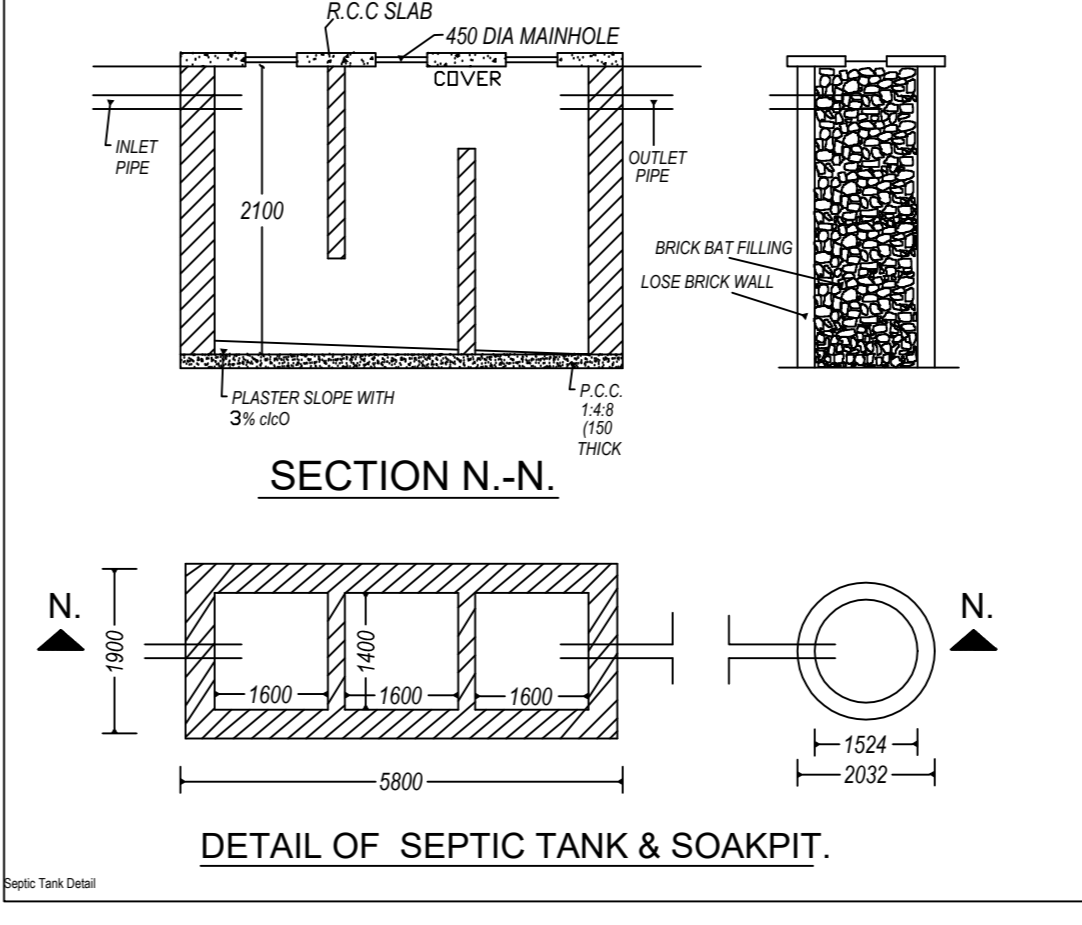
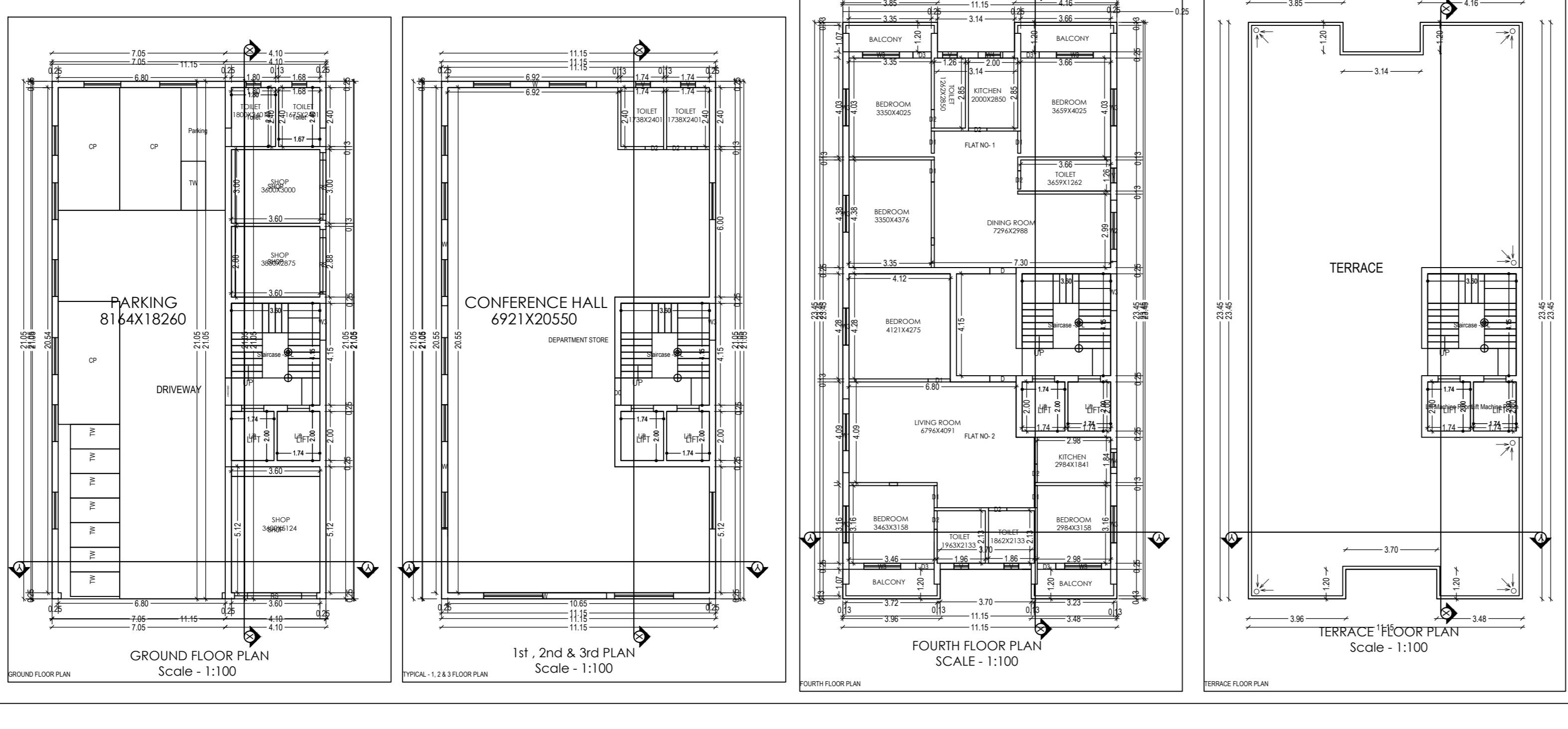
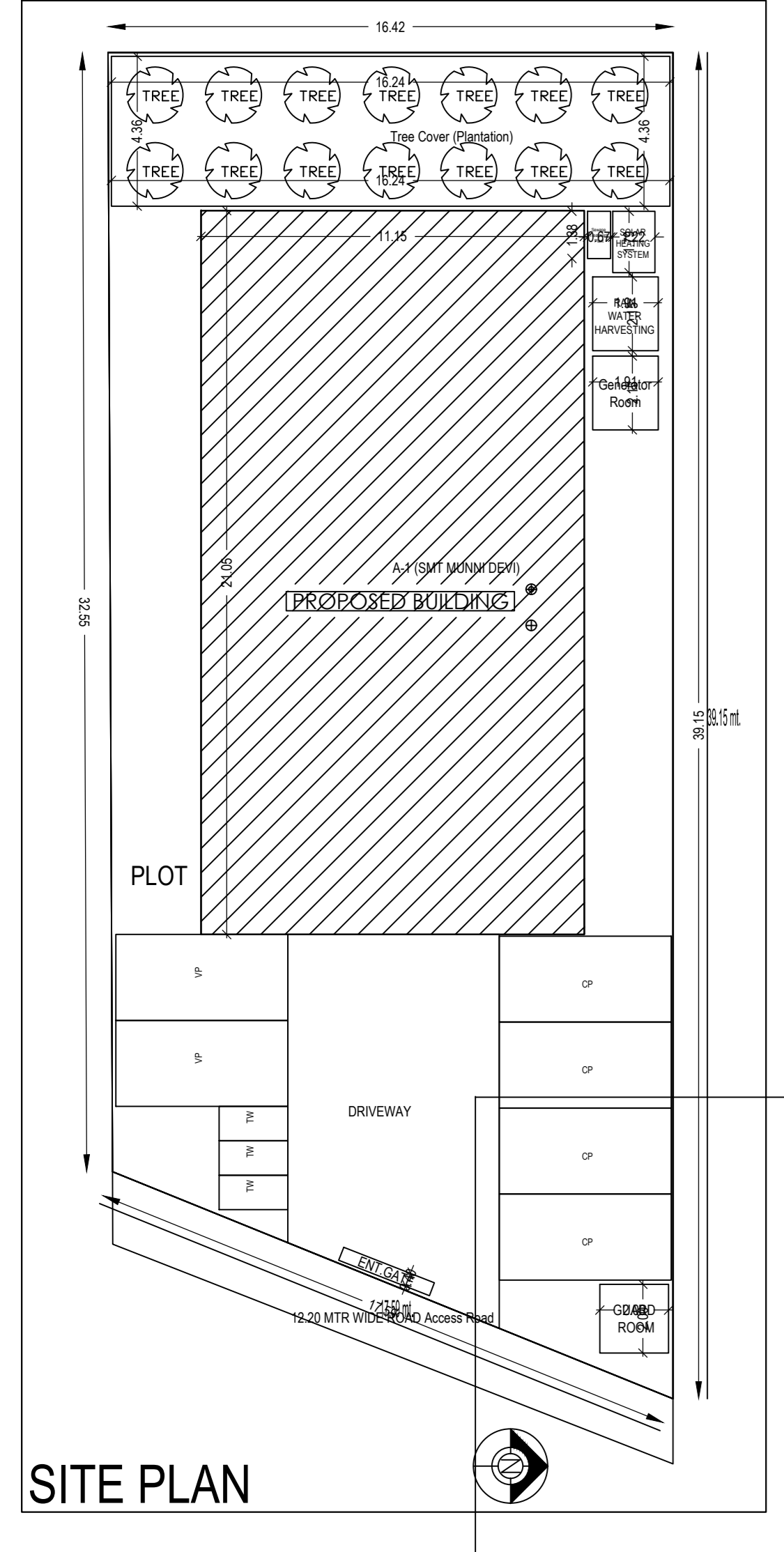
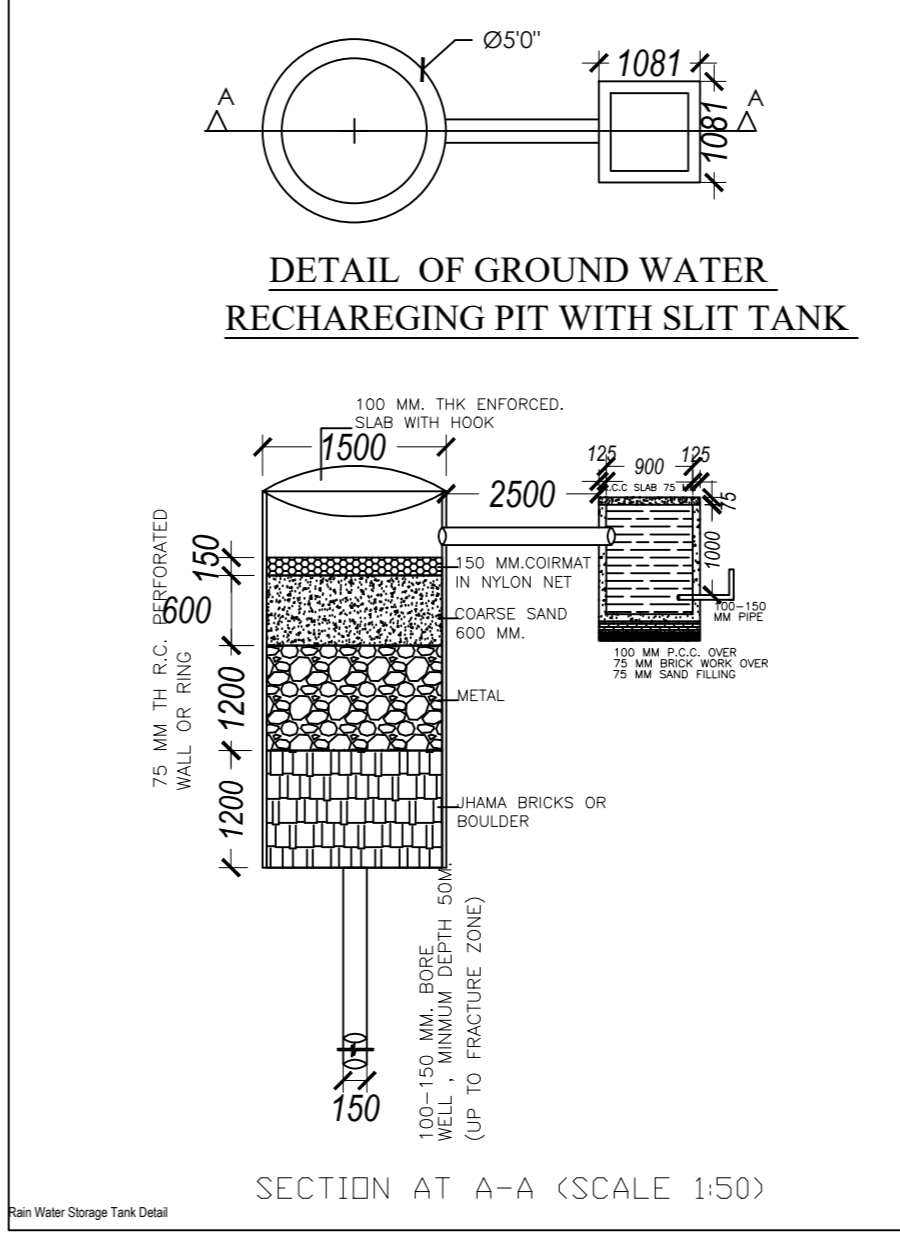
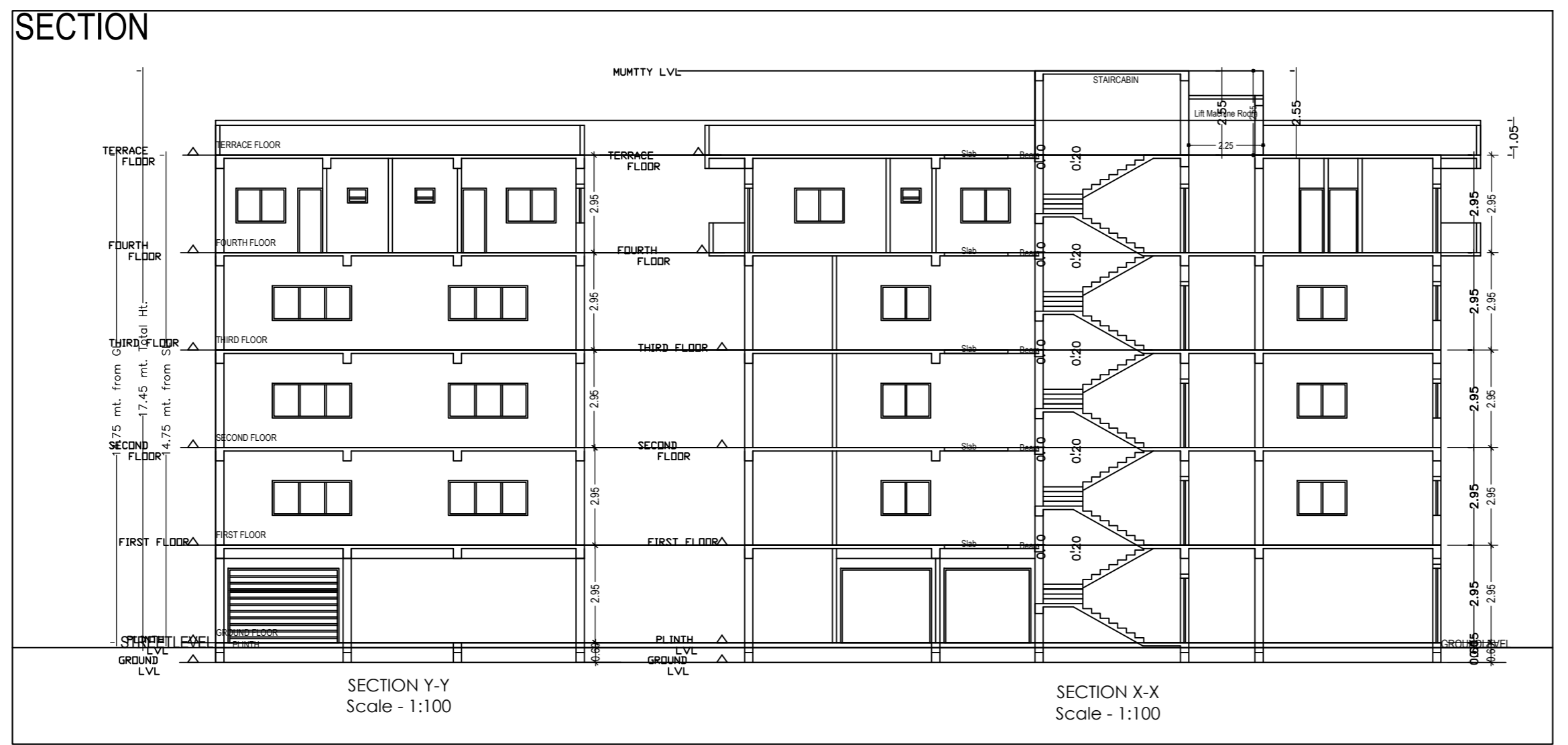
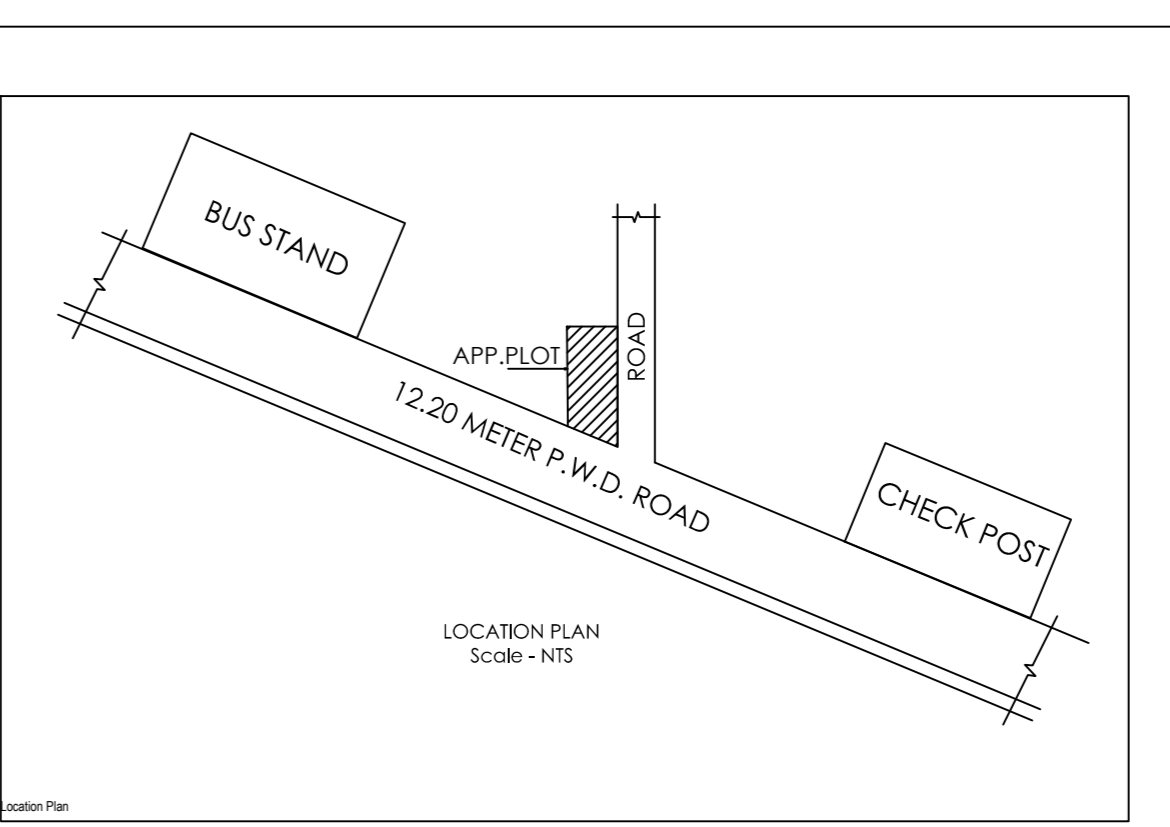
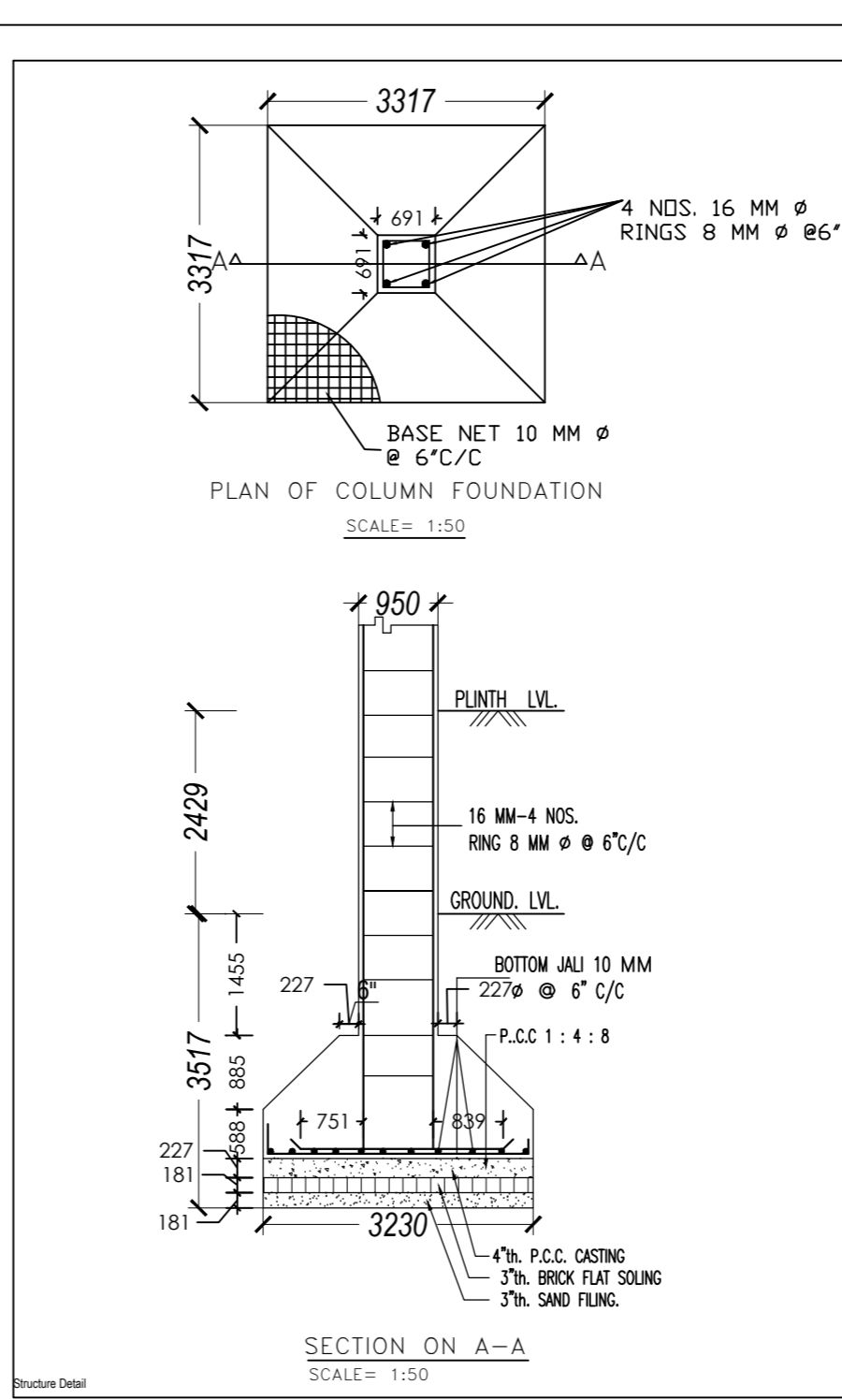
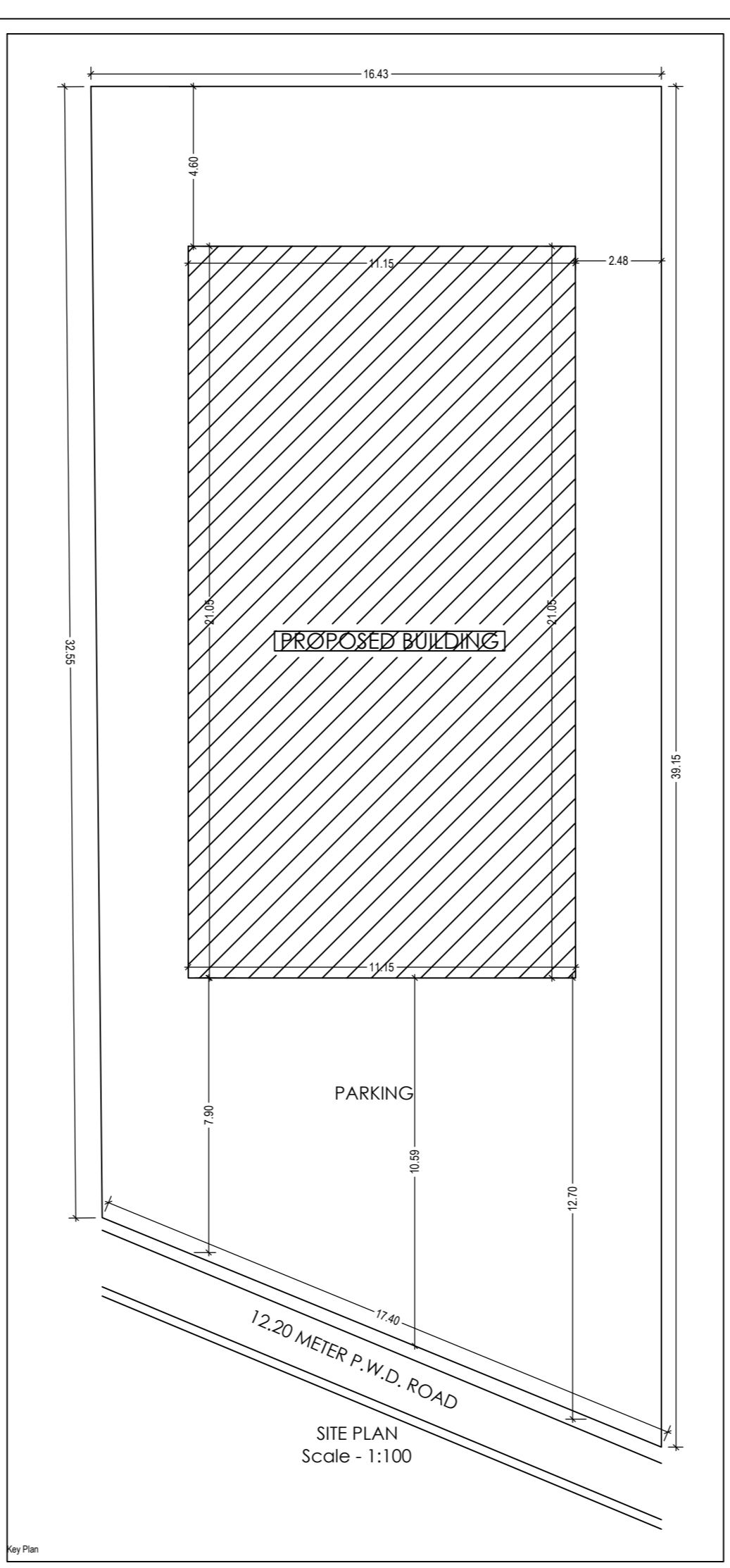

PARKING CALCULATION			
Plot Area	3317	Plot Area	3317
Area for Road & Drain	150	Area for Road & Drain	150
Area for Building	1500	Area for Building	1500
Area for Parking	1667	Area for Parking	1667
Area for Green Belt	150	Area for Green Belt	150
Area for Other	150	Area for Other	150
Total Area	3317	Total Area	3317

SITE PLAN A (SMT MUNNI DEVI)

Sl. No.	Item Name	Quantity	Unit	Rate	Amount	Remarks
1	Concrete	100	CU.M	100	10000	...
2	Reinforcement	200	TON	50	10000	...
3	Brick	5000	NO.	5	25000	...
4	Plaster	100	SQ.M	100	10000	...

Sl. No.	Item Name	Quantity	Unit	Rate	Amount
1	Door	10	NO.	100	1000
2	Window	20	NO.	50	1000
3	Shutter	5	NO.	200	1000

FLOOR	Area	Volume	Weight	Notes
GROUND FLOOR	1500	1500	1500	...
1st FLOOR	1500	1500	1500	...
2nd FLOOR	1500	1500	1500	...