

Project Title : FIRDOSH IMAM AND SADIQUE IMAM AND SAHID HASSAN AND KHALID IMAM

AREA STATEMENT : LOHARDAGA NAGAR PARISHAD		VERSION NO. : 1.0.26
PROJECT DETAIL :		VERSION DATE : 16/10/2020
Inward No. :	Plot Use : Residential	
Region : JHARKHAND URBAN LOCAL BODIES	Plot SubUse : Bungalow Dwelling / Non Apartment	
District : LOHARDAGA	Land Use Zone : 'NA'	
Application Type : General Proposal	Accounting Head (WH) : -	
Project Type : Building Permission	Plot No. :	
Nature of Development : New	Revenue Survey No/Survey No. :	
Location : Old Area	Thana No. :	
Sub Location : NA	Holding No. :	
Village/Moza Name : -	Khata No. :	
Ward No. :	North :	
Road/Street : -	South :	
	East :	
	West :	

AREA DETAILS :		UNIT	VALUE
AREA OF PLOT (Minimum)	(A)	SQ.MT	163.03
Net Plot Area (Gross Plot Area - Deduction from Gross Plot area)	(A-Deductions)		163.03
Deductions for Balance Plot Area (from Gross Plot Area)			
Total			21.32
Balance Plot Area (Net Plot Area - Recreational/Amenity spaces)	(A-Deductions)		141.71
Plot Area for Coverage (Net Plot Area)	(A-Deductions)		163.03
Plot Area for FSI (Net Plot Area + Road/Widening Area)	(A-Deductions)		163.03
Necessity/Work Area			0.96
COVERAGE CHECK			
Proposed Coverage Area (ET.50 %)			109.23
Total Coverage Area (ET.50 %)			109.23
FAR CHECK			
Proposed Area of FAR			327.69
Total Area of FAR			327.69
BUILD UP AREA CHECK			
Total Proposed BuiltUp Area			327.69
ARCHITECT SUPERVISOR (Regd)	OWNER		
DEVELOPMENT AUTHORITY	LOCAL BODY		

COLOR INDEX					
PLOT BOUNDARY					
ABUTTING ROAD					
PROPOSED WORK (COVERAGE AREA)					
EXISTING (To be retained)					
EXISTING (To be demolished)					

PARKING CALCULATION:			
Parking Type	Prop No.	Prop Area	
Other Parking	1	13.60	
<b>Total Area</b>			<b>13.60</b>

MARGIN DETAIL:					
Building / Wing Name	Road Name	Front Margin	Rear Margin	Side1 Margin	Side2 Margin
A ( FIRDOSH IMAM AND SADIQUE IMAM AND SAHID HASSAN AND KHALID IMAM)	9.75 MTR WIDE MAIN ROAD Access Road	2.58	1.63	0.00	1.11

FAR & Tenement Details (Table 4c-1)					
Building	No. of Same Bldg	Total Built Up Area (Sq.mt.)	Proposed FAR Area (Sq.mt.)	Total FAR Area (Sq.mt.)	Tent (No.)
A ( FIRDOSH IMAM AND SADIQUE IMAM AND SAHID HASSAN AND KHALID IMAM)	1	327.69	327.69	327.69	01
<b>Grand Total</b>	<b>1</b>	<b>327.69</b>	<b>327.69</b>	<b>327.69</b>	<b>01</b>

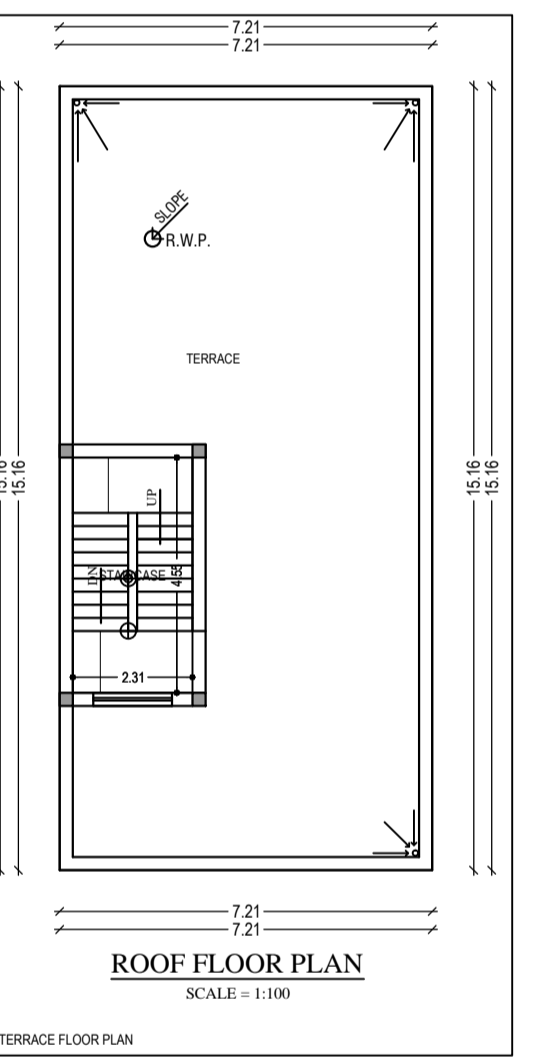
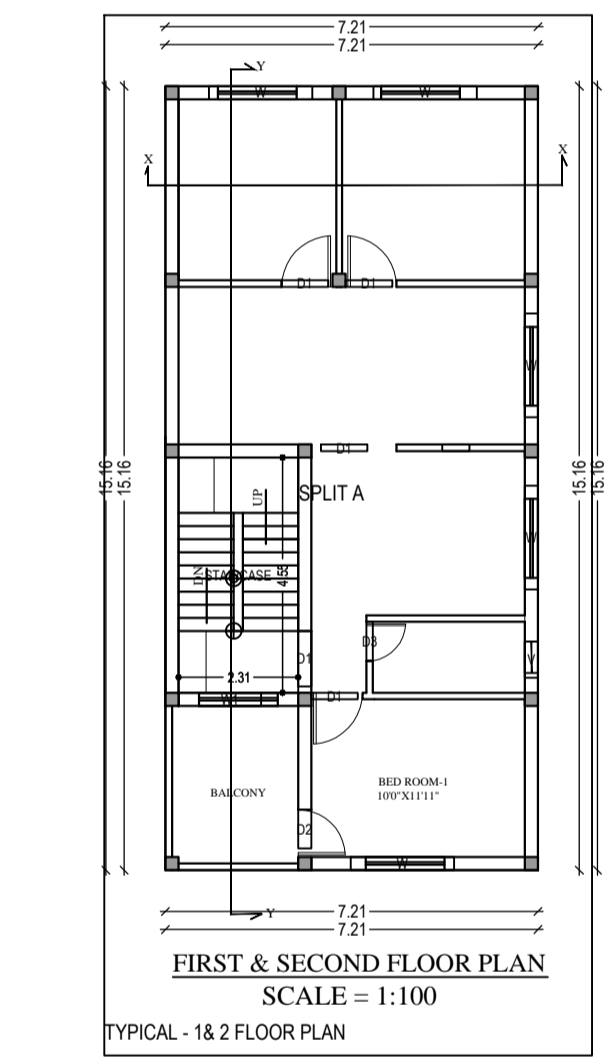
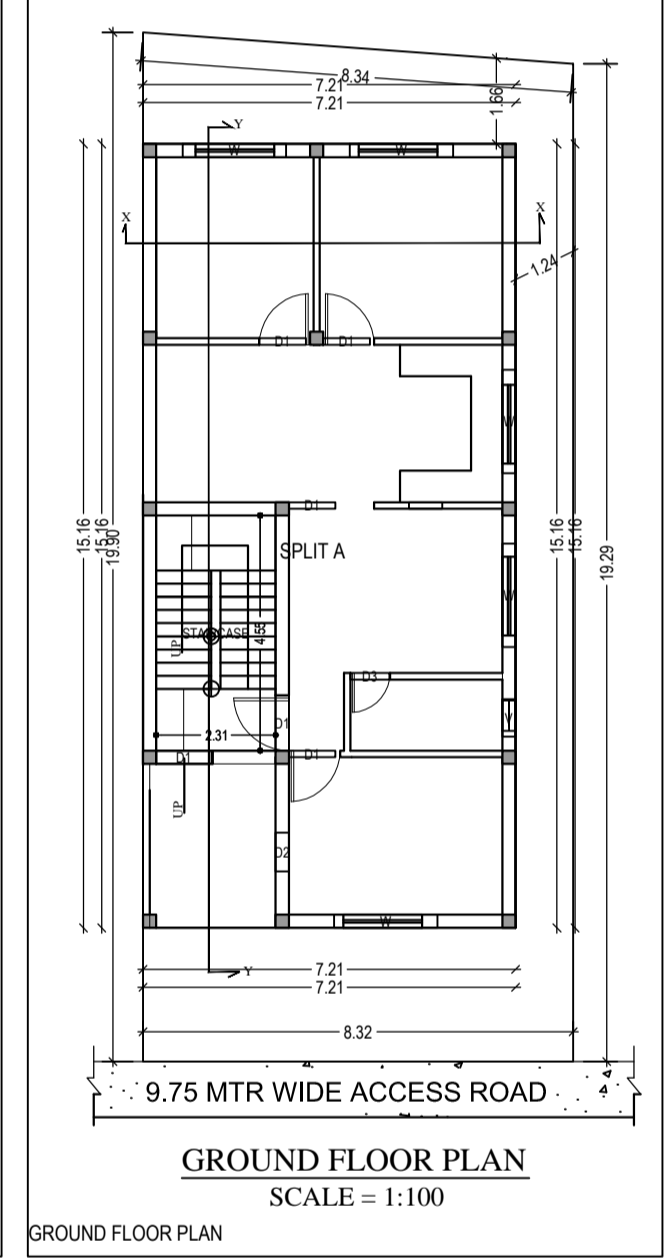
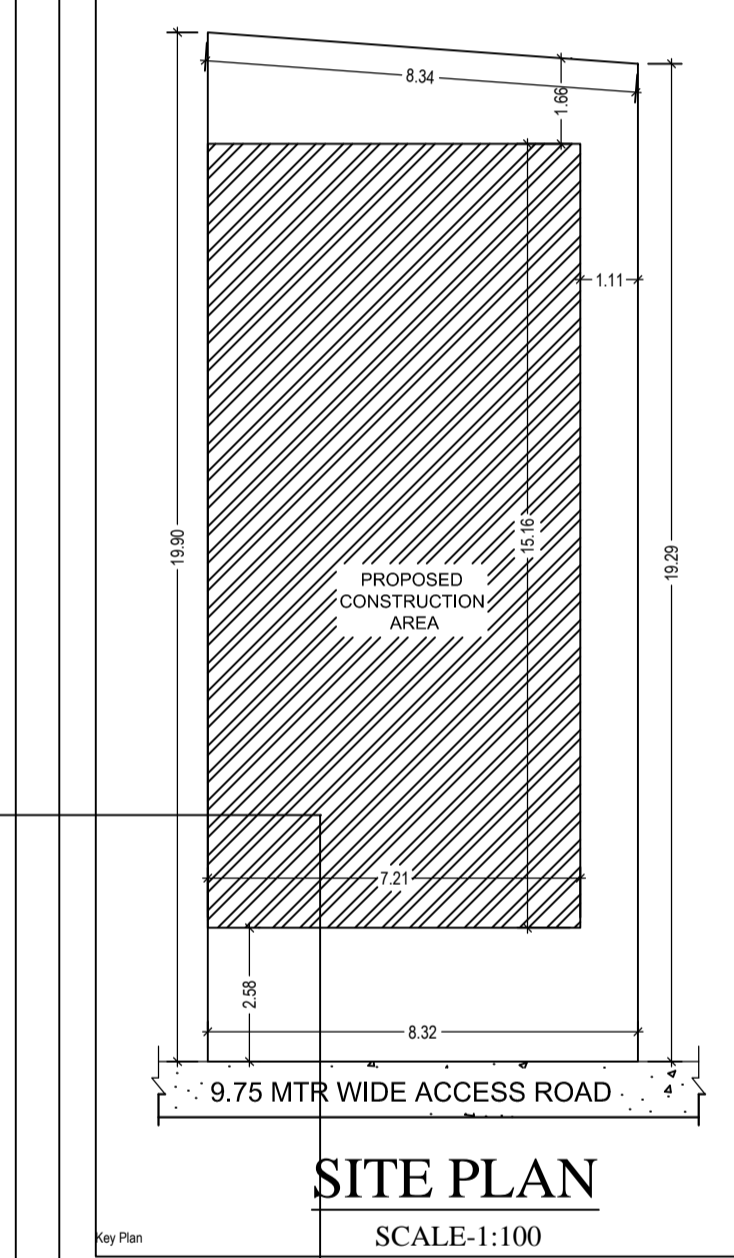
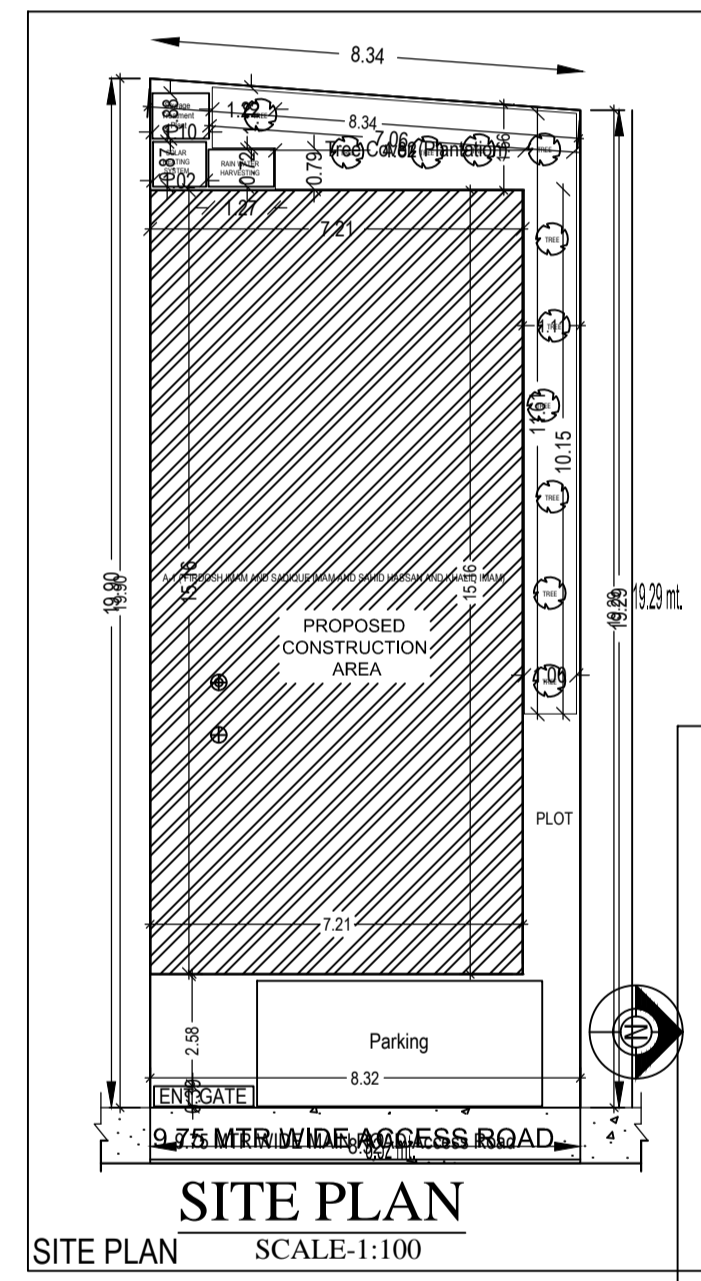
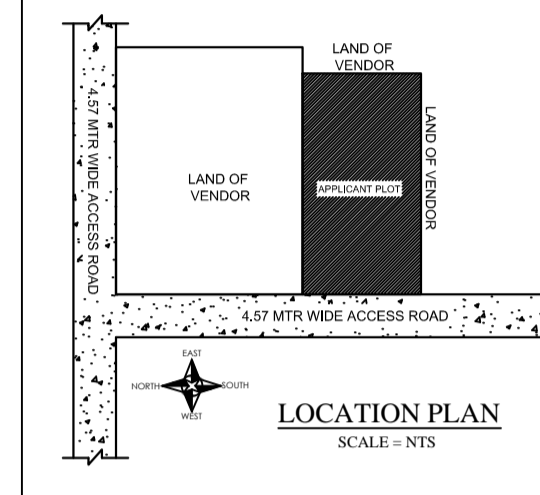
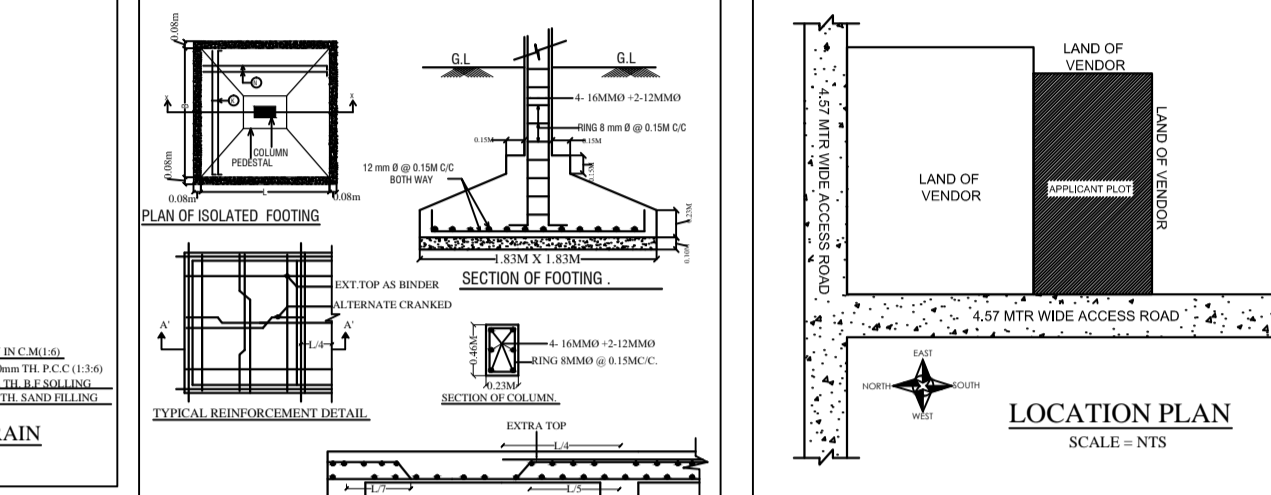
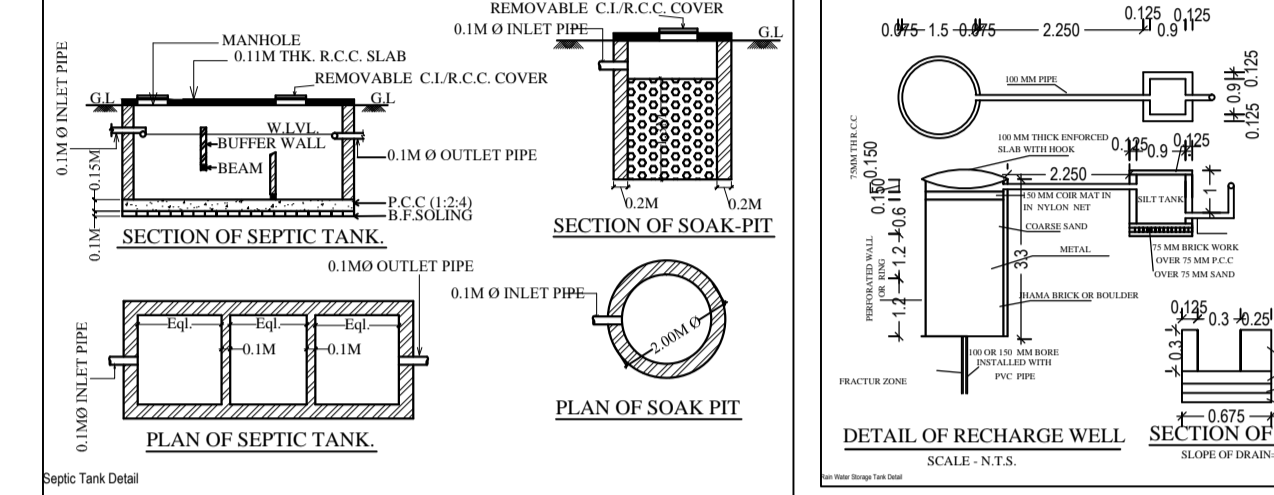
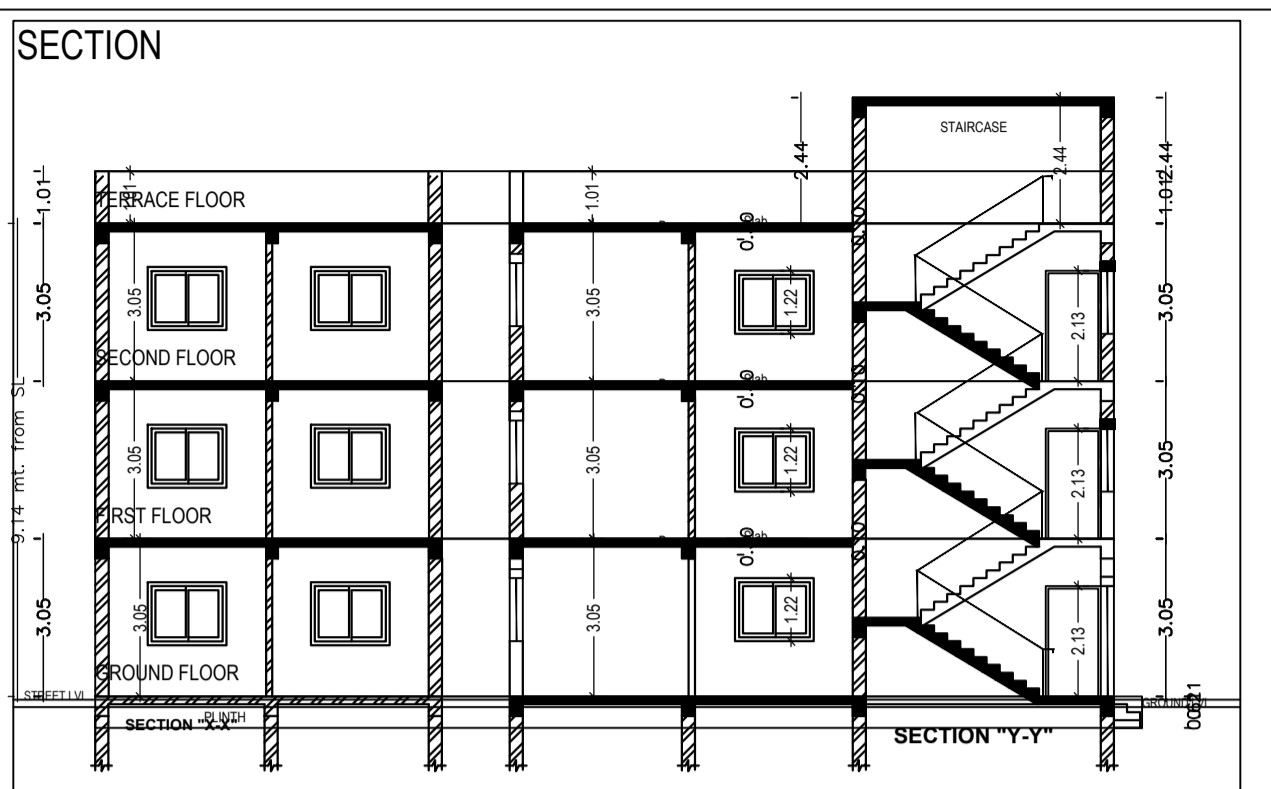
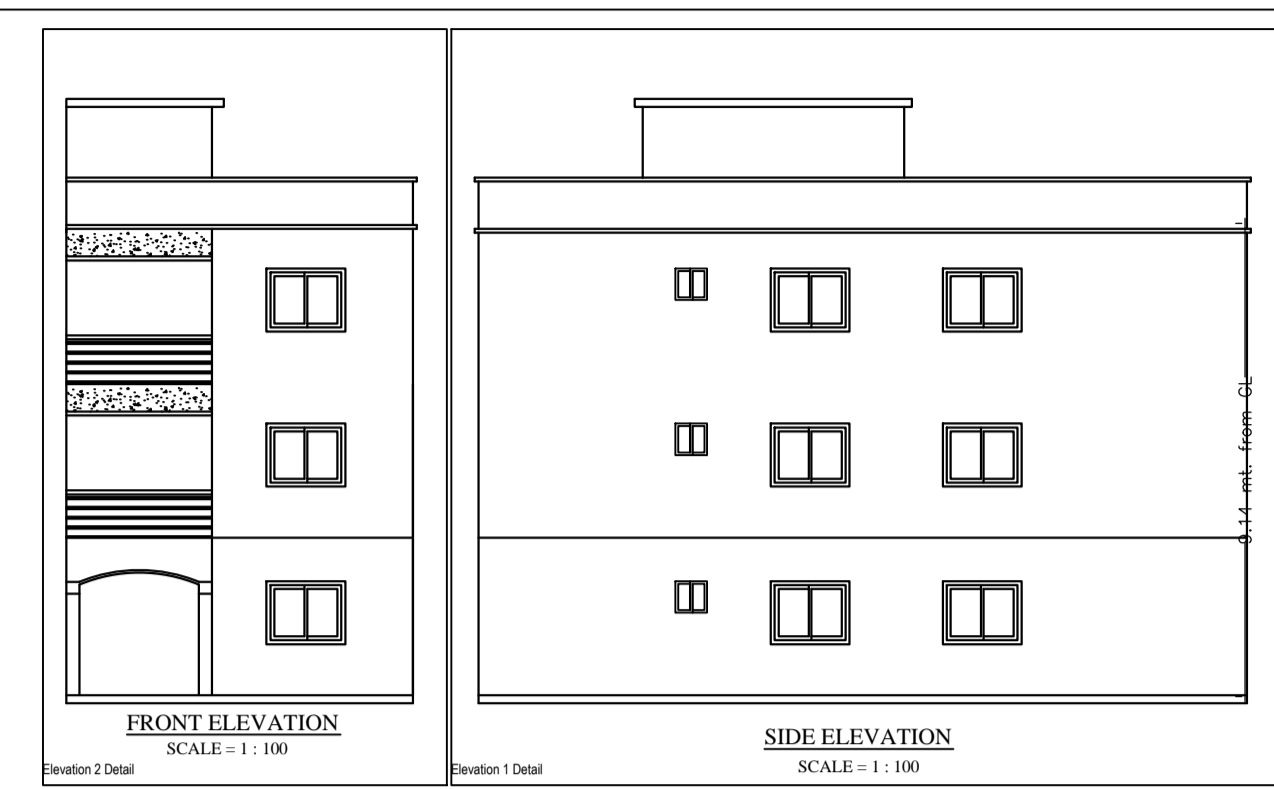

PROPOSED RESIDENTIAL BUILDING PLAN OF  
**(1) SADIQUE IMAM**  
**(2) SAHID HASSAN**  
**(3) FIRDOSH IMAM**  
**(4) KHALID IMAM**  
 S/O. MD. NAYEEM  
 PLOT NO. - 27/1072  
 KATHA NO. - 102  
 VILLAGE - NADIA, LOHARDAGA  
 WARD NO. 8, THANA NO - 195  
 DISTRICT - LOHARDAGA  
 STATE - JHARKHAND.

SIGNATURE OF  
 LAND OWNER

SIGNATURE OF  
 ARCHITECT & ENGINEER

Floor Name	Total Built Up Area (Sq.mt.)	Proposed FAR Area (Sq.mt.)	Total FAR Area (Sq.mt.)	Tent (No.)
Ground Floor	109.23	109.23	109.23	01
First Floor	109.23	109.23	109.23	00
Second Floor	109.23	109.23	109.23	00
Terrace Floor	0.00	0.00	0.00	00
<b>Total</b>	<b>327.69</b>	<b>327.69</b>	<b>327.69</b>	<b>01</b>
Total Number of Same Buildings	1			
<b>Total</b>	<b>327.69</b>	<b>327.69</b>	<b>327.69</b>	<b>01</b>

BUILDING NAME	NAME	LENGTH	HEIGHT	NOS
A ( FIRDOSH IMAM AND SADIQUE IMAM AND SAHID HASSAN AND KHALID IMAM)	D3	0.75	2.13	03
A ( FIRDOSH IMAM AND SADIQUE IMAM AND SAHID HASSAN AND KHALID IMAM)	D2	0.75	2.13	03
A ( FIRDOSH IMAM AND SADIQUE IMAM AND SAHID HASSAN AND KHALID IMAM)	D1	0.90	2.13	12
A ( FIRDOSH IMAM AND SADIQUE IMAM AND SAHID HASSAN AND KHALID IMAM)	D1	1.07	2.13	04
<b>Total</b>	-	-	-	<b>22</b>

BUILDING NAME	NAME	LENGTH	HEIGHT	NOS
A ( FIRDOSH IMAM AND SADIQUE IMAM AND SAHID HASSAN AND KHALID IMAM)	V	0.70	1.00	03
A ( FIRDOSH IMAM AND SADIQUE IMAM AND SAHID HASSAN AND KHALID IMAM)	W1	1.20	2.70	02
A ( FIRDOSH IMAM AND SADIQUE IMAM AND SAHID HASSAN AND KHALID IMAM)	W	2.00	2.70	15
<b>Total</b>	-	-	-	<b>20</b>

FLOOR	Name	Unit/BUA Type	Unit/BUA Area	Carpet Area	No. of Rooms	No. of Tenement
GROUND FLOOR PLAN	SPLIT A	FLAT	172.70	172.55	7	1
<b>Total</b>	-	-	<b>172.70</b>	<b>172.55</b>	<b>21</b>	<b>1</b>