

Proposal Basic Information	
Proposal File No.	LNPBP0002/W21/2020
Owner Name	NIRBEY KUMAR AND ABHAY KUMAR
Khata No.	386
Plot No.	1267
Village Name	Lohardaga
Use	Residential
SubUse	Bungalow Dwelling / Non Apartment

AREA STATEMENT LOHARDAGA NAGAR PARISHAD	VERSION NO: 1.0.46 VERSION DATE: 22/09/2020
PROJECT DETAIL:	
Region: JHARKHAND URBAN LOCAL BODIES	Plot Use: Residential
District: LOHARDAGA	Plot SubUse: Bungalow Dwelling / Non Apartment
Authority: LOHARDAGA NAGAR PARISHAD	Plot/Neary/Religious/Structure: NA
Project No: LNPBP0002/W21/2020	Plot/SubPlot No: 1267
Application Type: General Proposal	North Plot No: - ABHAY KUMAR OR NIRBEY KUMAR
Project Type: Building Permission	South Plot No: - BHUNKASHI PRASAD
Nature of Development: New	East Road Width: 7.07 MTR ROAD
Location of Development Area: Old Area	West Plot No. - OWNERS' NU
AREA DETAILS:	
AREA OF PLOT (Minimum)	SQ.MT
Deduction for NetPlot Area	101.12
Surrender Free of Cost	2.01
Total	99.11
NET AREA OF PLOT (Gross Plot Area - Deduction from Gross Plot Area)	(A-Deductions)
Deduction for Balance Plot Area from Gross Plot Area	14.54
Surrender Free of Cost	2.01
Common Plot	16.55
Total	84.57
BALANCE AREA OF PLOT (Net Plot Area - Residential/Amenity Special)	(A-Deductions)
PLOT AREA FOR COVERAGE (Net Plot Area)	(A-Deductions)
Plot Area for FAR (Net Plot Area + Road Widening Area)	(A-Deductions)
PERMISSIBLE COVERAGE CHECK	
Permissible Coverage area (10.00 %)	66.58
Proposed Coverage Area (62.13 %)	61.58
Total Prop. Coverage Area (62.13 %)	61.58
Balance coverage area (17.87 %)	7.80
FAR CHECK	
Perm. FAR Area (2.00)	202.24
Total Perm. FAR area	202.24
Residential FAR	131.81
Proposed FAR Area	131.81
Total Proposed FAR Area	131.81
Consumed FAR (FAR Util)	1.33
Balance FAR Area	70.43
BUILT UP AREA CHECK	
Total Proposed BuiltUp Area	184.74
ARCHITECT (Regd): SUNIL KUMAR	
ENGINEER (Regd):	
SUPERVISOR (Regd): NIRBEY KUMAR AND ABHAY KUMAR	
OWNER (Regd):	
DEVELOPMENT AUTHORITY: LOCAL BODY	

COLOR INDEX	
PLOT BOUNDARY	Green
ADJUTING ROAD	Red
PROPOSED CONSTRUCTION	Blue
COMMON PLOT	Yellow
ROAD WIDENING AREA	Orange
EXISTING (To be retained)	Light Blue
EXISTING (To be demolished)	Light Yellow

Buildingwise Floor FAR Details				
Floor Name	Building Name		Total	
	A. NIRBEY KUMAR AND ABHAY KUMAR		Total Proposed Built Up Area (Sq.mt)	Total FAR Area (Sq.mt)
Ground Floor	61.58	8.66	61.58	8.66
First Floor	61.58	0.00	61.58	61.58
Second Floor	61.58	0.00	61.58	61.58
Terrace Floor	0.00	0.00	0.00	0.00
Total	184.74	131.82	184.74	131.82

Building USE/SUBUSE Details				
Building Name	Building Use	Building SubUse	Building Structure	
A. NIRBEY KUMAR AND ABHAY KUMAR	Residential	Bungalow Dwelling / Non Apartment	Non-Highrise	

FAR & Tenement Details (Table 4C-1)							
Building	No. of Same Bldg	Total Built Up Area (Sq.mt)	Deductions (Area in Sq.mt)	Proposed FAR Area (Sq.mt)	Add Area in FAR (Sq.mt)	Total Consumed FAR Area (Sq.mt)	Tenmt (No.)
A. NIRBEY KUMAR AND ABHAY KUMAR	1	184.74	52.92	123.16	8.66	131.82	01
Grand Total	1	184.74	52.92	123.16	8.66	131.82	01

Building :A (NIRBEY KUMAR AND ABHAY KUMAR)							
Floor Name	Total Built Up Area (Sq.mt)	Deductions (Area in Sq.mt)	Proposed FAR Area (Sq.mt)	Add Area in FAR (Sq.mt)	Total FAR Area (Sq.mt)	Total Consumed FAR Area (Sq.mt)	Tenmt (No.)
Ground Floor	61.58	0.00	61.58	0.00	61.58	61.58	01
First Floor	61.58	0.00	61.58	0.00	61.58	61.58	01
Second Floor	61.58	0.00	61.58	0.00	61.58	61.58	01
Terrace Floor	0.00	0.00	0.00	0.00	0.00	0.00	01
Total	184.74	0.00	184.74	0.00	184.74	184.74	04
Total Number of Same Buildings	1						
Total	184.74	0.00	184.74	0.00	184.74	184.74	04

SCHEDULE OF DOOR:				
BUILDING NAME	NAME	LENGTH	HEIGHT	NOS
A. NIRBEY KUMAR AND ABHAY KUMAR	D	0.90	2.13	10

SCHEDULE OF WINDOW/VENTILATION:				
BUILDING NAME	NAME	LENGTH	HEIGHT	NOS
A. NIRBEY KUMAR AND ABHAY KUMAR	V	0.60	2.70	02
A. NIRBEY KUMAR AND ABHAY KUMAR	W1	1.50	2.70	04
A. NIRBEY KUMAR AND ABHAY KUMAR	W	2.50	2.70	02

UnitBUA Table for Building :A (NIRBEY KUMAR AND ABHAY KUMAR)						
FLOOR	Name	UnitBUA Type	UnitBUA Area	Carpet Area	No. of Rooms	No. of Tenement
FIRST FLOOR PLAN	SPLIT A	FLAT	96.22	96.15	5	1
SECOND FLOOR PLAN	SPLIT A	FLAT	0.00	0.00	5	0
Total	-	-	96.22	96.15	10	1

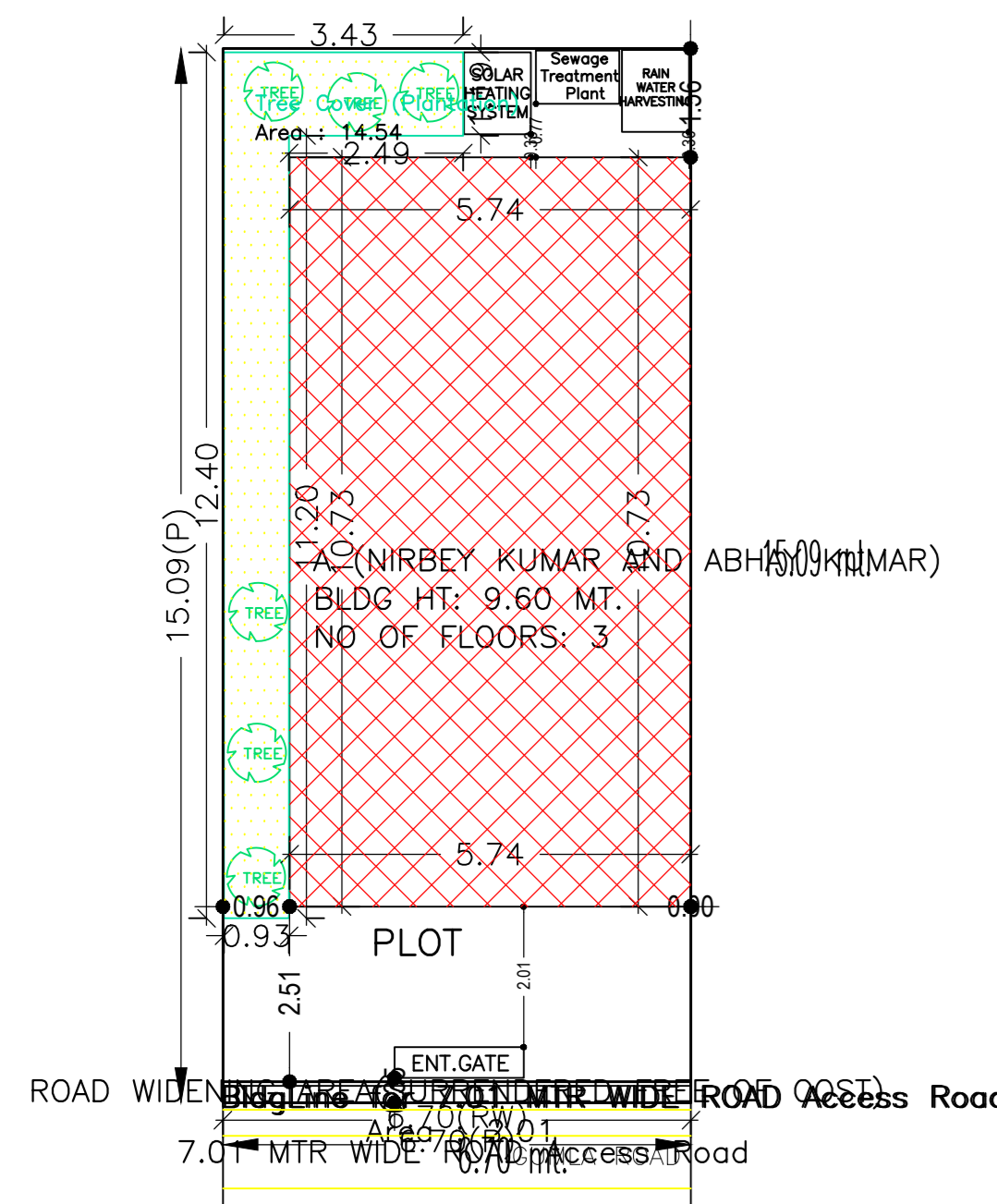

SITE PLAN (SCALE 1:100)

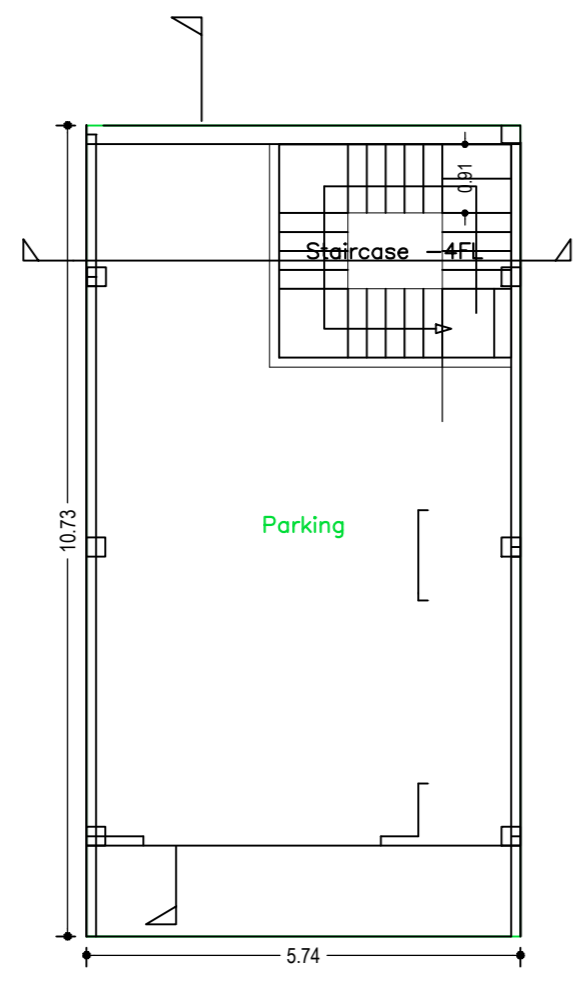

GROUND FLOOR PLAN (SCALE 1:100)

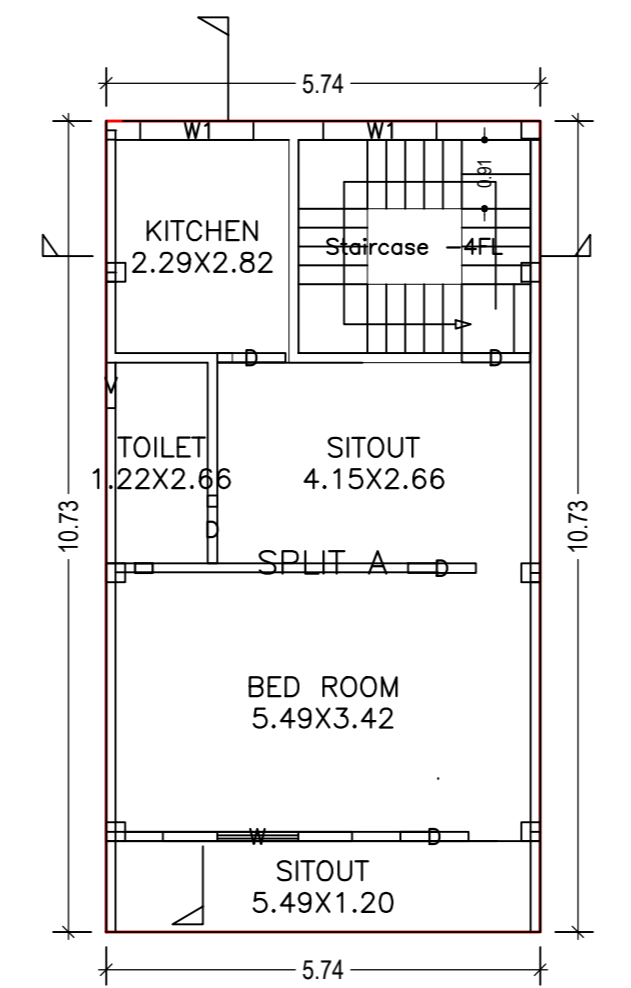

FIRST FLOOR PLAN (Proposed) (SCALE 1:100)

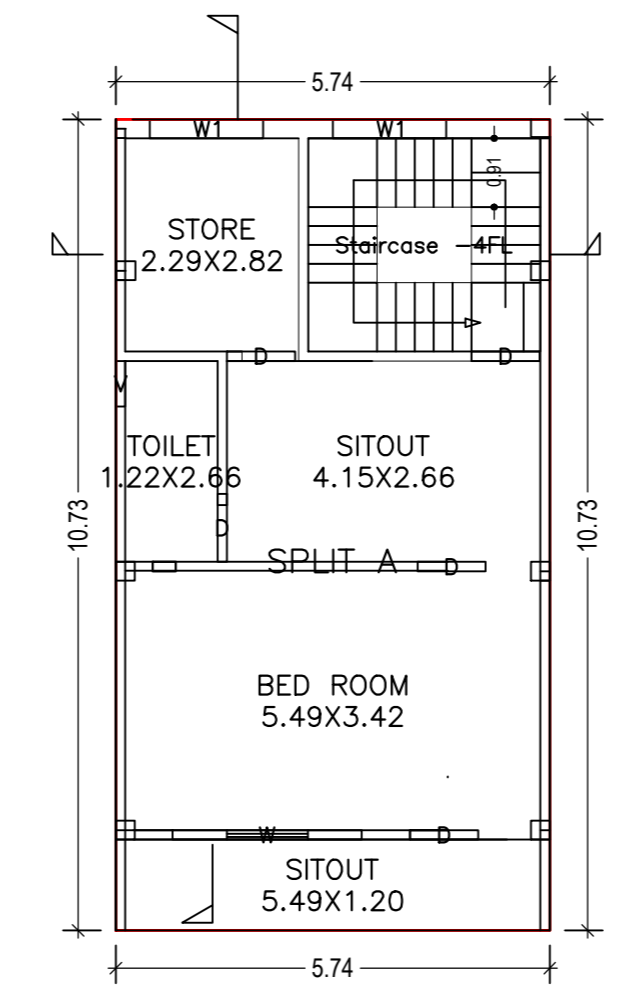

SECOND FLOOR PLAN (Proposed) (SCALE 1:100)

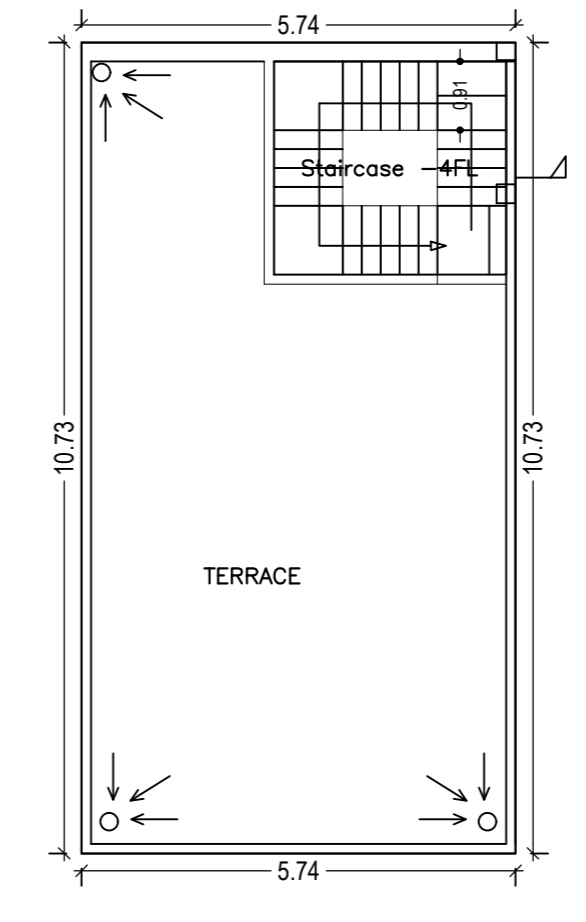

TERRACE FLOOR PLAN (SCALE 1:100)

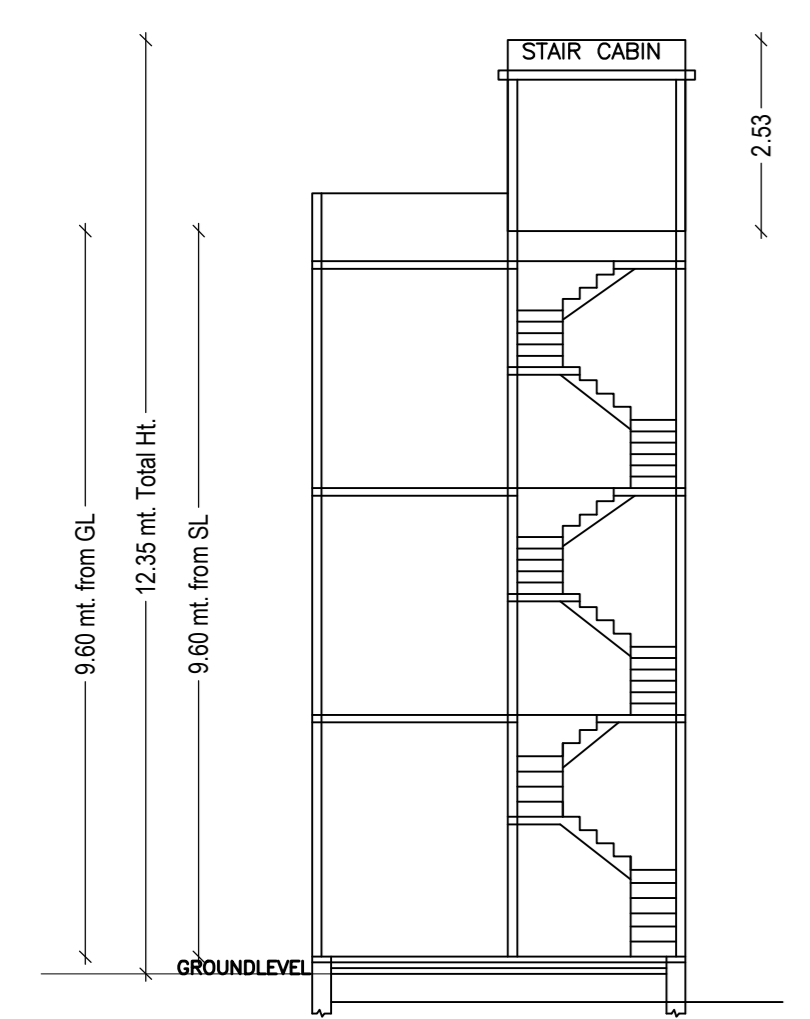

SECTION AT X-X (SCALE 1:100)

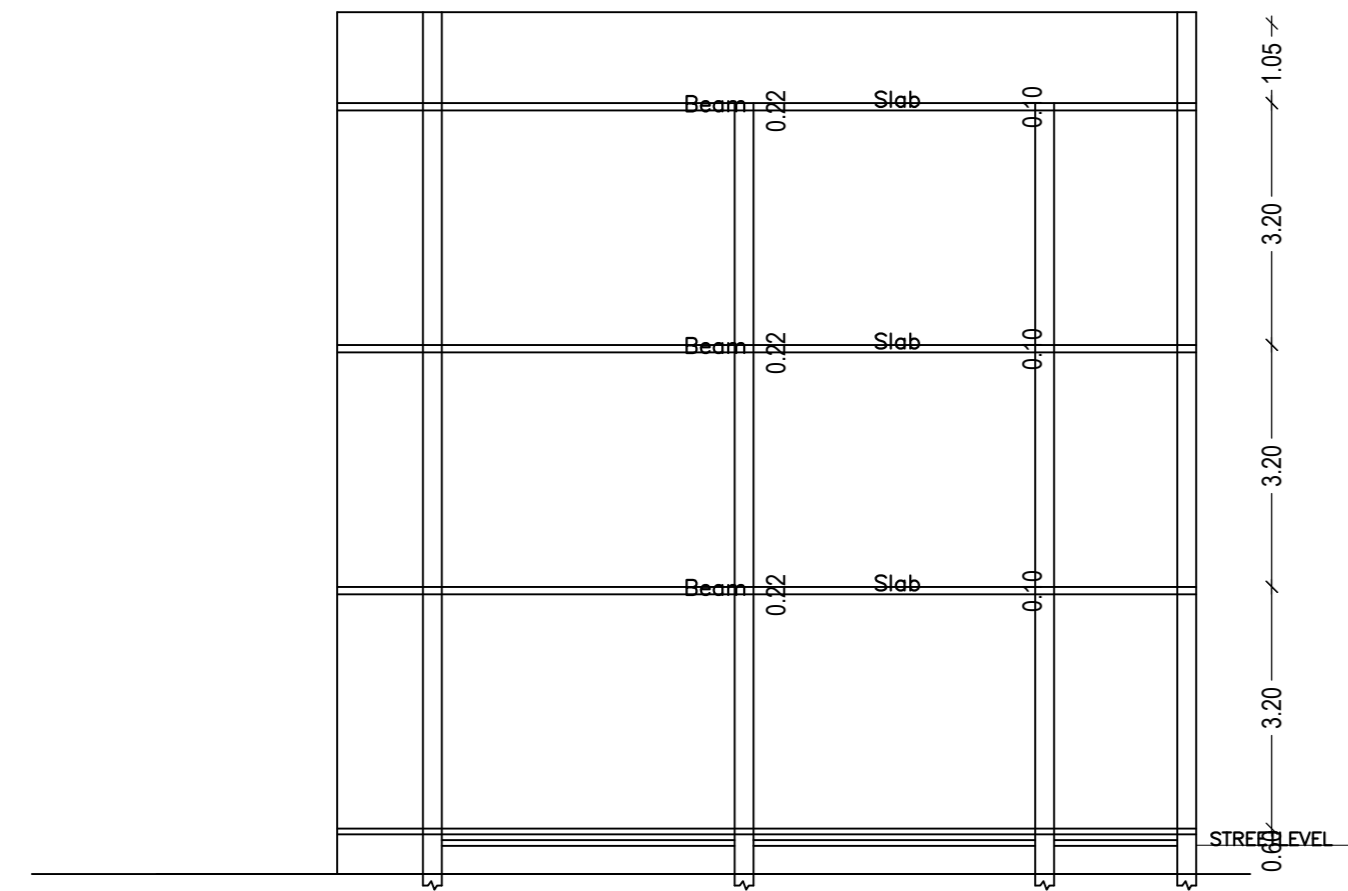

SECTION AT A-A (SCALE 1:100)

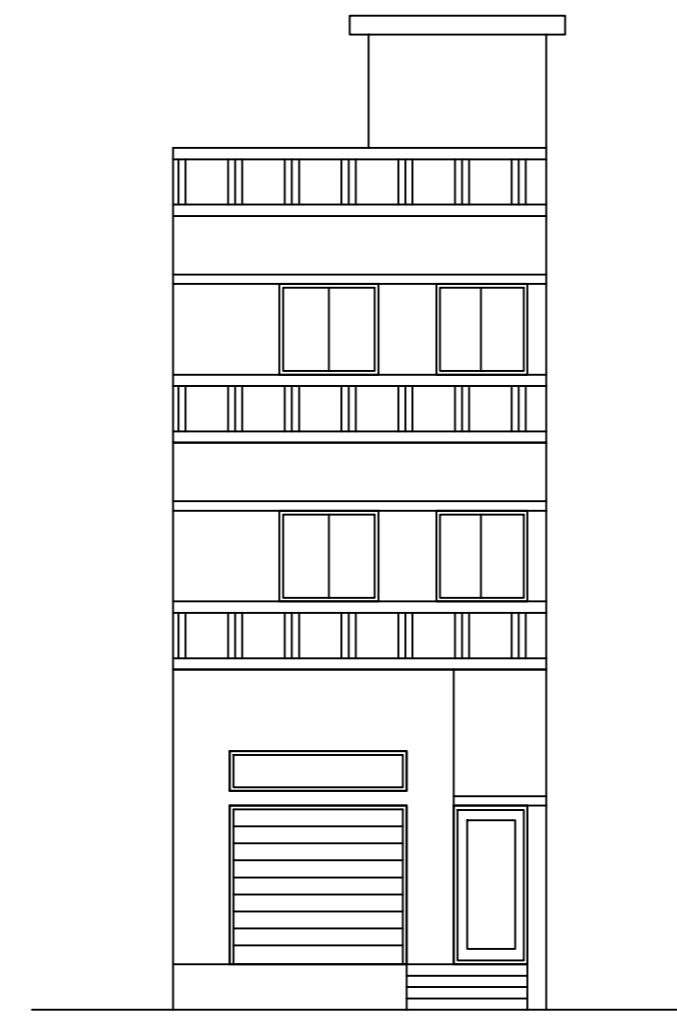

FRONT ELEVATION

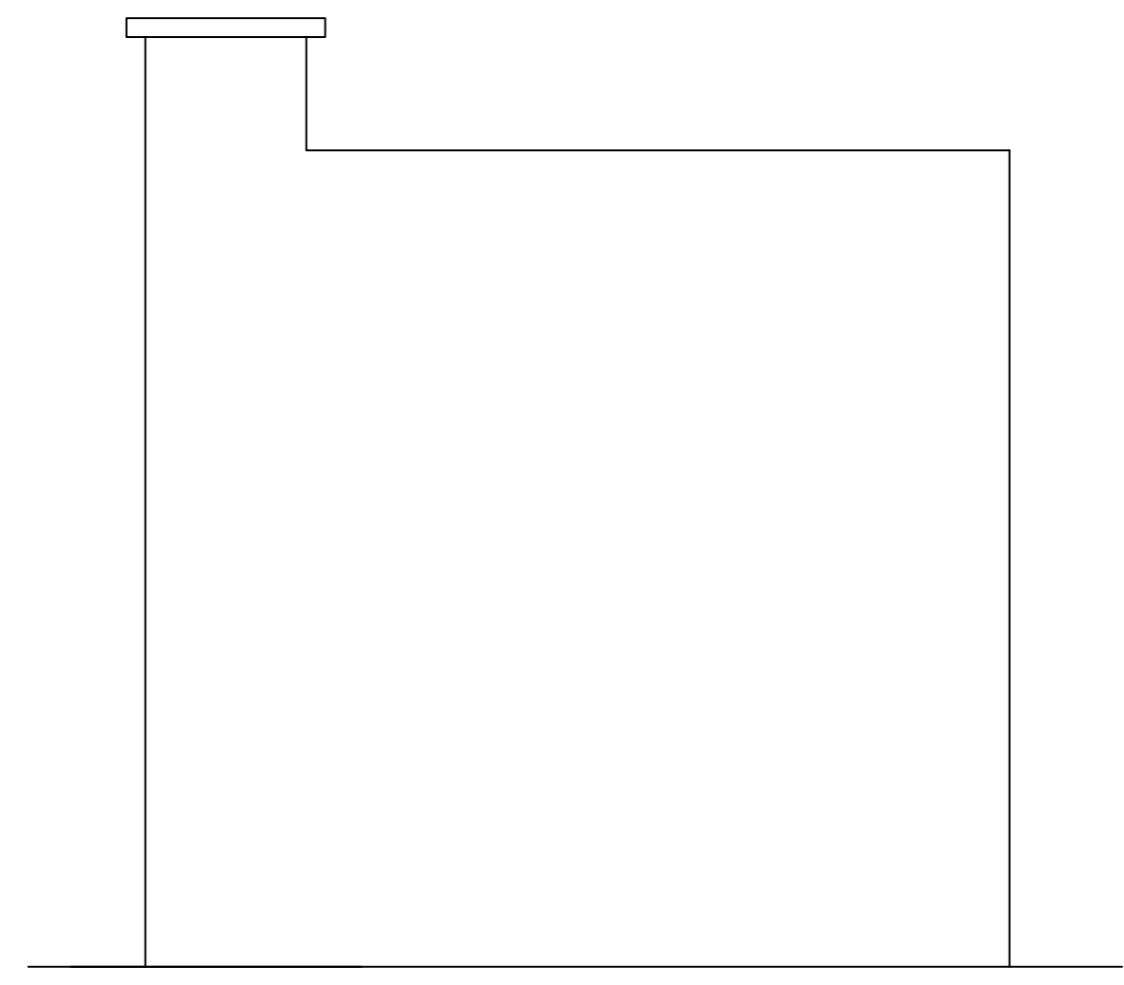

LEFT SIDE ELEVATION (SCALE 1:100)

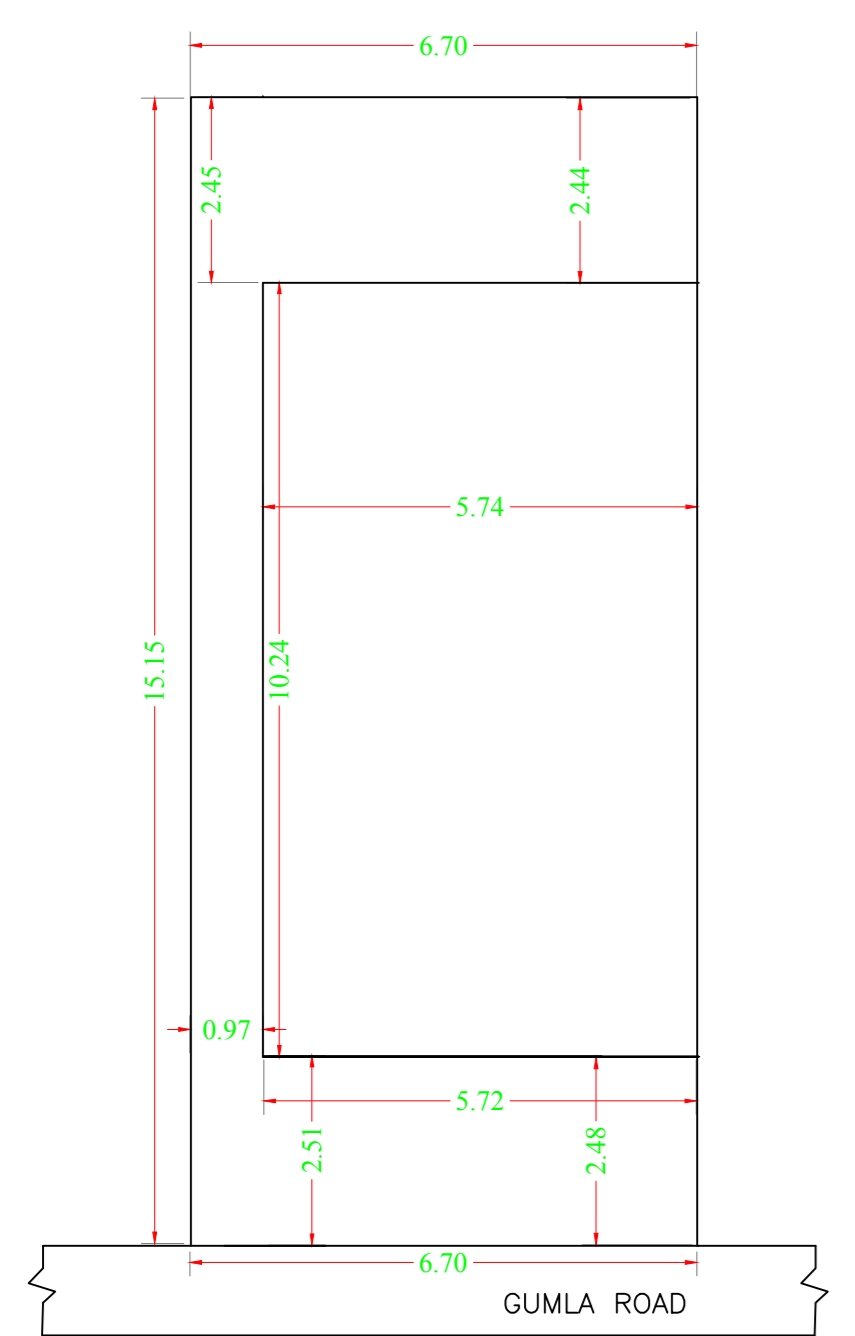

SITE PLAN (SCALE 1:100)

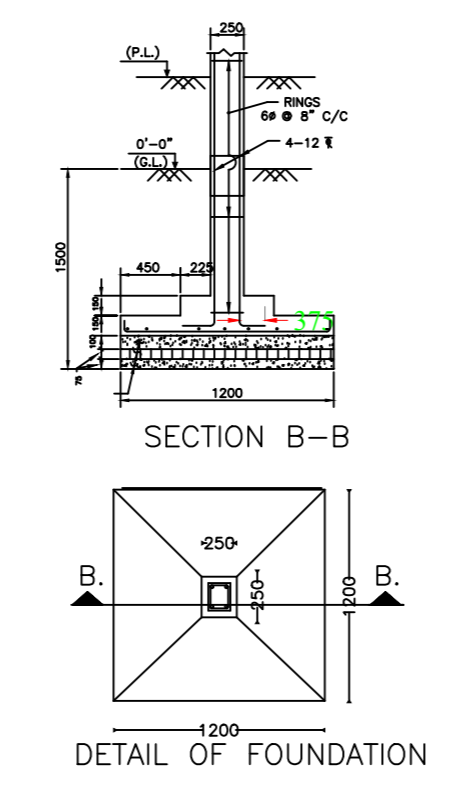
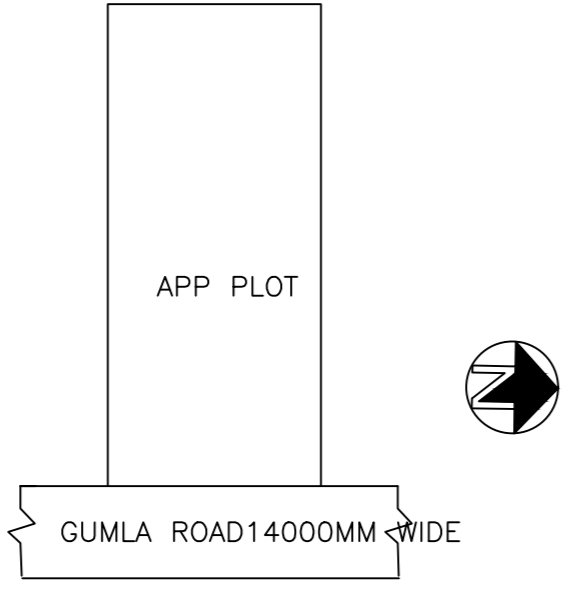

DETAIL OF FOUNDATION

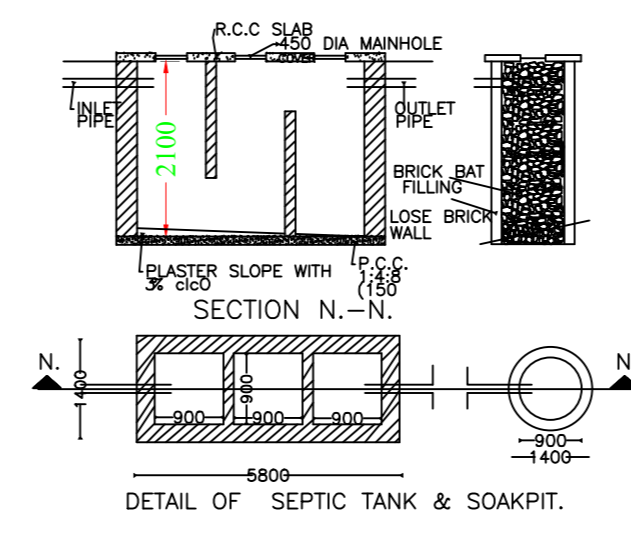

DETAIL OF SEPTIC TANK & SOAKPIT.

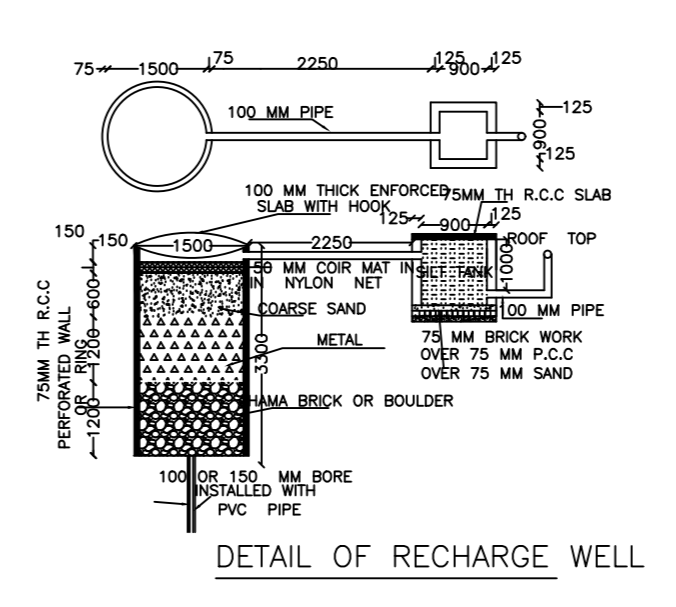

DETAIL OF RECHARGE WELL

LTP NAME AND SIGNATURE SUNIL KUMAR LNPNENG0004/2017	STRUCTURAL ENG'S NAME AND SIGNATURE	BUILDER NAME AND SIGNATURE	DIGITAL SIGNATURE
---	-------------------------------------	----------------------------	-------------------