

SECTION Y-Y
Scale - 1:100

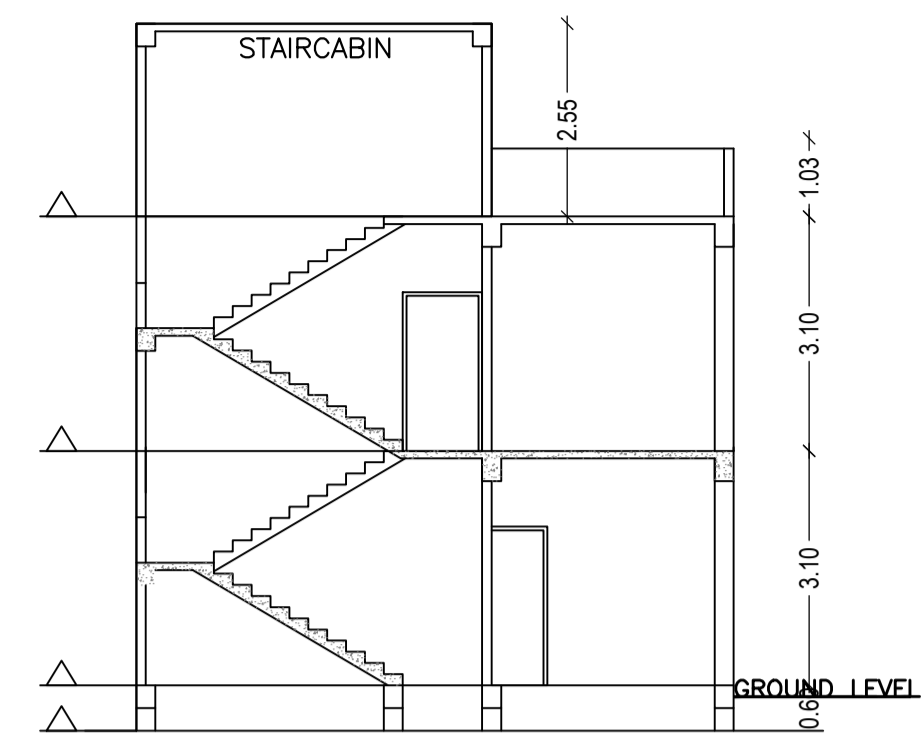

SECTION X-X
Scale - 1:100

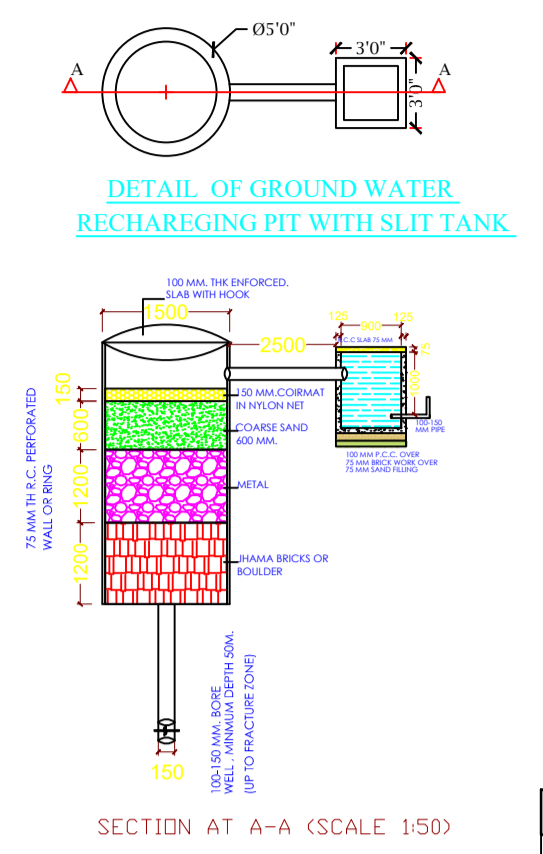

SECTION AT A-A (SCALE 1:50)

Buildingwise Floor FAR Details

Floor Name	Building Name A (MUKESH PRASAD SAHU)		Total	
	Proposed Built Up Area (Sq.mt.)	Proposed FAR Area (Sq.mt.)	Total Proposed Built Up Area (Sq.mt.)	Total FAR Area (Sq.mt.)
Ground Floor	75.96	51.59	75.96	51.59
First Floor	94.80	94.80	94.80	94.80
Terrace Floor	0.00	0.00	0.00	0.00
Total :	170.76	146.39	170.76	146.39

FAR & Tenement Details (Table 4c-1)

Building	No. of Same Bldg	Total Built Up Area (Sq.mt.)	Deductions (Area in Sq.mt.) Parking	Proposed FAR Area (Sq.mt.)		Total FAR Area (Sq.mt.)	Total Consumed Additional FAR Area (Sq.mt.)	Trnmt (No.)
				Resi.	Non-Resi.			
A (MUKESH PRASAD SAHU)	1	170.76	24.37	146.39		146.39	146.39	01
Grand Total :	1	170.76	24.37	146.39		146.39	146.39	01

COLOR INDEX

PLOT BOUNDARY	Black
ABUTTING ROAD	Red
PROPOSED CONSTRUCTION	Green
COMMON PLOT	Yellow
ROAD WIDENING AREA	Blue
EXISTING (To be retained)	Orange
EXISTING (To be demolished)	Pink

UnitBUA Table for Building :A (MUKESH PRASAD SAHU)

FLOOR	Name	UnitBUA Type	UnitBUA Area	Carpet Area	No. of Rooms	No. of Tenement
GROUND FLOOR PLAN	SPLIT A	FLAT	113.96	113.75	4	1
FIRST FLOOR PLAN	SPLIT A	FLAT	0.00	0.00	10	0
Total:	-	-	113.96	113.75	14	1

Building USE/SUBUSE Details

Building Name	Building Use	Building SubUse	Building Structure
A (MUKESH PRASAD SAHU)	Residential	Bungalow/ Dwelling / Non Apartment	Non-Highrise

Proposal Basic Information

Proposal File No.	LNP/IB/0007/W04/2020
Owner Name	MUKESH PRASAD SAHU
Khata No	95
Plot No	184/1113
Village Name	Nadia
Use	Residential
SubUse	Bungalow/ Dwelling / Non Apartment

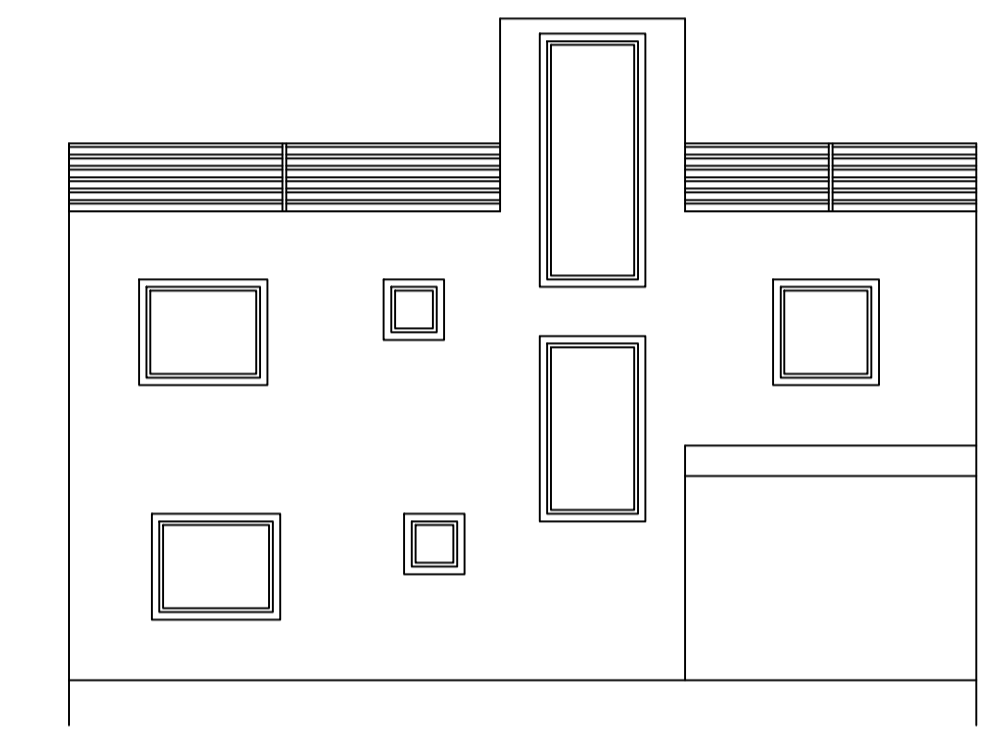

BACK SIDE ELEVATION
Scale - 1:100

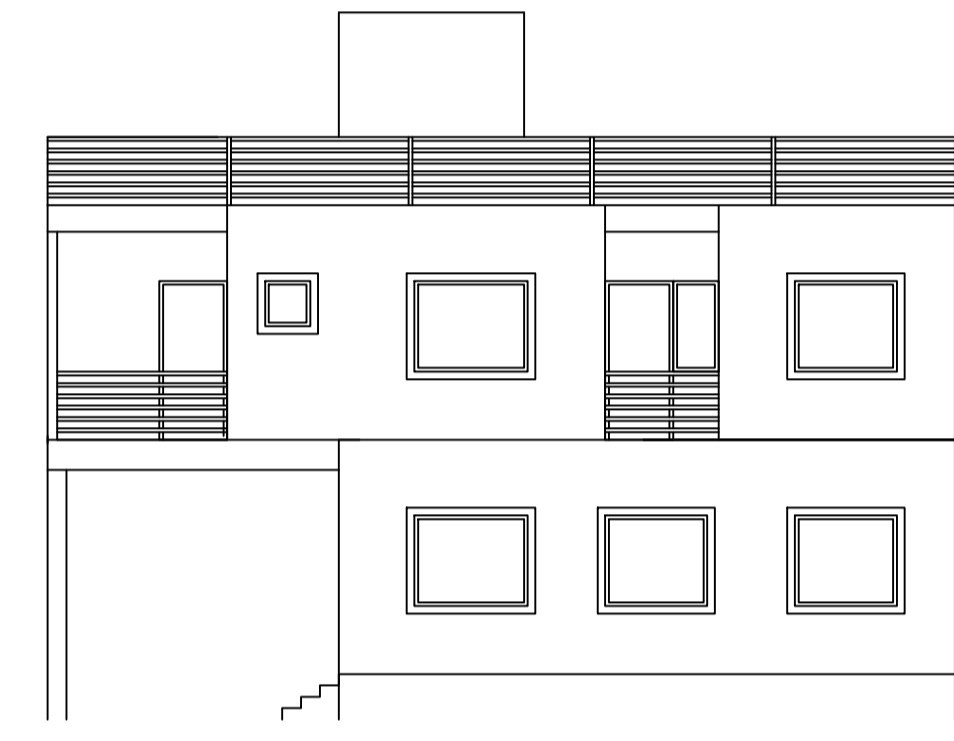

FRONT ELEVATION
Scale - 1:100

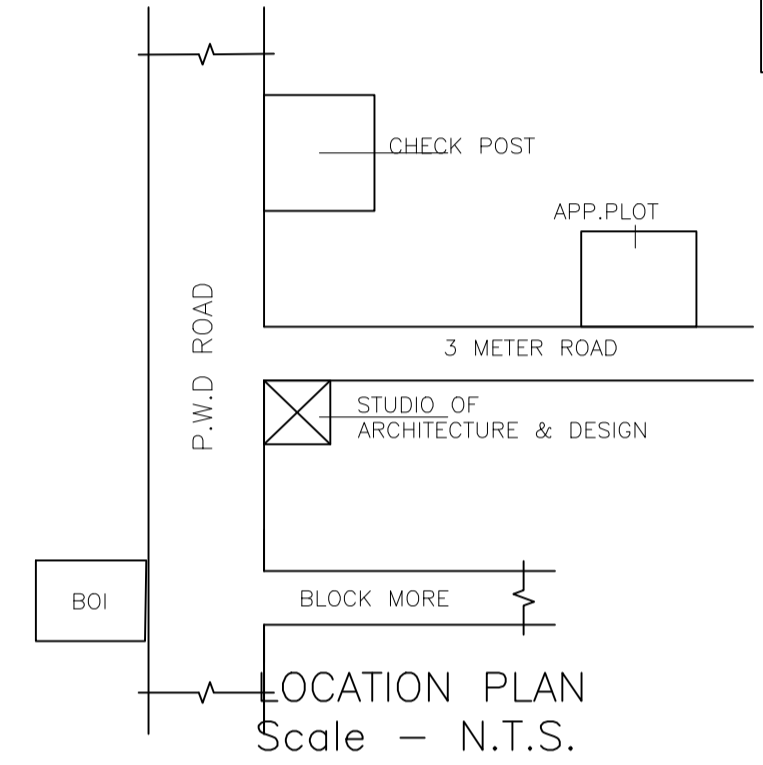

LOCATION PLAN
Scale - N.T.S.

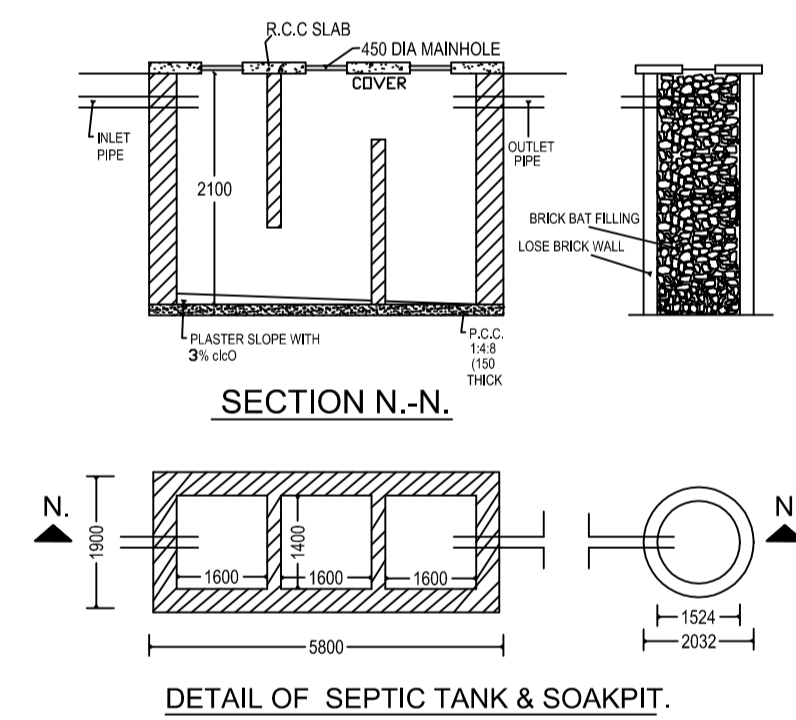
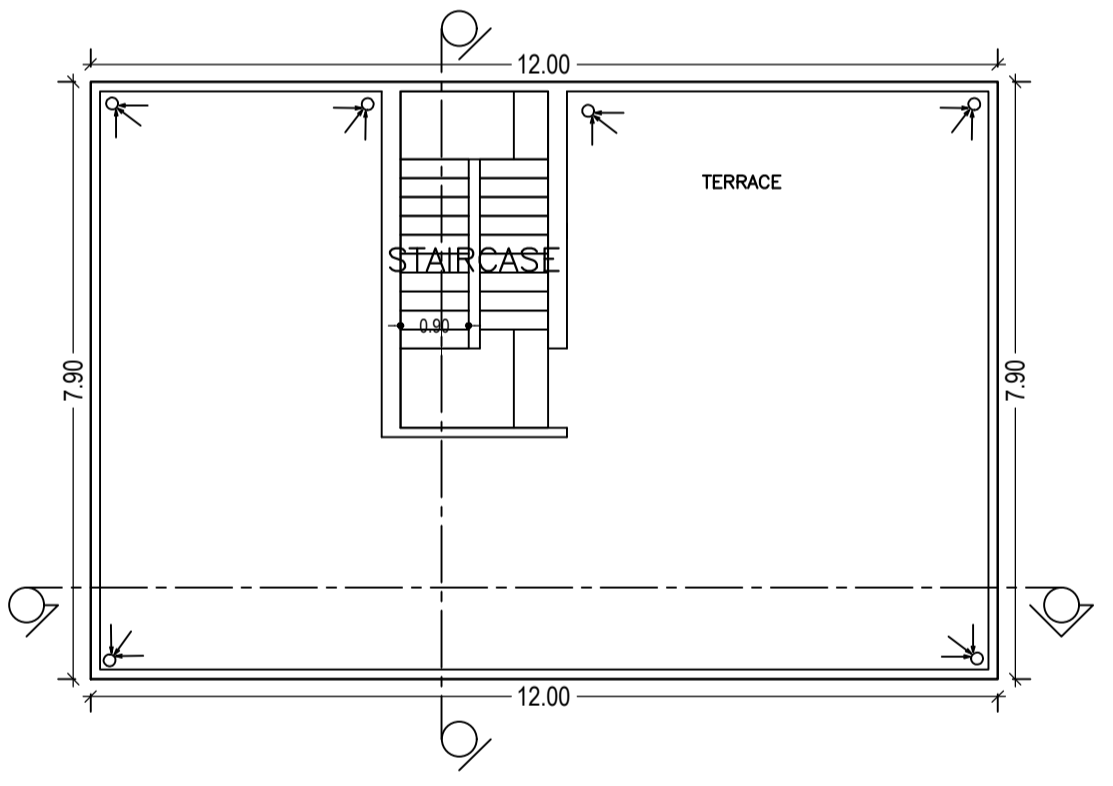

DETAIL OF SEPTIC TANK & SOAKPIT.

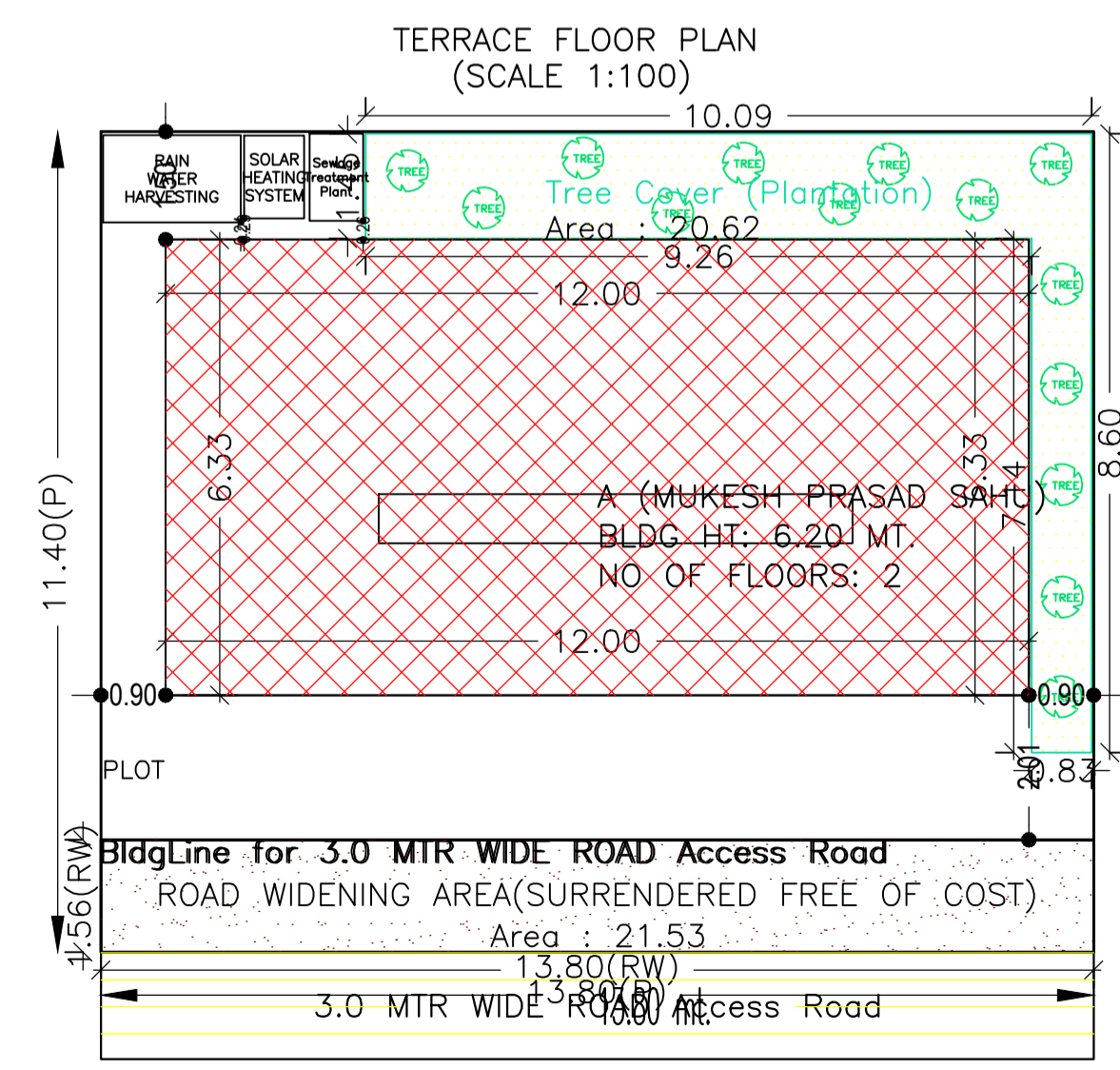

SITE PLAN
ISO_A1_(841.00 x 594.00_MM)

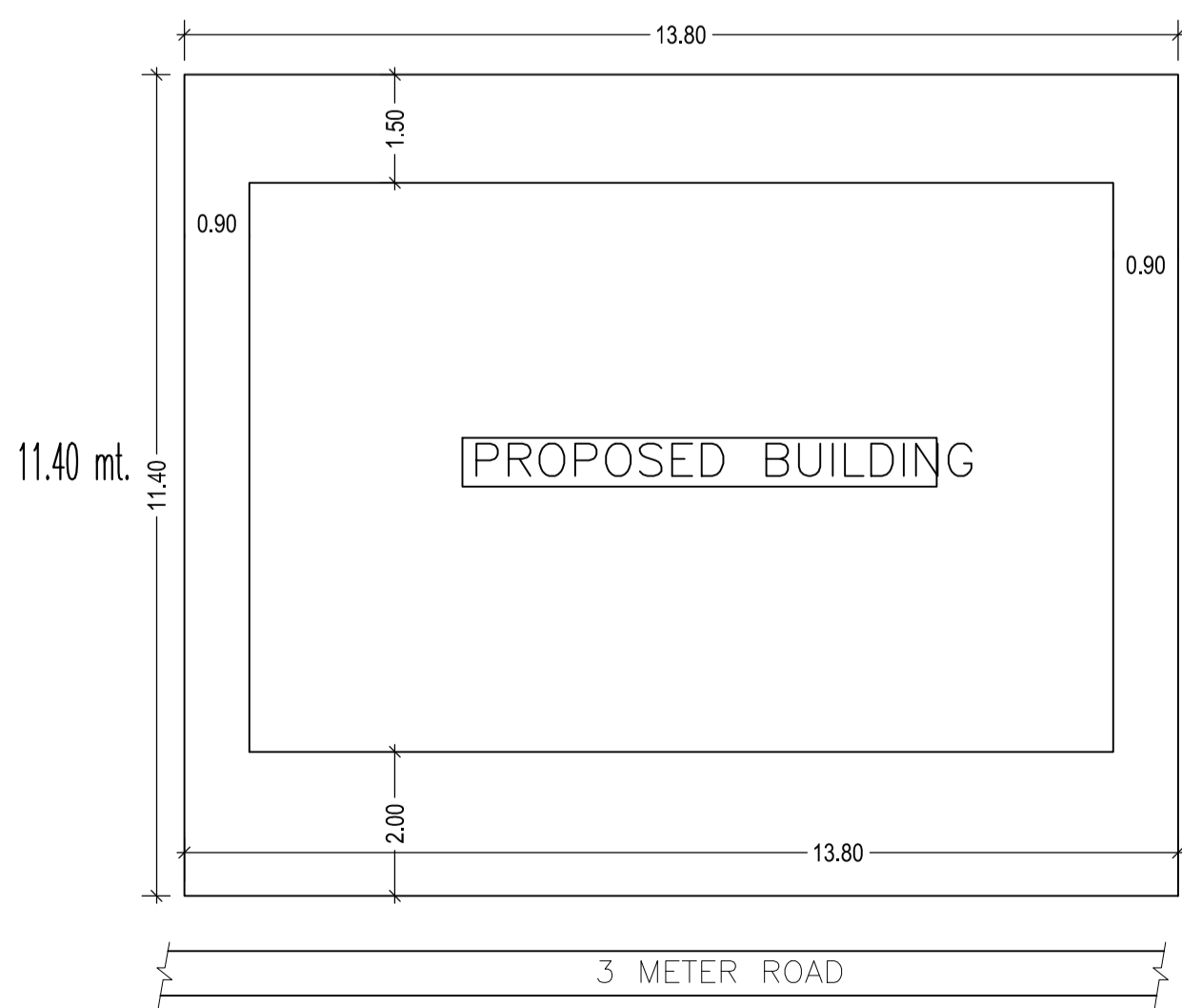

SITE PLAN
Scale - 1:100

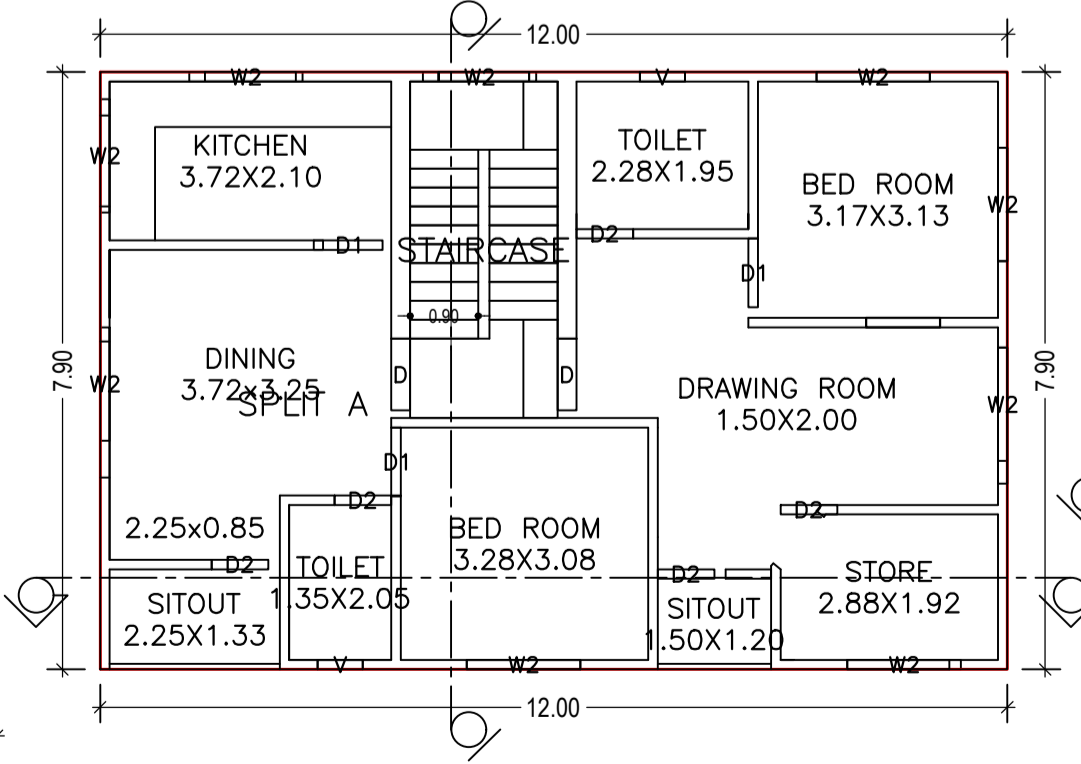

FIRST FLOOR PLAN
(Proposed)
(SCALE 1:100)

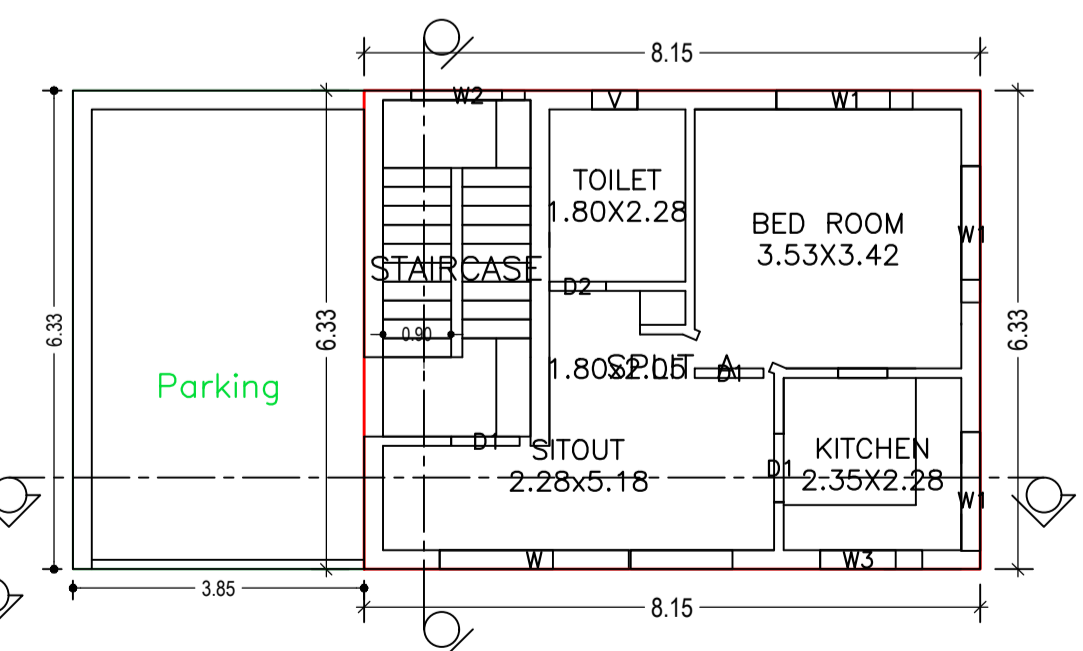

GROUND FLOOR PLAN
(Proposed)
(SCALE 1:100)

AREA STATEMENT LOHARDAGA NAGAR PARISHAD	VERSION NO.: 1.0.44 VERSION DATE: 29/04/2019
PROJECT DETAIL:	
Region: JHARKHAND URBAN LOCAL BODIES	Plot Use: Residential
District: LOHARDAGA	Plot SubUse: Bungalow/ Dwelling / Non Apartment
Authority: LOHARDAGA NAGAR PARISHAD	Plot/Nearby/Religious/Structure: NA
Inward No: LNP/IB/0007/W04/2020	Plot/SubPlot No: 184/1113
Application Type: General Proposal	North: Road Width - 3
Project Type: Building Permission	South: Plot No. - 198
Nature of Development: New	East: Plot No. - 1113
Location of Development Area: Old Area	West: Plot No. - 1113
AREA DETAILS:	SQ.MT.
AREA OF PLOT (Minimum)	(A) 157.32
Deduction for NetPlot Area	
Surrender Free of Cost	21.53
Total	21.53
NET AREA OF PLOT(Gross Plot Area - Deduction from Gross Plot area)	(A-Deductions) 135.79
Deduction for Balance Plot Area(from Gross Plot Area)	
Surrender Free of Cost	21.53
Common Plot	20.62
Total	42.15
BALANCE AREA OF PLOT(Net Plot Area - Recreational/Amenity space)	(A-Deductions) 115.17
PLOT AREA FOR COVERAGE(Net Plot Area)	(A-Deductions) 135.79
Plot Area for FAR (Net Plot Area + RoadWidening Area)	(A-Deductions) 157.32
COVERAGE CHECK	
Permissible Coverage area (70.00 %)	95.05
Proposed Coverage Area (55.94 %)	75.96
Total Prop. Coverage Area (55.94 %)	75.96
Balance coverage area (14.06 %)	19.09
FAR CHECK	
Perm. FAR Area (1.20)	188.78
Total Perm. FAR area	188.78
Residential FAR	146.39
Proposed FAR Area	146.39
Total Proposed FAR Area	146.39
Consumed FAR (Factor)	0.93
Balance FAR Area	42.39
BUILT UP AREA CHECK	
Total Proposed BuiltUp Area	170.76
ARCHITECT (Regd)	Ashish Deep Toppo
ENGINEER (Regd)	
SUPERVISOR (Regd)	
OWNER (Regd)	MUKESH PRASAD SAHU
DEVELOPMENT AUTHORITY	LOCAL BODY

SCHEDULE OF DOOR:

BUILDING NAME	NAME	LENGTH	HEIGHT	NOS
A (MUKESH PRASAD SAHU)	D2	0.75	2.13	06
A (MUKESH PRASAD SAHU)	D1	0.91	2.13	06
A (MUKESH PRASAD SAHU)	D	0.95	2.13	02

SCHEDULE OF WINDOW/VENTILATION:

BUILDING NAME	NAME	LENGTH	HEIGHT	NOS
A (MUKESH PRASAD SAHU)	V	0.60	2.70	03
A (MUKESH PRASAD SAHU)	W3	1.00	2.70	01
A (MUKESH PRASAD SAHU)	W2	1.50	2.70	10
A (MUKESH PRASAD SAHU)	W1	1.57	2.70	01
A (MUKESH PRASAD SAHU)	W1	1.80	2.70	02
A (MUKESH PRASAD SAHU)	W	2.50	2.70	01

Building :A (MUKESH PRASAD SAHU)

Floor Name	Total Built Up Area (Sq.mt.)	Deductions (Area in Sq.mt.) Parking	Proposed FAR Area (Sq.mt.) Resi.	Total FAR Area (Sq.mt.)	Total Consumed Additional FAR Area (Sq.mt.)	Trnmt (No.)
Ground Floor	75.96	24.37	51.59	51.59	51.59	01
First Floor	94.80	0.00	94.80	94.80	94.80	00
Terrace Floor	0.00	0.00	0.00	0.00	0.00	00
Total	170.76	24.37	146.39	146.39	146.39	01
Total Number of Same Buildings	1					
Total :	170.76	24.37	146.39	146.39	146.39	01

LTP NAME AND SIGNATURE	STRUCTURAL ENG'S NAME AND SIGNATURE	BUILDER NAME AND SIGNATURE	DIGITAL SIGNATURE
Ashish Deep Toppo LNP/ARC/0009/2017			