

Project Title :SMT SAHITA SAHU

PROJECT TITLE	PROJECT NO.	DATE
SMT SAHITA SAHU	1234	2024-10-27

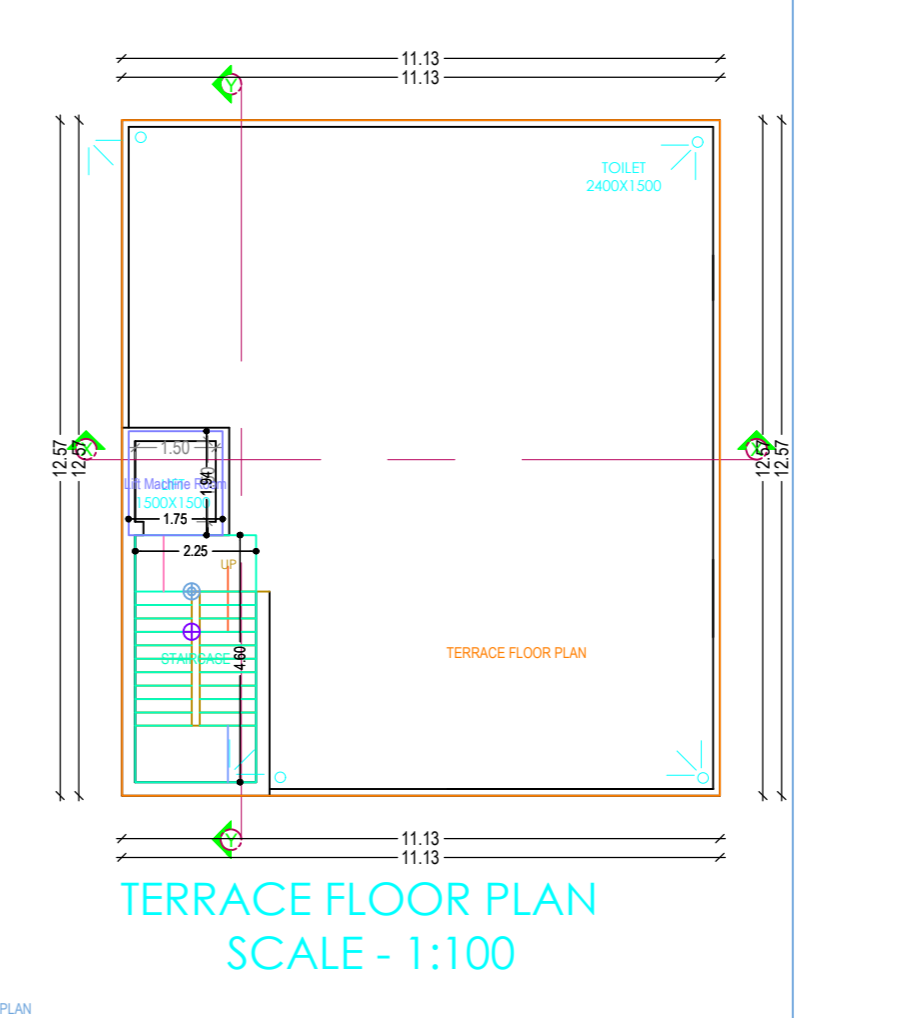
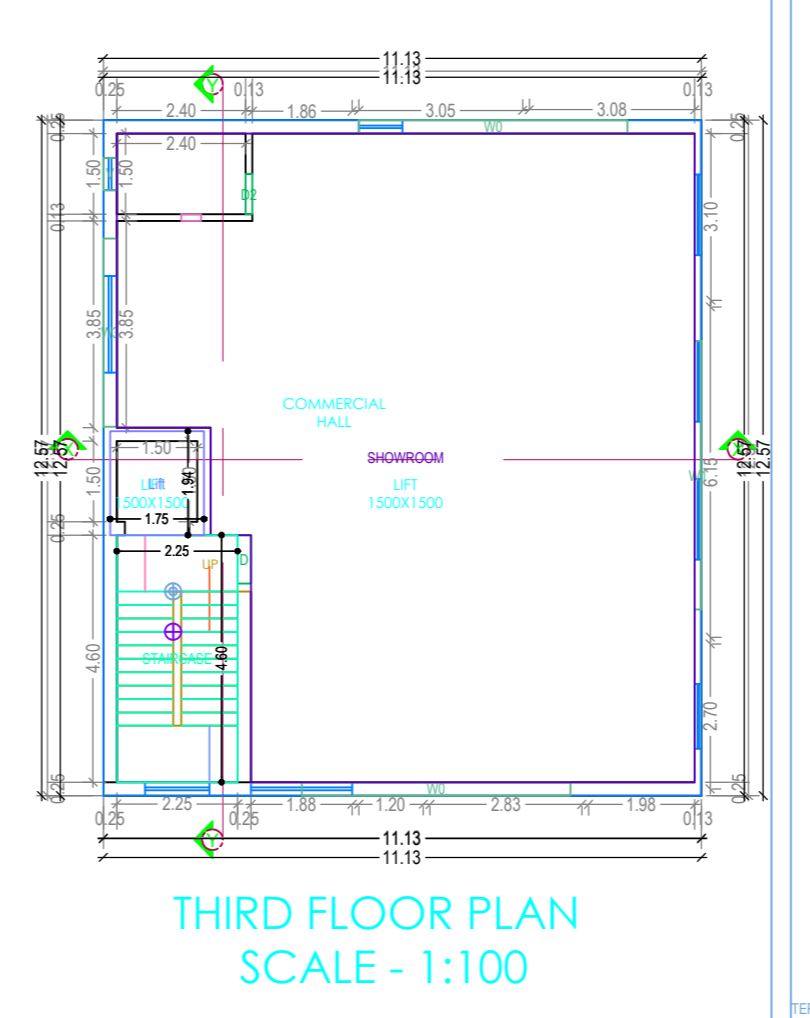
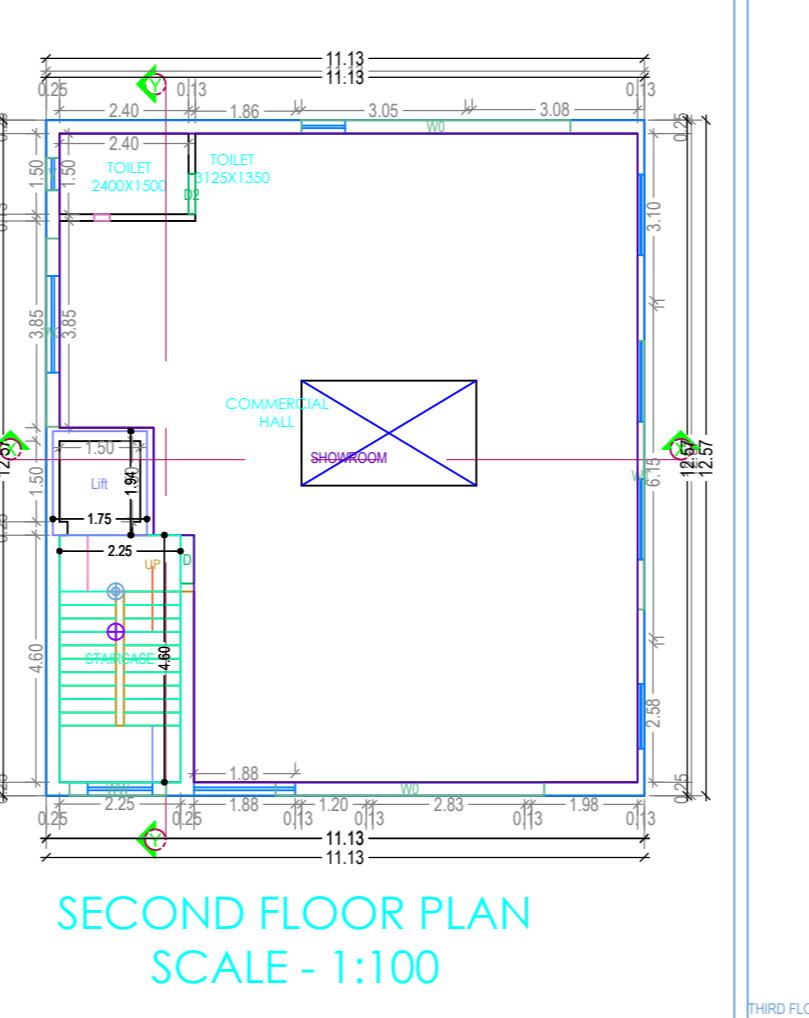
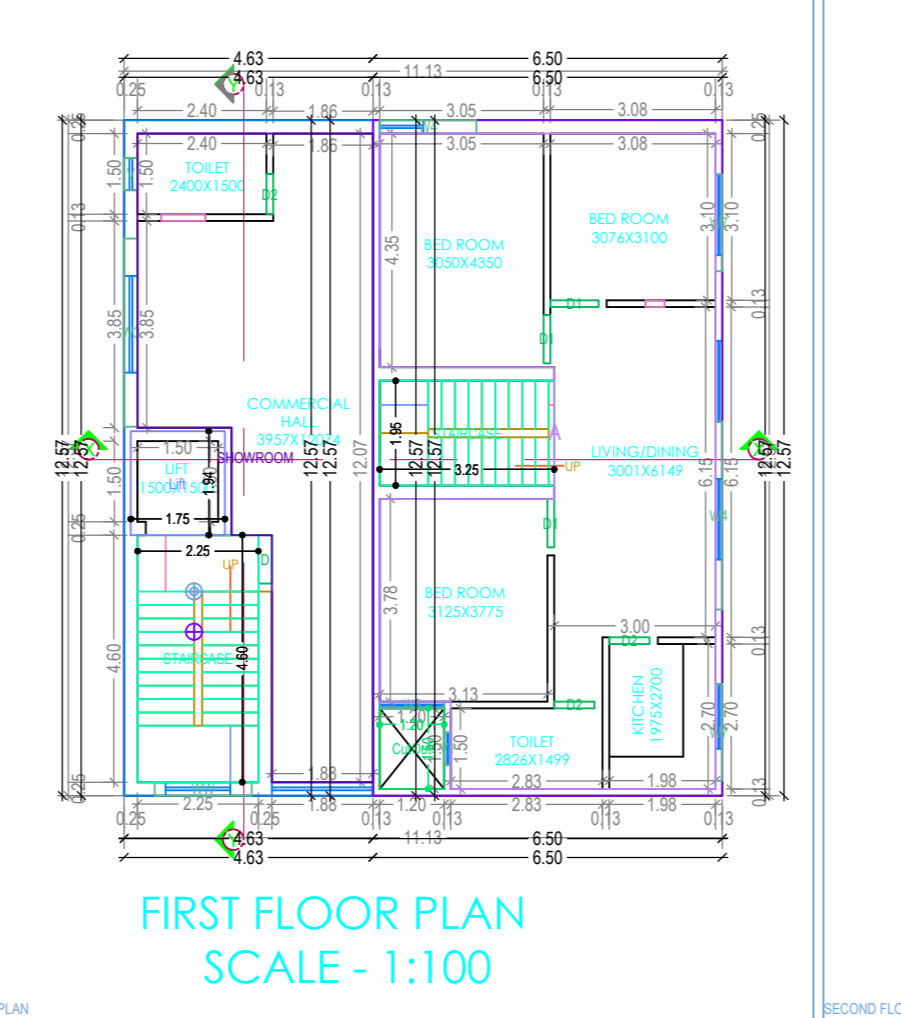
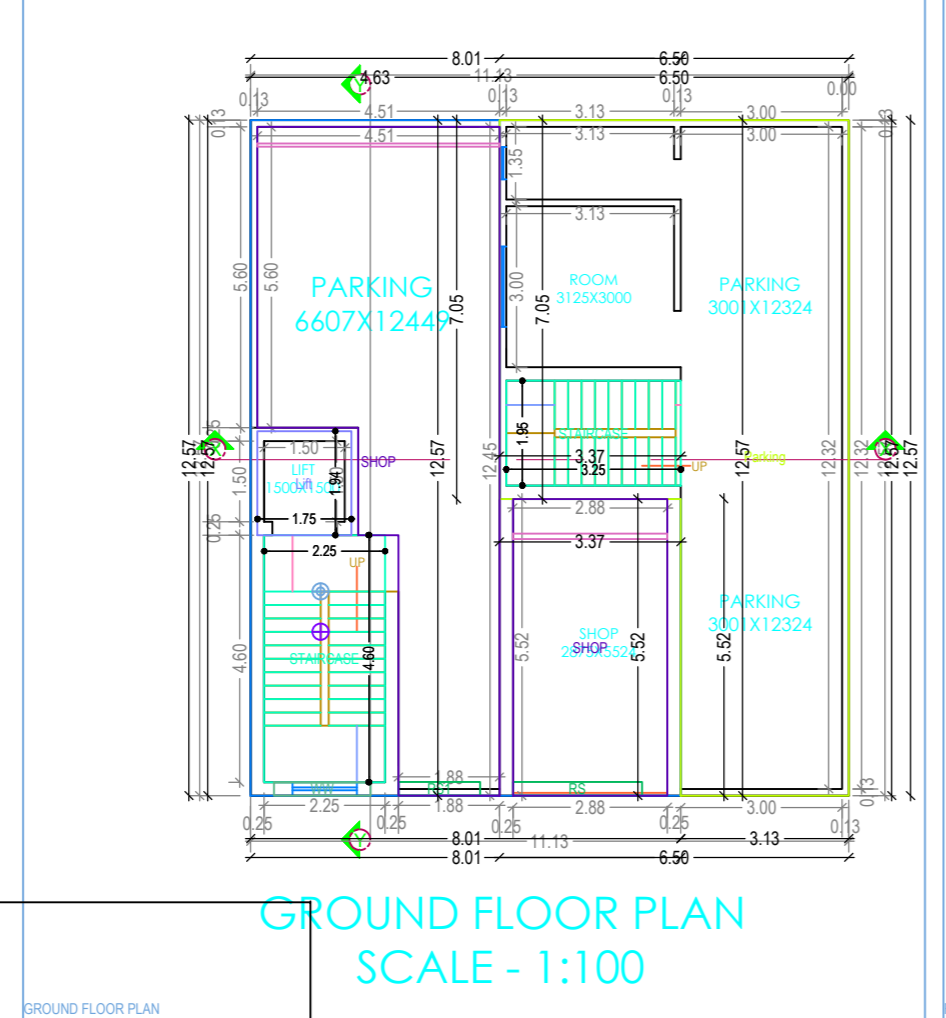
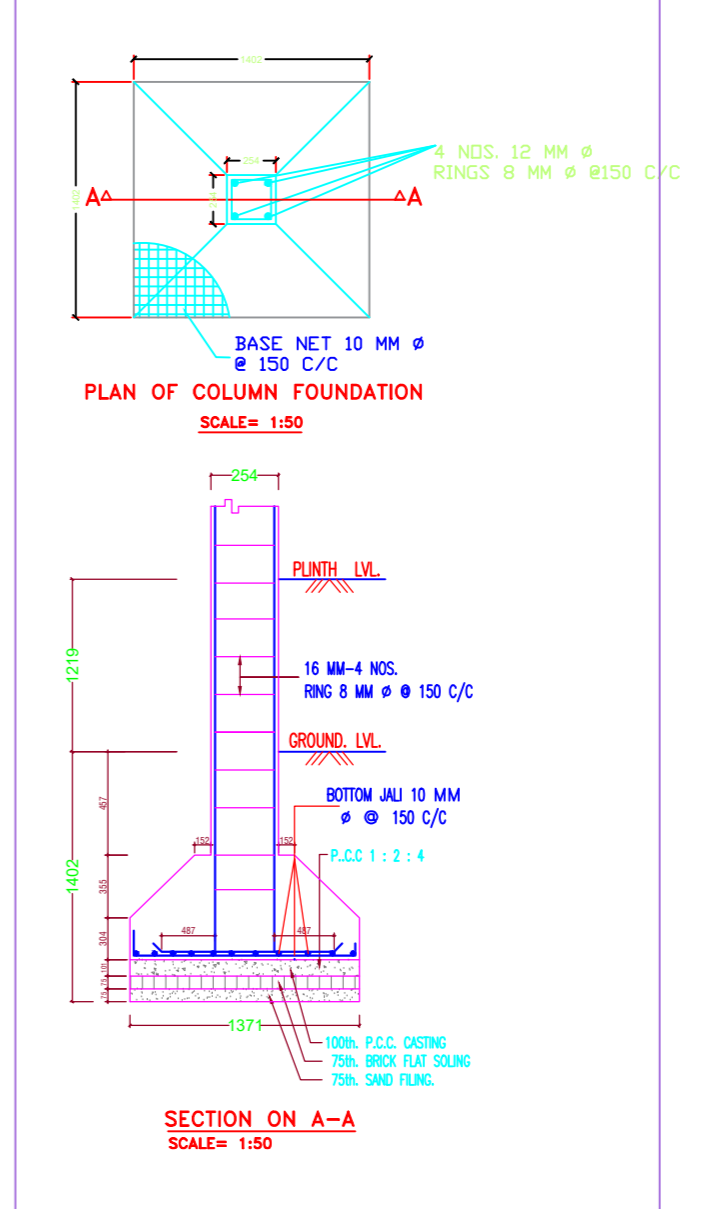
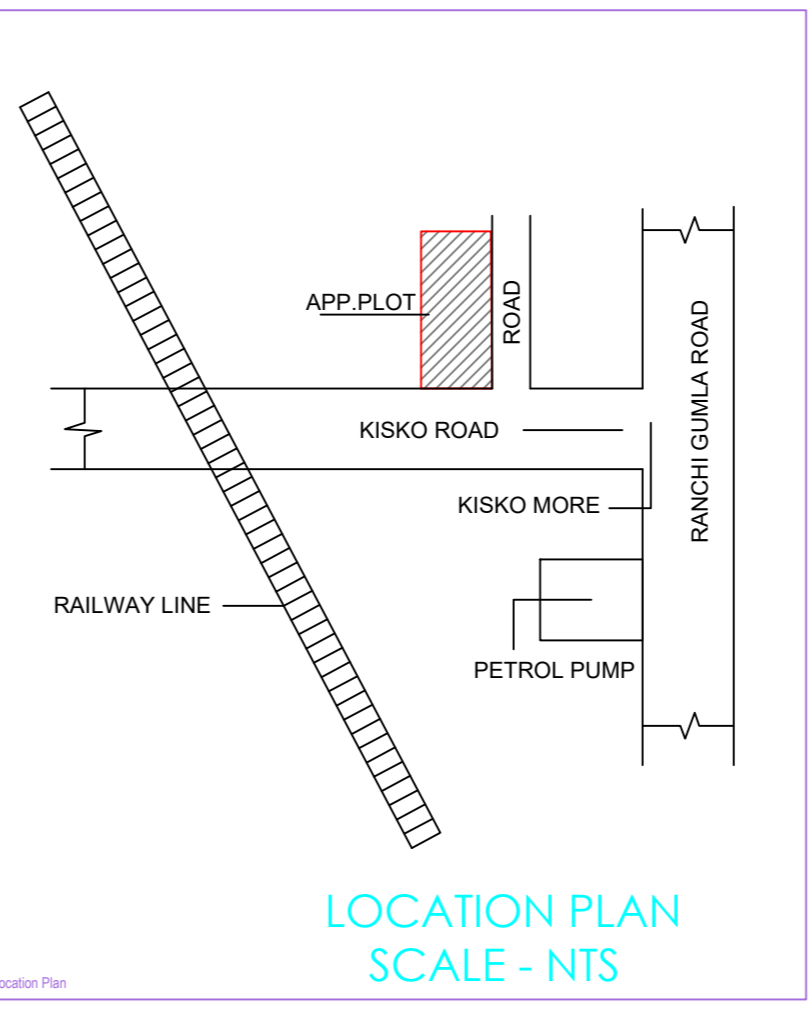
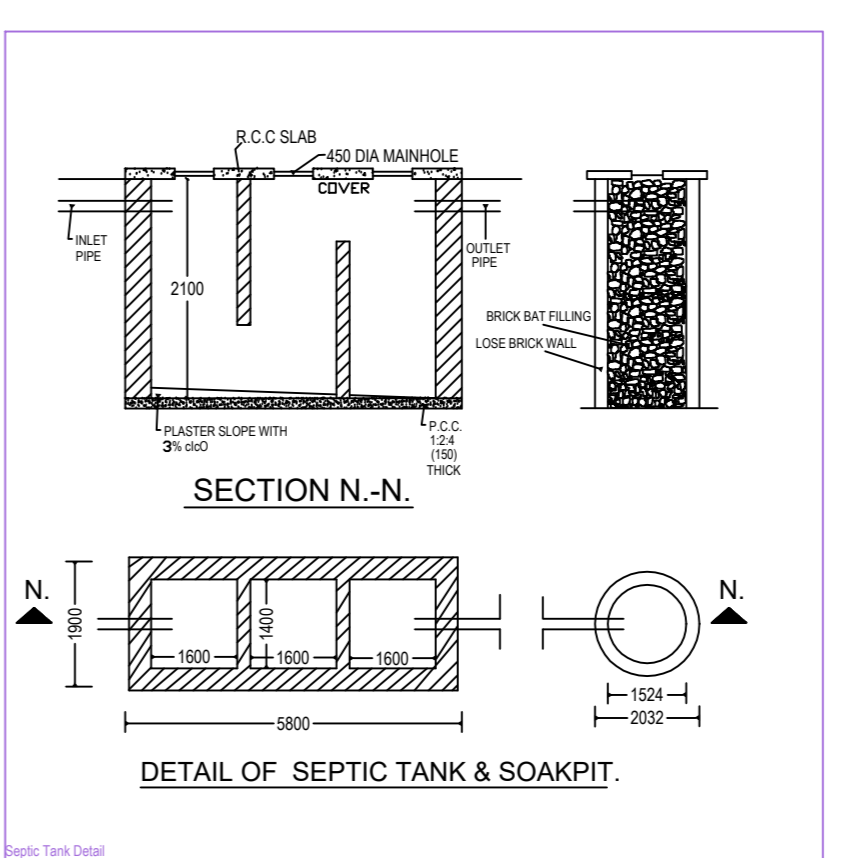
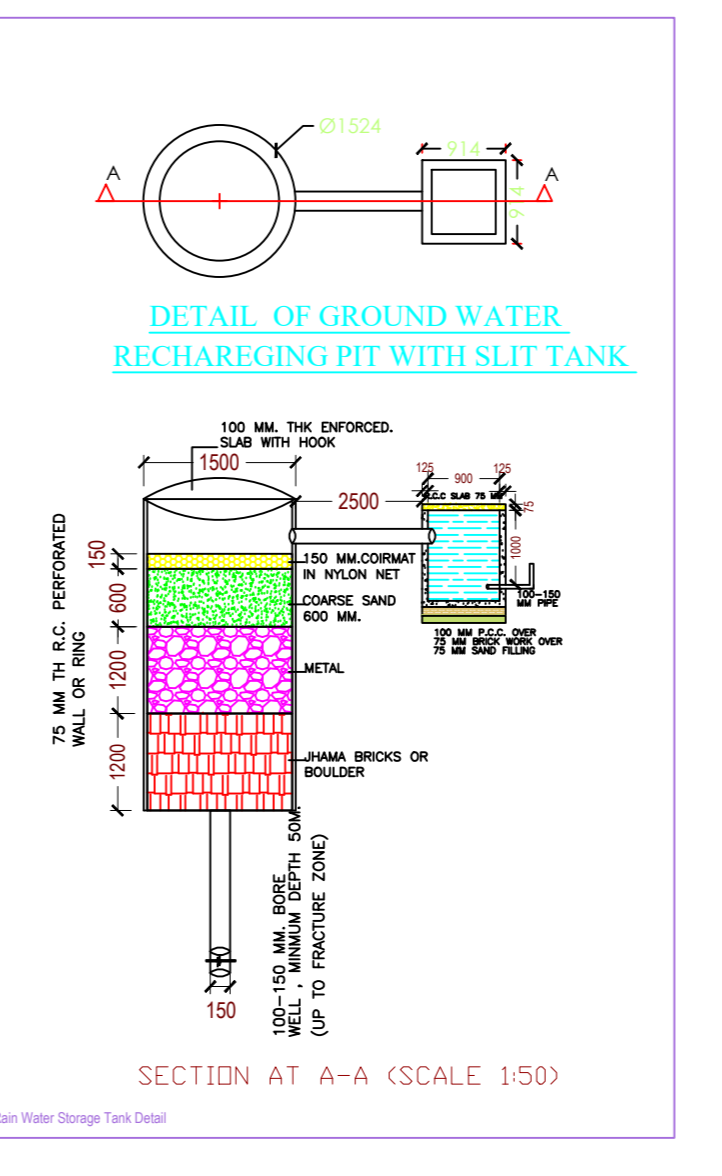
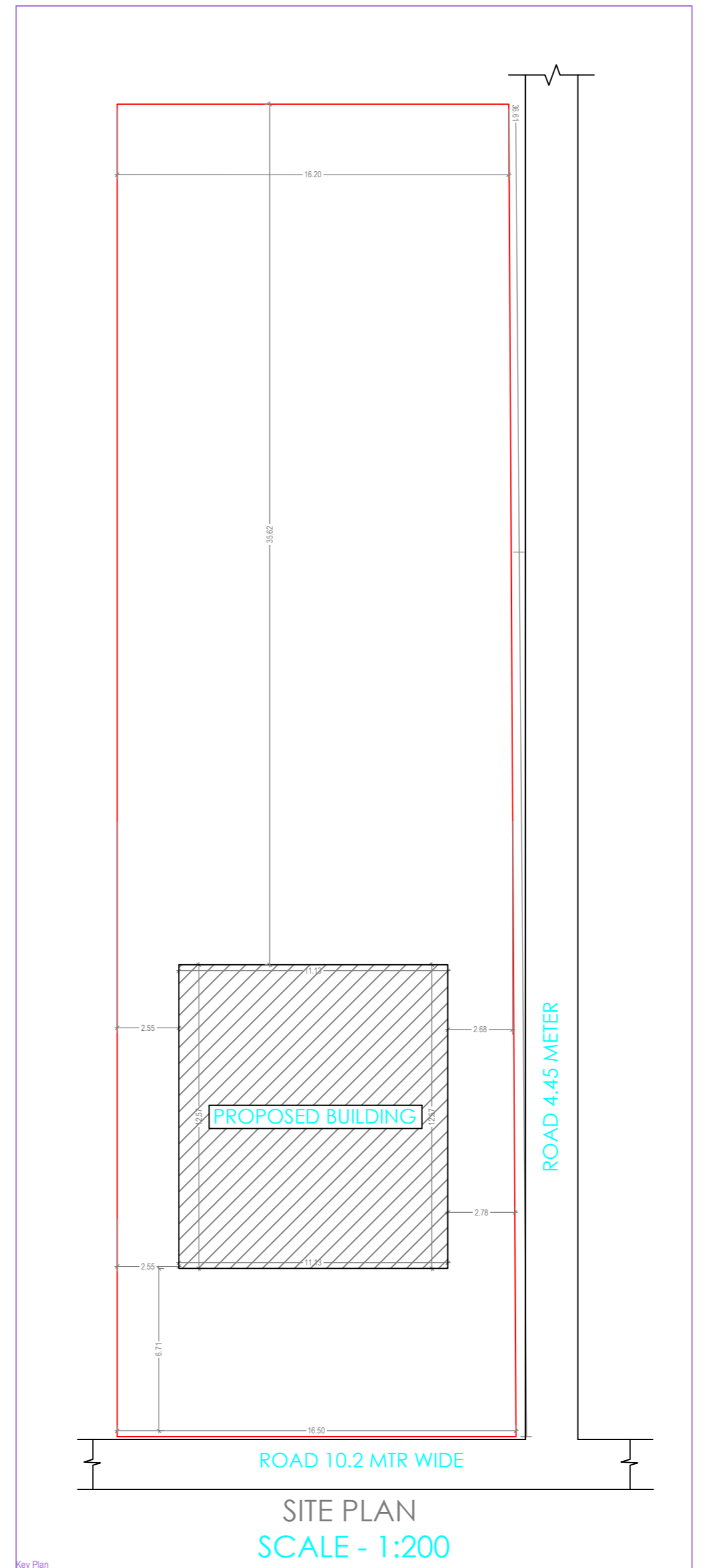
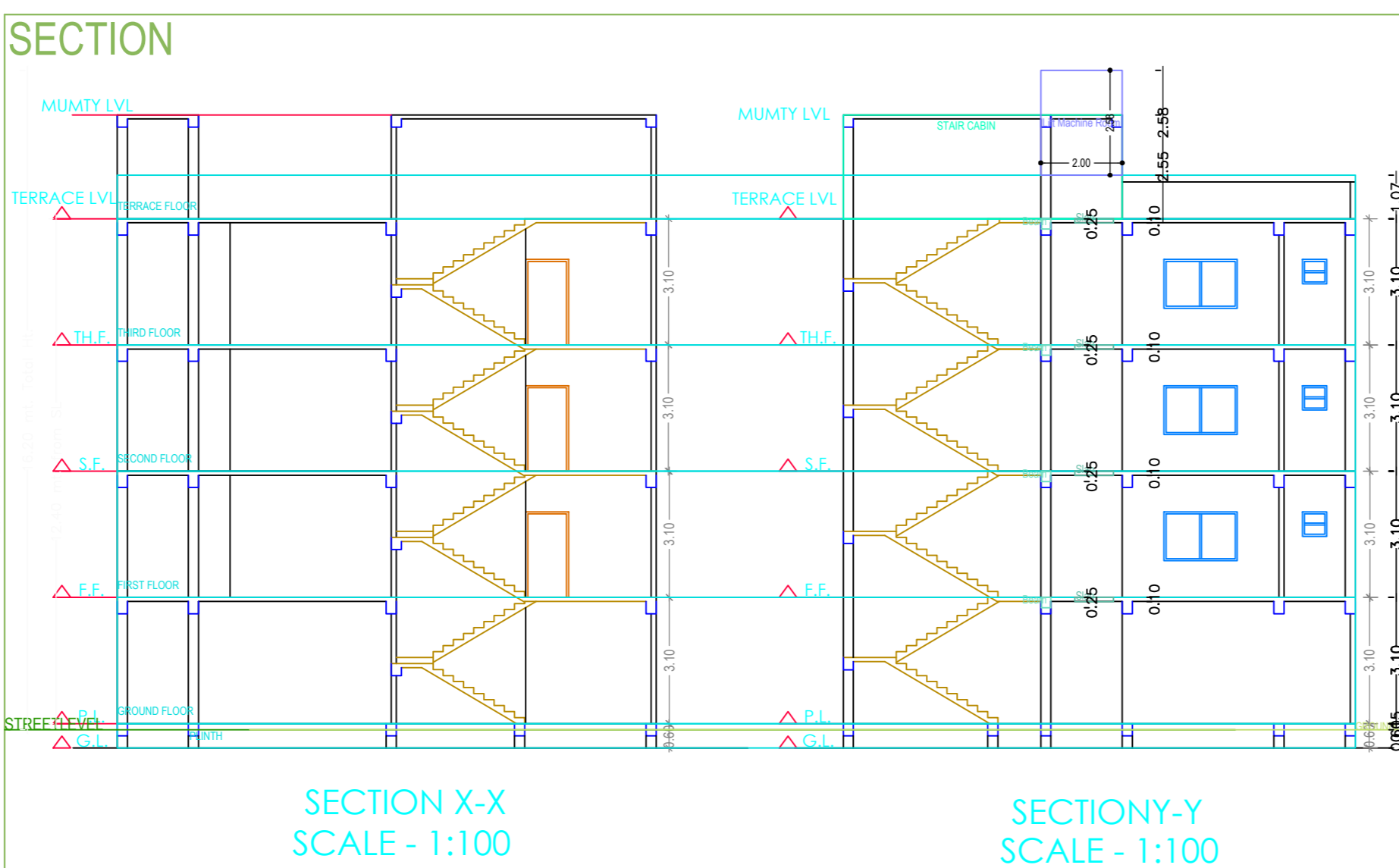
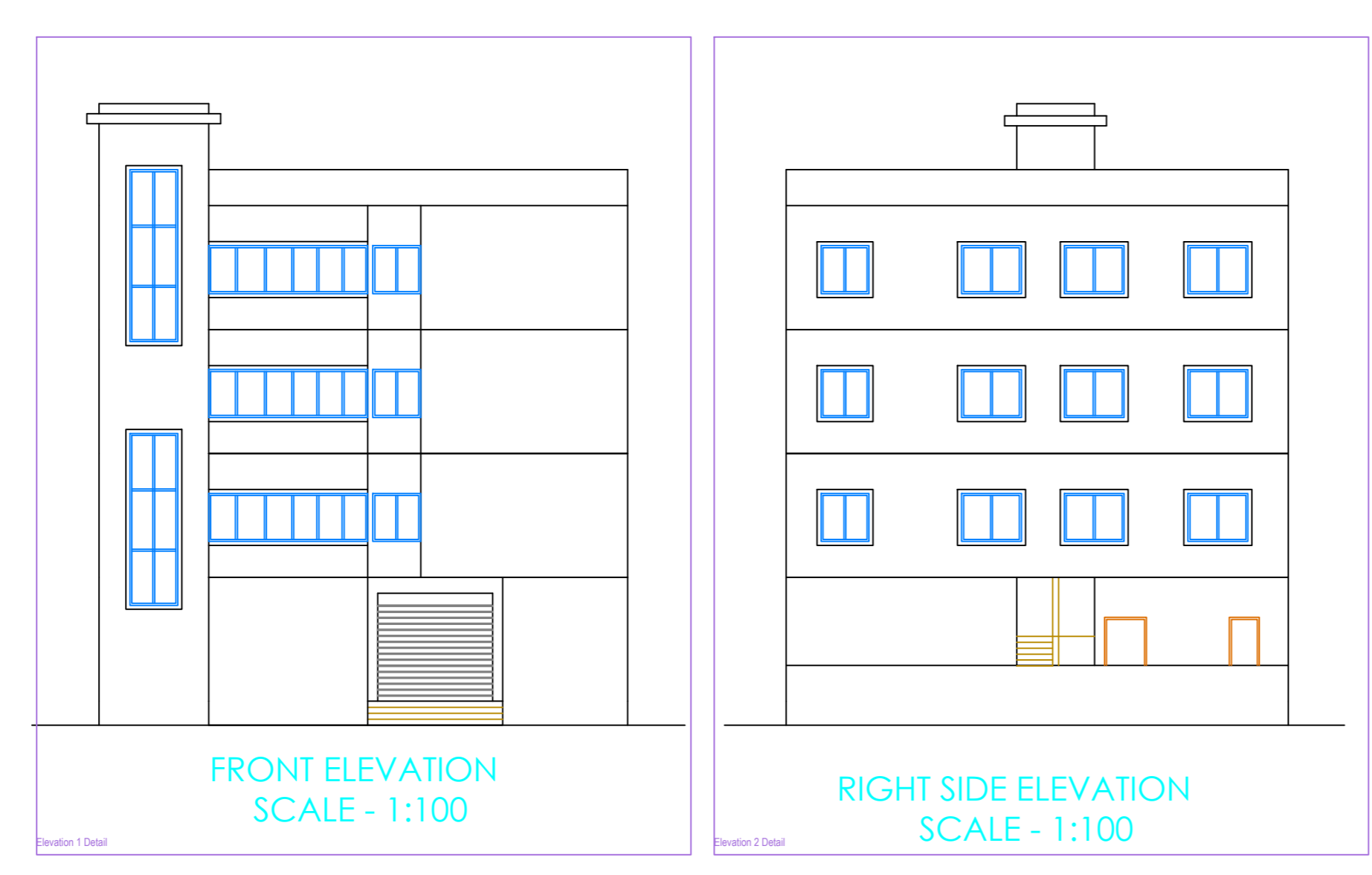
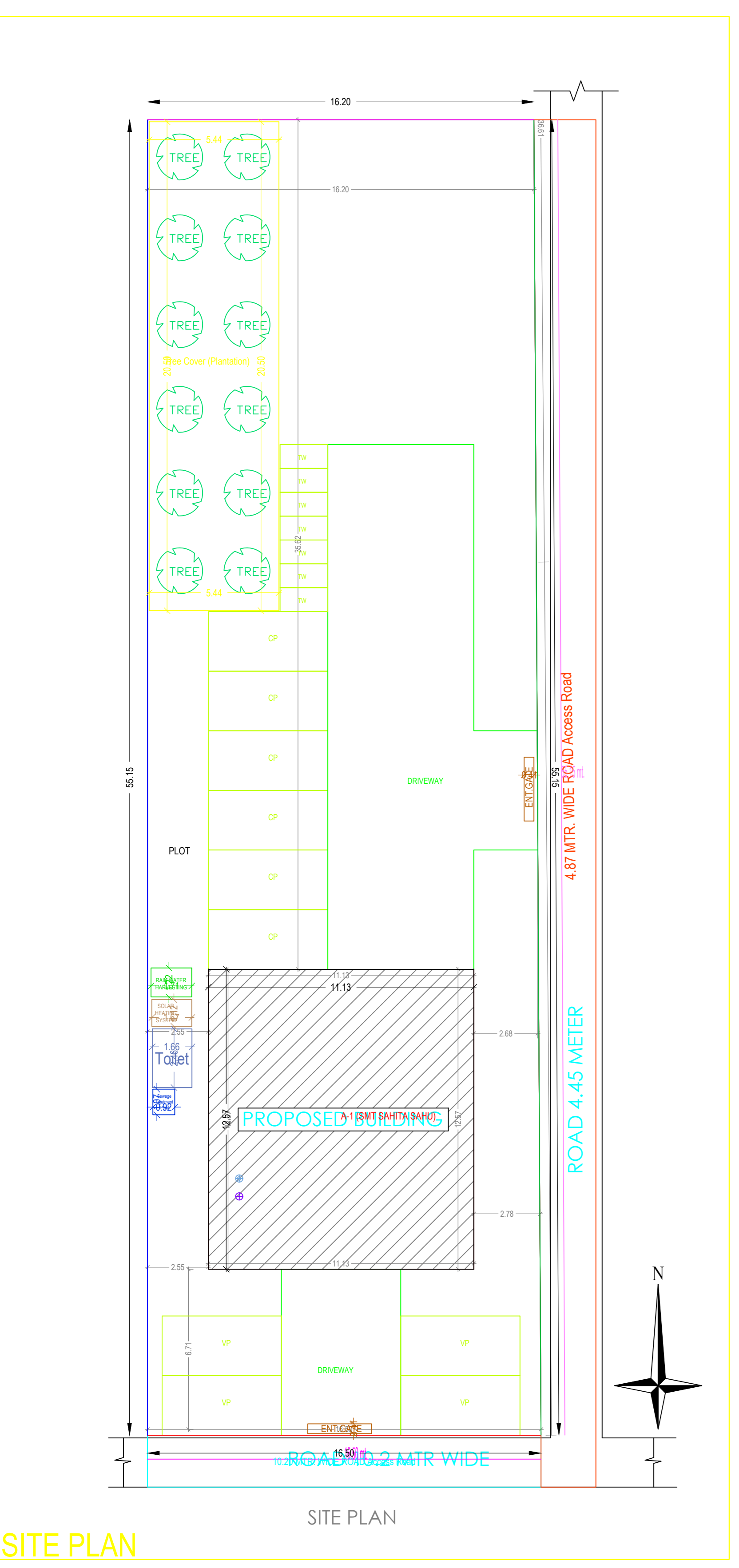

Building A (SMT SAHITA SAHU)

Item Name	Code	Quantity	Unit	Rate	Amount
Ground Floor	000	1.00	Sq.M	130.00	130.00
First Floor	100	1.00	Sq.M	130.00	130.00
Second Floor	200	1.00	Sq.M	130.00	130.00
Third Floor	300	1.00	Sq.M	130.00	130.00
Terrace	400	1.00	Sq.M	130.00	130.00
Total		5.00			650.00

SCHEDULE OF JOINERY:

Item Name	Code	Quantity	Unit	Rate	Amount
Window	01	10	Sq.M	100.00	1000.00
Door	02	5	Sq.M	200.00	1000.00

SCHEDULE OF JOINERY:

Item Name	Code	Quantity	Unit	Rate	Amount
Window	01	10	Sq.M	100.00	1000.00
Door	02	5	Sq.M	200.00	1000.00

UNBILU Table for Building A (SMT SAHITA SAHU)

FLOOR	Area	Volume	Weight	Value
GROUND FLOOR	130.00	130.00	130.00	130.00
FIRST FLOOR	130.00	130.00	130.00	130.00
SECOND FLOOR	130.00	130.00	130.00	130.00
THIRD FLOOR	130.00	130.00	130.00	130.00
TERRACE	130.00	130.00	130.00	130.00
Total	650.00	650.00	650.00	650.00

AREA INDEX

Category	Area (Sq.M)
Total Area	1650.00
Building Area	650.00
Parking Area	100.00
Open Area	900.00

PARKING CALCULATION:

Category	Area (Sq.M)	Capacity
Open Parking	100.00	10
Covered Parking	0.00	0
Total	100.00	10

MARGIN DETAIL:

Side	Width (M)
Front	3.00
Side	3.00
Back	3.00

FAIR & Tancement Details (Table 4c-1)

Item	Code	Quantity	Unit	Rate	Amount
Foundation	01	10	Sq.M	100.00	1000.00
Column	02	5	Sq.M	200.00	1000.00

FAIR & Tancement Details (Table 4c-1):

Item	Code	Quantity	Unit	Rate	Amount
Foundation	01	10	Sq.M	100.00	1000.00
Column	02	5	Sq.M	200.00	1000.00