

SITE PLAN

FAR & Tenement Details (Table 4c-1)

Building	No. of Same Bldg	Gross Built Up Area (Sq.mt.)	Deductions From Gross BUA/Area in Sq.mt. Cutout	Total Built Up Area (Sq.mt.)	Deductions (Area in Sq.mt.)		Proposed FAR Area (Sq.mt.)	Total FAR Area (Sq.mt.)	Total Consumed Additional FAR Area (Sq.mt.)	Tnmt (No.)
					Lift	Parking				
A (SMT SAHITA SAHU)	1	559.95	1.80	558.15	10.17	63.10	79.95	484.88	484.88	06
Grand Total	1	559.95	1.80	558.15	10.17	63.10	79.95	484.88	484.88	06

Proposal Basic Information

Proposal File No.	LNP/BI/0019/W05/2020
Owner Name	SAHITA SAHU
Khata No	75/2
Plot No	1128/869
Village Name	Katmu
Use	Mixed
SubUse	Resi+Comm

Required Parking (Table 7a)

Building Name	Type	SubUse	Area (Sq.mt.)	Units		Car		Visitors Car		TwoWheeler		
				Regd.	Prop.	Regd./Unit	Prop.	Regd./Unit	Prop.	Regd./Unit	Prop.	
A (SMT SAHITA SAHU)	Residential	Residential Apartment Bldg	>0	1	1.00	1	1	-	-	-	-	-
			>0	6	-	1	1	-	-	-	-	-
			>0	1	-	1	0.2	-	-	-	-	-
			>0	1	-	-	-	-	-	-	1	-
			>0	1	-	1	0.5	-	-	-	-	-
			>0	1	-	-	-	-	-	-	1	0.5
			>0	1	1.00	-	-	-	-	-	1	1
			>0	1	1.00	-	-	-	1	1	-	-
			>0	6	-	-	-	1	1	-	-	-
			>0	1	-	-	-	1	1	-	-	-
Total	-	-	-	-	3	8	-	3	0	-	2	

Parking Check (Table 7b)

Vehicle Type	Reqd.		Prop.	
	No.	Area	No.	Area
Car	-	-	4	50.00
Two Stack Car	-	-	4	50.00
Total Car	3	37.50	8	100.00
Total Visitor Parking	3	37.50	3	40.50
Parallel Visitor's Car Parking	-	-	3	40.50
TwoWheeler	-	-	10	20.00
Total TwoWheeler	2	4.00	10	20.00
Other Parking	-	-	-	63.10
Total	-	79.00	-	243.60

AREA STATEMENT LOHARDAGA NAGAR PARISHAD	VERSION NO.: 1.0.49 VERSION DATE: 22/06/2020
PROJECT DETAIL:	
Region: JHARKHAND URBAN LOCAL BODIES	Plot Use: Mixed
District: LOHARDAGA	Plot SubUse: Resi+Comm
Authority: LOHARDAGA NAGAR PARISHAD	PlotNearbyReligiousStructure: NA
Inward No: LNP/BI/0019/W05/2020	PlotSubPlot No: 1128/869
Application Type: General Proposal	North: Plot No. - 869
Project Type: Building Permission	South: Road Width - 10.2
Nature of Development: New	East: Road Width - 4.57
Location of Development Area: Old Area	West: Plot No. - 866
AREA DETAILS:	SQ.MT.
AREA OF PLOT (Minimum)	(A) 405.90
NET AREA OF PLOT(Gross Plot Area - Deduction from Gross Plot area)	(A-Deductions) 405.90
Deduction for Balance Plot Area(from Gross Plot Area)	
Common Plot	51.06
Total	51.06
BALANCE AREA OF PLOT(Net Plot Area - Recreational/Amenity space)	(A-Deductions) 354.84
PLOT AREA FOR COVERAGE(Net Plot Area)	(A-Deductions) 405.90
Plot Area for FAR (Net Plot Area + Road Widening Area)	(A-Deductions) 405.90
COVERAGE CHECK	
Permissible Coverage area (60.00 %)	243.54
Proposed Coverage Area (34.49 %)	139.98
Total Prop. Coverage Area (34.49 %)	139.98
Balance coverage area (25.51 %)	103.56
FAR CHECK	
Perm. FAR Area (2.00)	811.80
Total Perm. FAR area	811.80
Residential FAR	79.95
Commercial FAR	404.93
Proposed FAR Area	484.88
Total Proposed FAR Area	484.88
Consumed FAR (Factor)	1.19
Balance FAR Area	326.92
BUILT UP AREA CHECK	
Total Proposed BuiltUp Area	558.15
ARCHITECT (Regd)	ASHWINI KUMAR SAHU
ENGINEER (Regd)	
SUPERVISOR (Regd)	
OWNER (Regd)	SAHITA SAHU
DEVELOPMENT AUTHORITY	LOCAL BODY

COLOR INDEX	
PLOT BOUNDARY	Black
ABUTTING ROAD	Green
PROPOSED CONSTRUCTION	Red
COMMON PLOT	Yellow
ROAD WIDENING AREA	Blue
EXISTING (To be retained)	Light Blue
EXISTING (To be demolished)	Light Yellow

Buildingwise Floor FAR Details

Floor Name	Building Name A (SMT SAHITA SAHU)		Total	
	Proposed Built Up Area (Sq.mt.)	Proposed FAR Area (Sq.mt.)	Total Proposed Built Up Area (Sq.mt.)	Total FAR Area (Sq.mt.)
Ground Floor	139.98	76.88	139.98	76.88
First Floor	138.19	134.80	138.19	134.80
Second Floor	139.99	136.60	139.99	136.60
Third Floor	139.99	136.60	139.99	136.60
Terrace Floor	0.00	0.00	0.00	0.00
Total :	558.15	484.88	558.15	484.88

Building USE/SUBUSE Details

Building Name	Building Use	Building SubUse	Building Structure
A (SMT SAHITA SAHU)	Residential	Residential Bldg/Apartment	Non-Highrise

LTP NAME AND SIGNATURE	STRUCTURAL ENG'S NAME AND SIGNATURE	BUILDER NAME AND SIGNATURE	DIGITAL SIGNATURE
ASHWINI KUMAR SAHU LNP/ENG/0005/2017			

Proposal Basic Information	
Proposal File No.	LNP/BP/0019/W05/2020
Owner Name	SAHITA SAHU
Khata No	75/2
Plot No	1128/869
Village Name	Katmu
Use	Mixed
SubUse	Resi+Comm

SITE PLAN
SCALE - 1:200

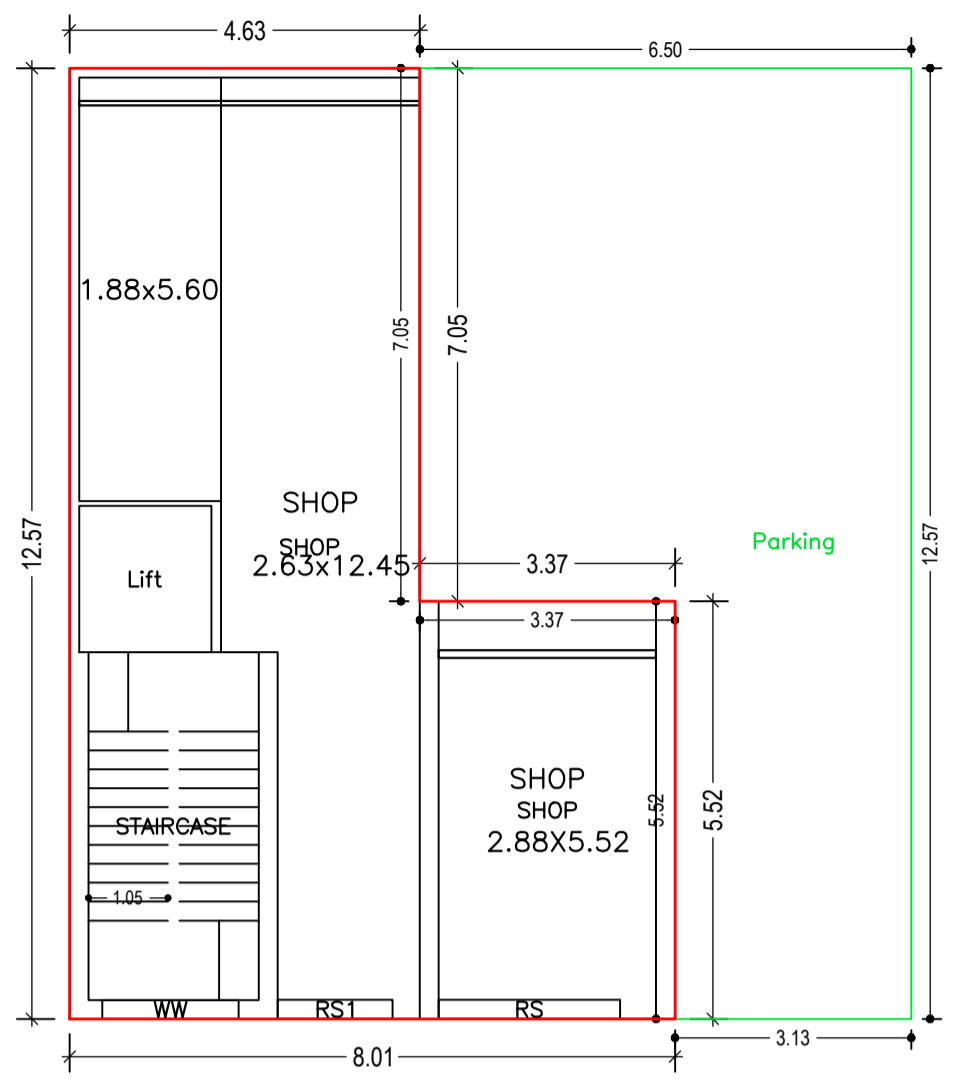

GROUND FLOOR PLAN
(Proposed)
SCALE 1:100

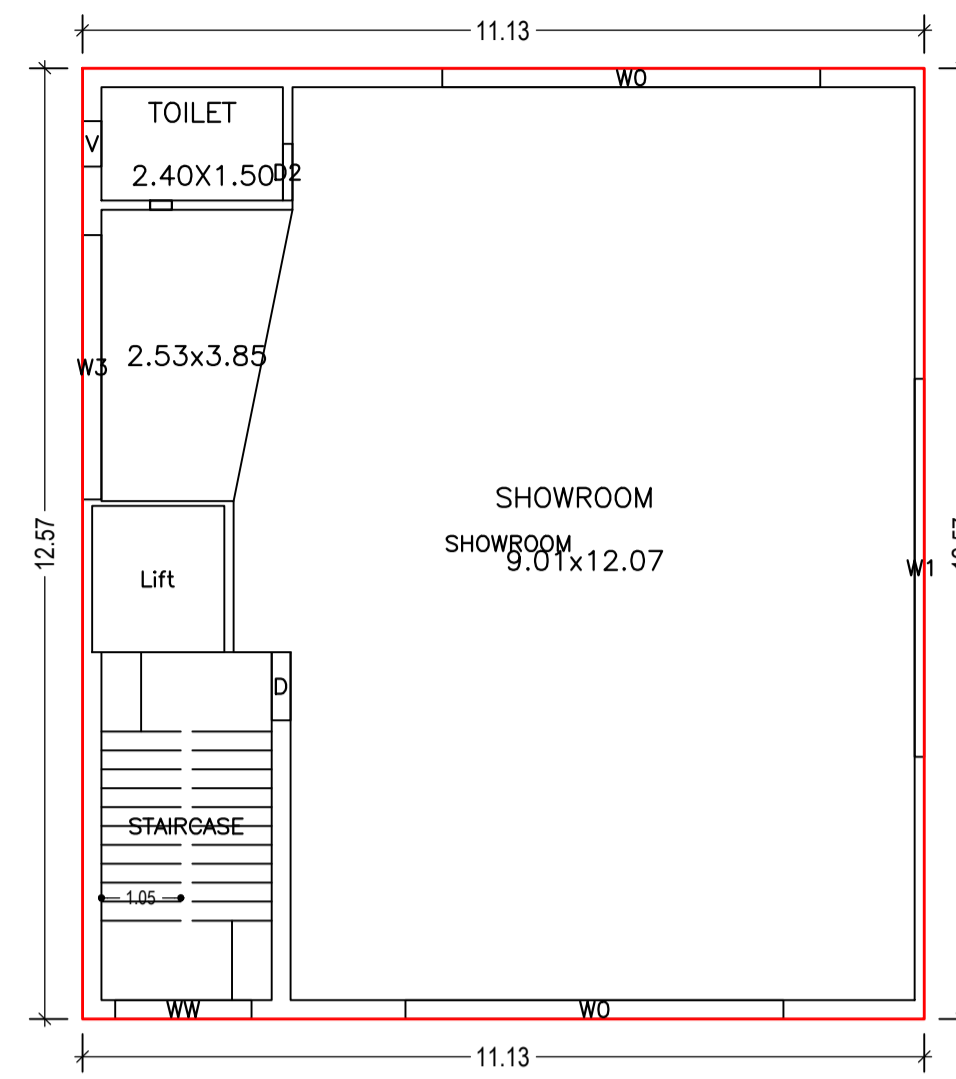

SECOND FLOOR PLAN
(Proposed)
SCALE 1:100

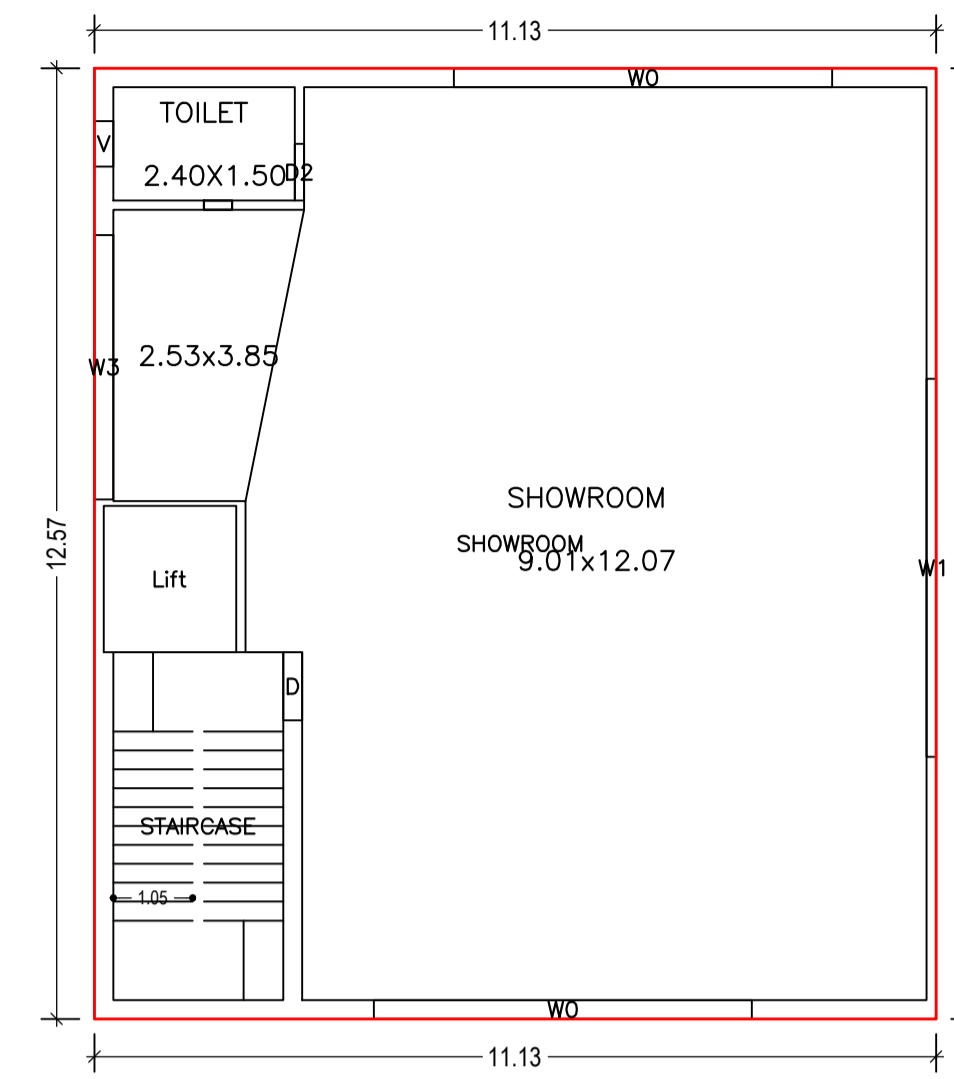

THIRD FLOOR PLAN
(Proposed)
SCALE 1:100

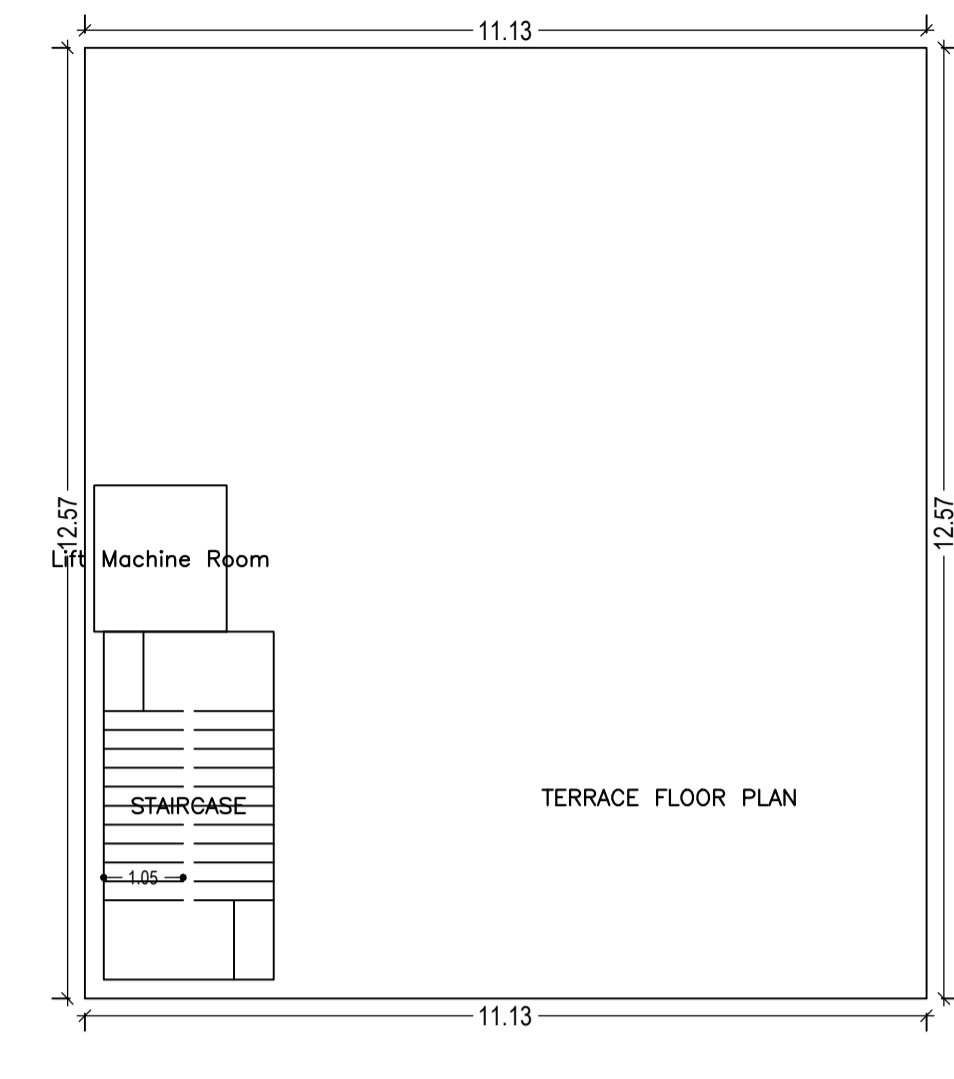

TERRACE FLOOR PLAN
(SCALE 1:100)

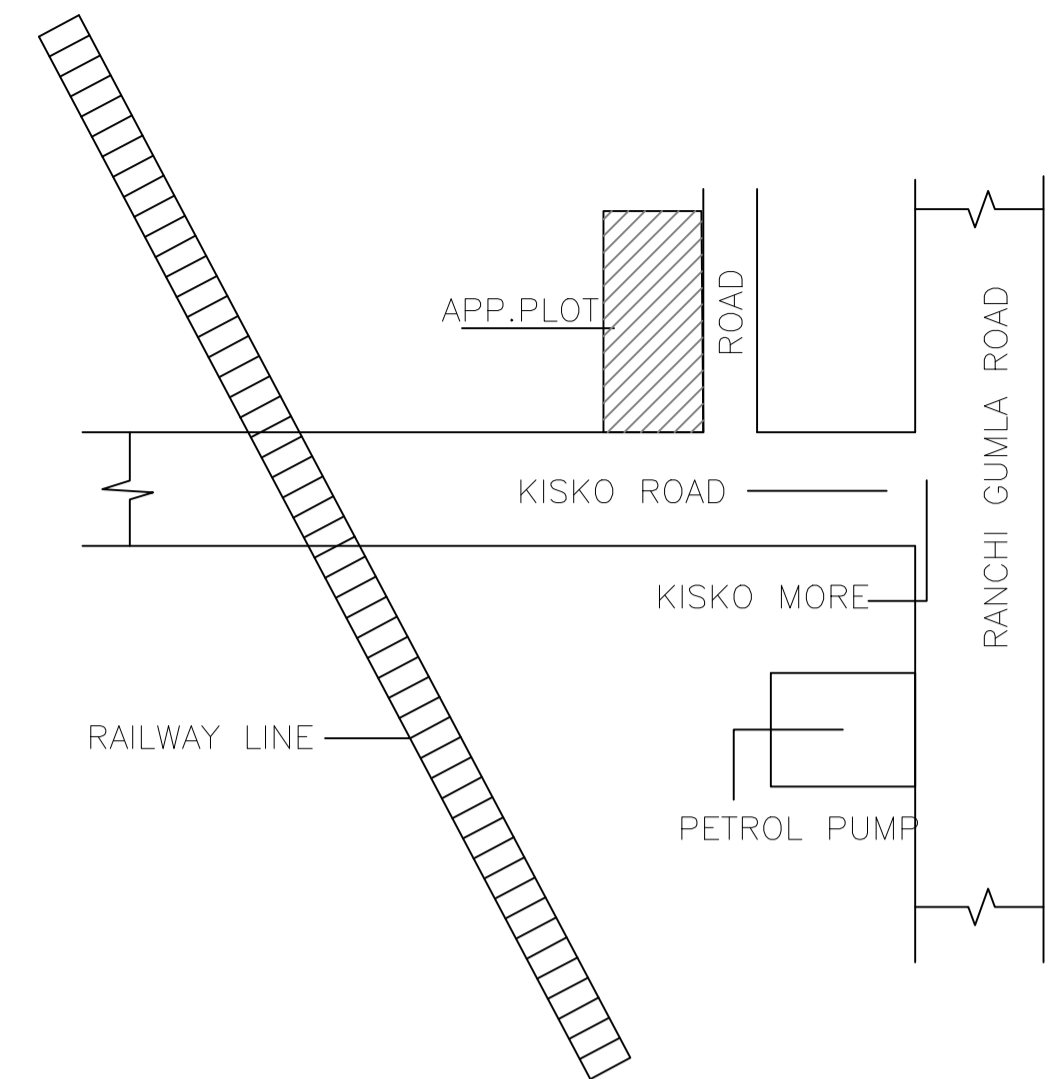

LOCATION PLAN
SCALE - NTS

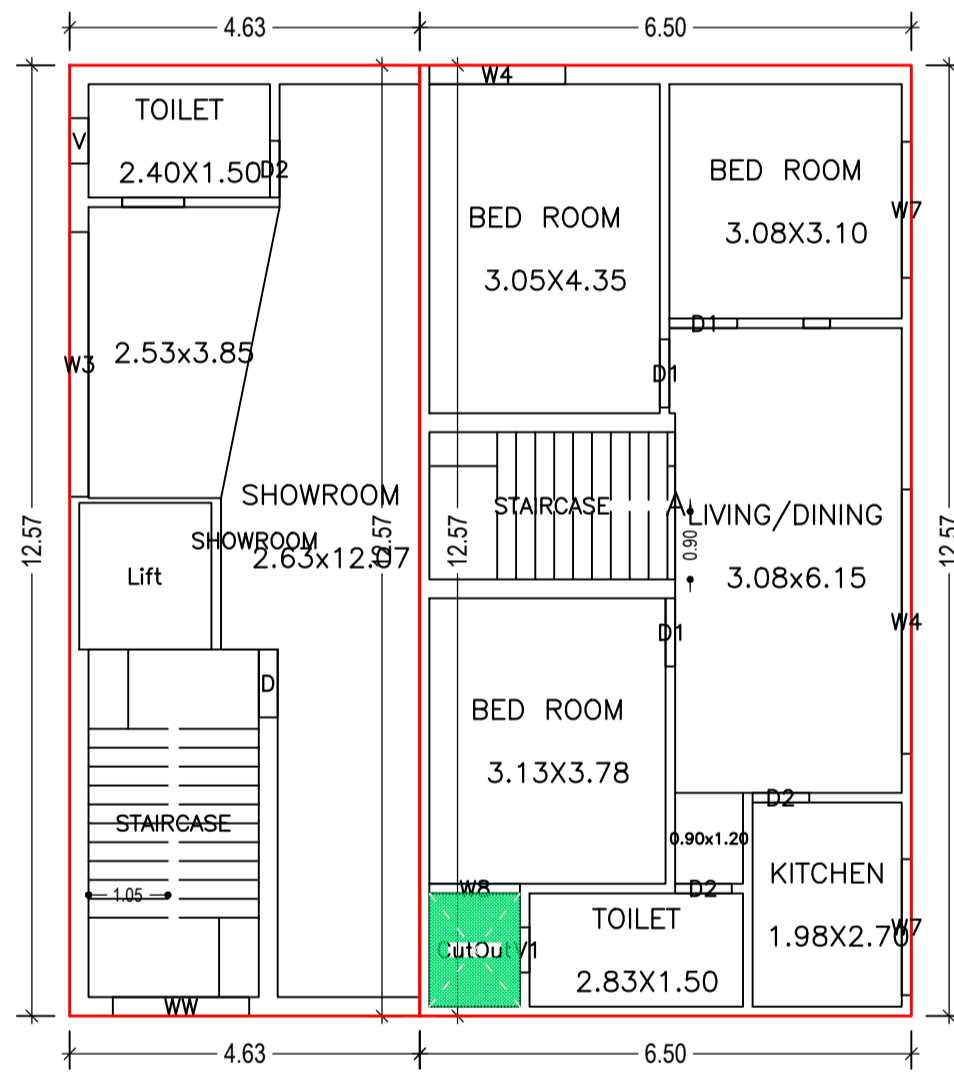

FIRST FLOOR PLAN
(Proposed)
SCALE 1:100

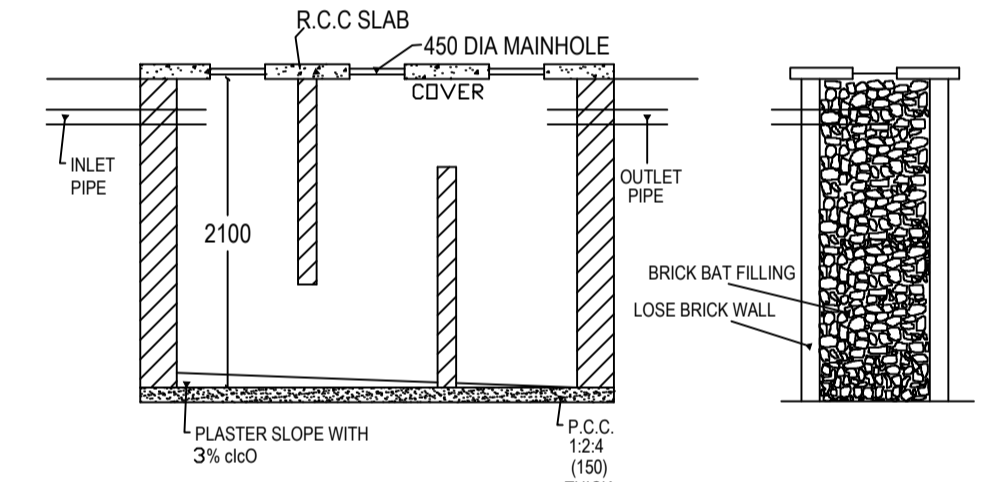

SECTION N-N.

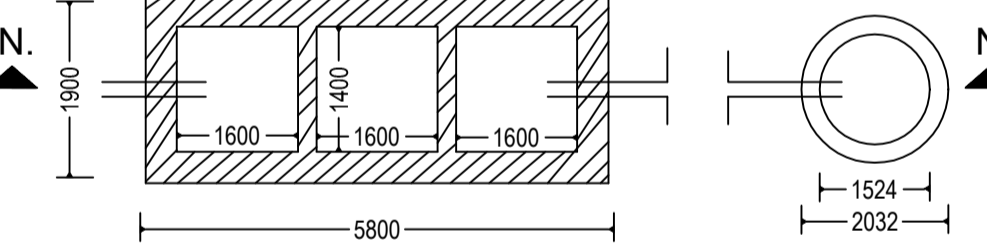

DETAIL OF SEPTIC TANK & SOAKPIT.

SCHEDULE OF DOOR:

BUILDING NAME	NAME	LENGTH	HEIGHT	NOS
A (SMT SAHITA SAHU)	D2	0.75	2.13	05
A (SMT SAHITA SAHU)	D1	0.90	2.13	03
A (SMT SAHITA SAHU)	D	0.90	2.13	03
A (SMT SAHITA SAHU)	RS1	1.52	2.13	01
A (SMT SAHITA SAHU)	RS	2.40	2.13	01

SCHEDULE OF WINDOW/VENTILATION:

BUILDING NAME	NAME	LENGTH	HEIGHT	NOS
A (SMT SAHITA SAHU)	V1	0.60	2.70	01
A (SMT SAHITA SAHU)	V	0.60	2.70	03
A (SMT SAHITA SAHU)	W8	1.20	2.70	01
A (SMT SAHITA SAHU)	W7	1.80	2.70	02
A (SMT SAHITA SAHU)	W4	1.80	2.70	01
A (SMT SAHITA SAHU)	WW	1.80	2.70	03
A (SMT SAHITA SAHU)	W4	3.50	2.70	01
A (SMT SAHITA SAHU)	W3	3.50	2.70	03
A (SMT SAHITA SAHU)	W0	5.00	2.70	04
A (SMT SAHITA SAHU)	W1	5.00	2.70	02

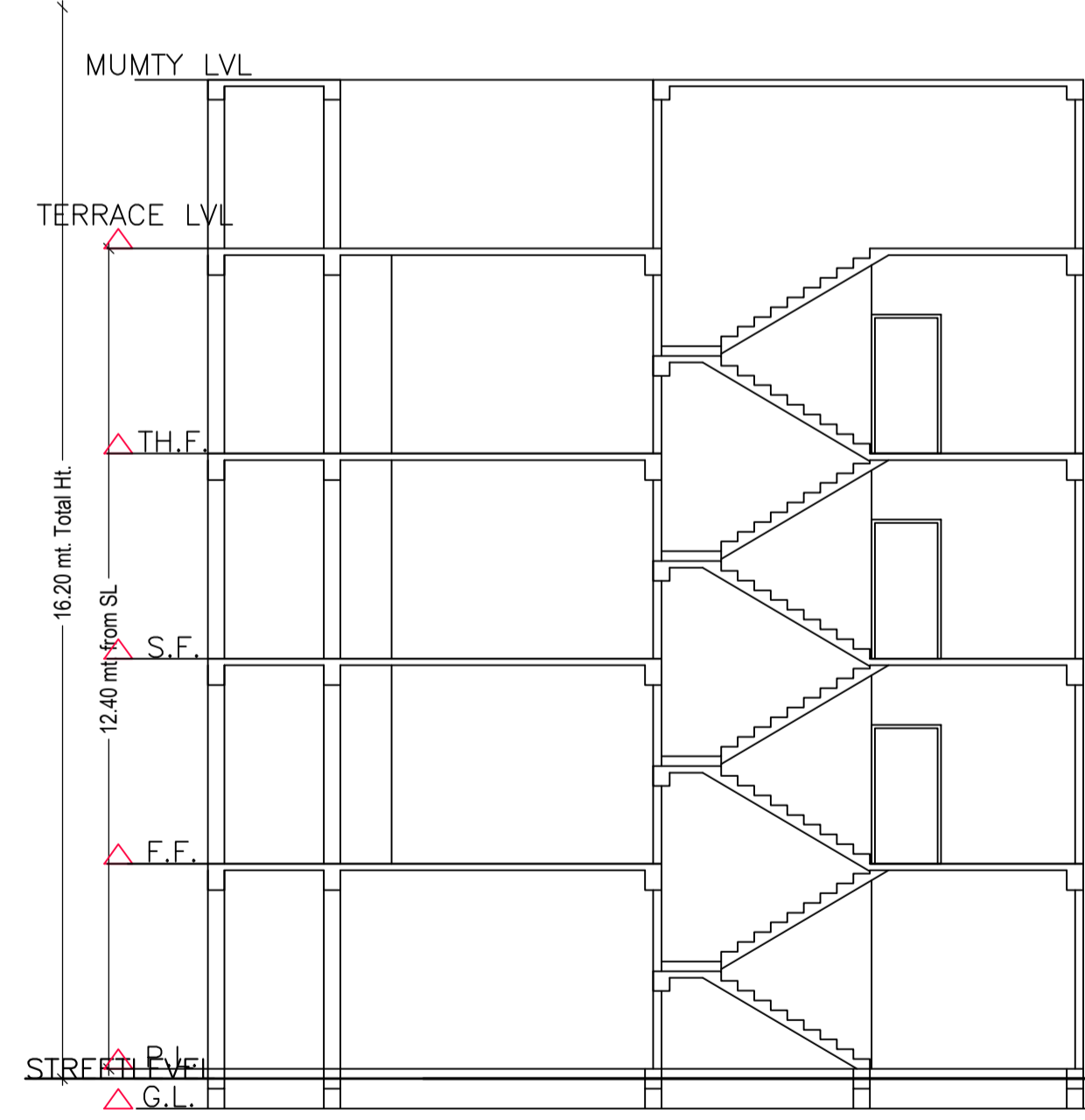

SECTION X-X
SCALE - 1:100

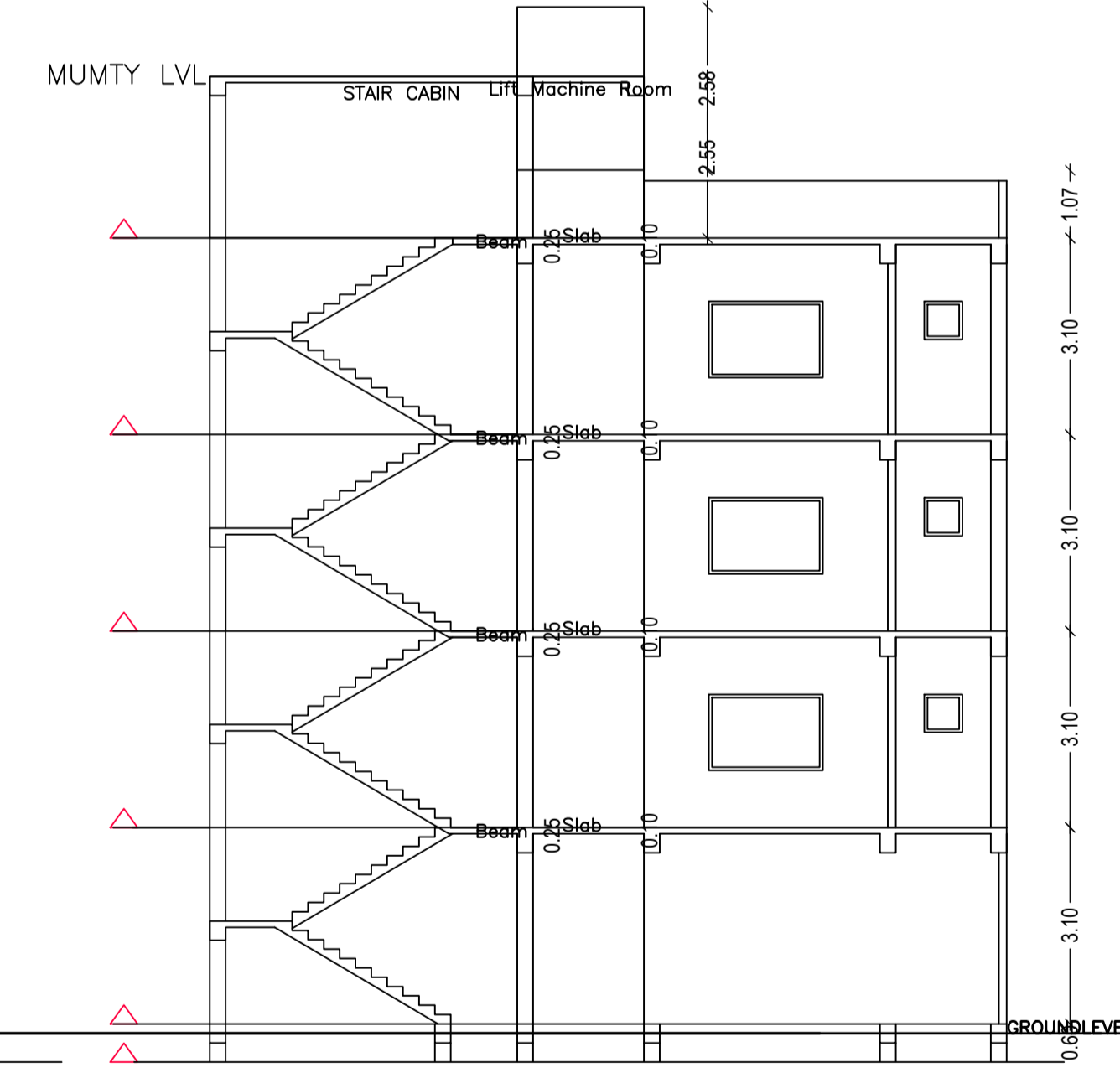

SECTION Y-Y
SCALE - 1:100

UnitBUA Table for Building :A (SMT SAHITA SAHU)

FLOOR	Name	UnitBUA Type	UnitBUA Area	Carpet Area	No. of Rooms	No. of Tenement
GROUND FLOOR PLAN	SHOP	OFFICE	15.88	15.60	1	2
	SHOP	OFFICE	39.62	39.36	1	
FIRST FLOOR PLAN	A	FLAT	66.14	66.10	6	2
	SHOWROOM	OFFICE	37.90	37.80	2	
SECOND FLOOR PLAN	SHOWROOM	OFFICE	114.89	114.85	2	1
	SHOWROOM	OFFICE	114.89	114.84	2	
Total:			389.33	388.54	14	6

Building :A (SMT SAHITA SAHU)

Floor Name	Gross Builtup Area	Deductions From Gross BUA(Area in Sq.mt.)		Total Built Up Area (Sq.mt.)	Deductions (Area in Sq.mt.)		Proposed FAR Area (Sq.mt.)	Total FAR Area (Sq.mt.)	Total Consumed Additional FAR Area (Sq.mt.)	Trmt (No.)
		Cutout	Area		Lift	Parking				
Ground Floor	139.98	0.00	139.98	0.00	63.10	0.00	76.88	76.88	0.00	02
First Floor	139.99	1.80	138.19	3.39	0.00	0.00	79.95	134.80	134.80	02
Second Floor	139.99	0.00	139.99	3.39	0.00	0.00	136.60	136.60	0.00	01
Third Floor	139.99	0.00	139.99	3.39	0.00	0.00	136.60	136.60	0.00	01
Terrace Floor	0.00	0.00	0.00	0.00	0.00	0.00	0.00	0.00	0.00	00
Total:	559.95	1.80	558.15	10.17	63.10	0.00	79.95	484.88	484.88	06
Total Number of Same Buildings	1									
Total:	559.95	1.80	558.15	10.17	63.10	0.00	79.95	484.88	484.88	06

LTP NAME AND SIGNATURE	STRUCTURAL ENG'S NAME AND SIGNATURE	BUILDER NAME AND SIGNATURE	DIGITAL SIGNATURE
ASHWINI KUMAR SAHU LNP/ENG/0005/2017			

Proposal Basic Information	
Proposal File No.	LNP/BI/0019/W05/2020
Owner Name	SAHITA SAHU
Khata No	75/2
Plot No	1128/869
Village Name	Katmu
Use	Mixed
SubUse	Resi+Comm

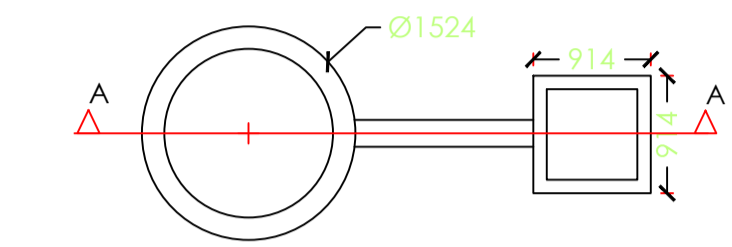

DETAIL OF GROUND WATER RECHAREGING PIT WITH SLIT TANK

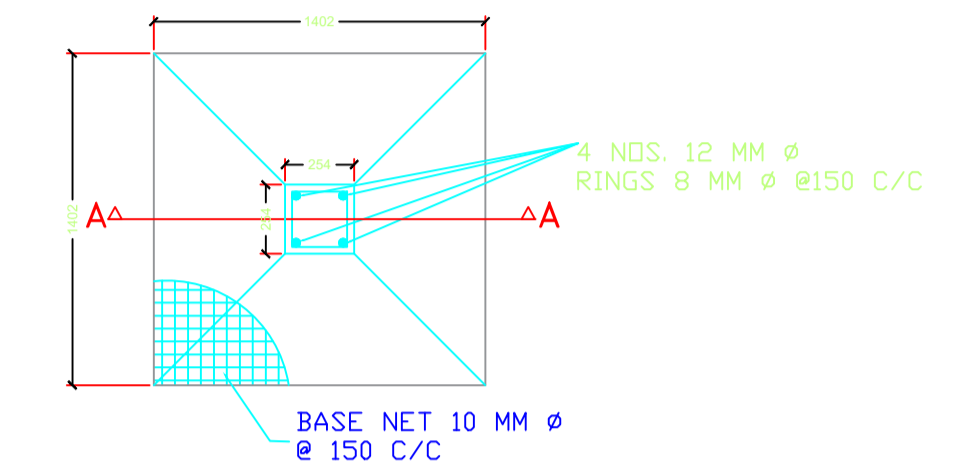

PLAN OF COLUMN FOUNDATION
SCALE= 1:50

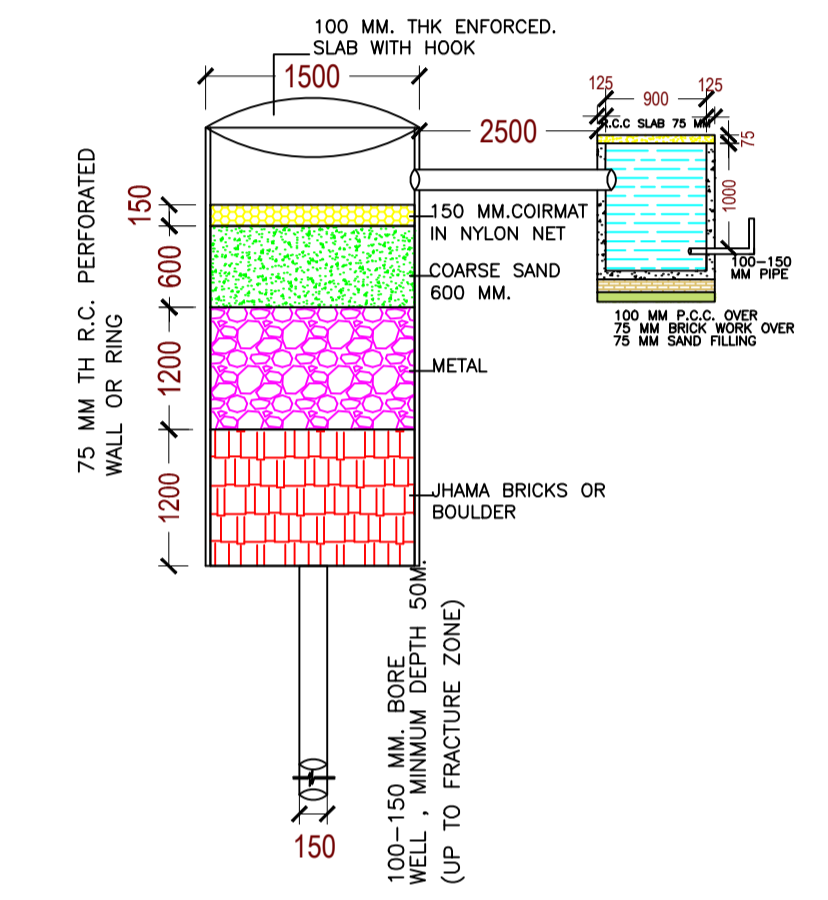

SECTION AT A-A (SCALE 1:50)

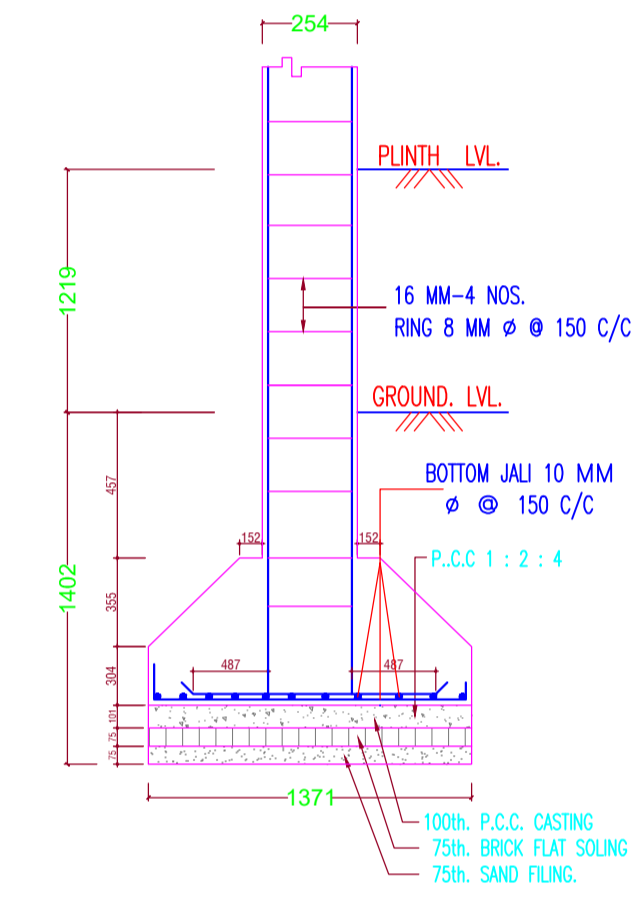

SECTION ON A-A
SCALE= 1:50

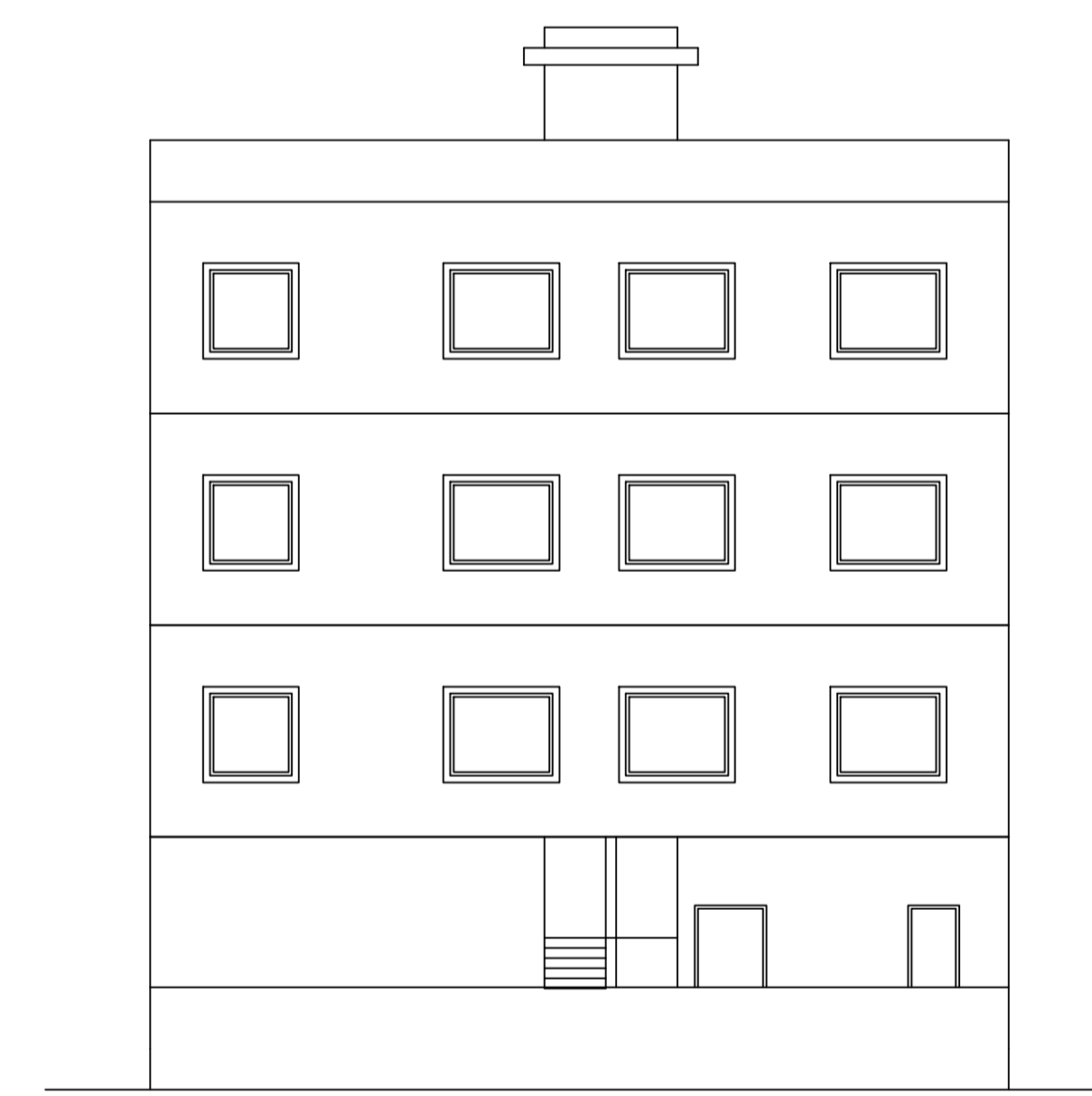

RIGHT SIDE ELEVATION
SCALE - 1:100

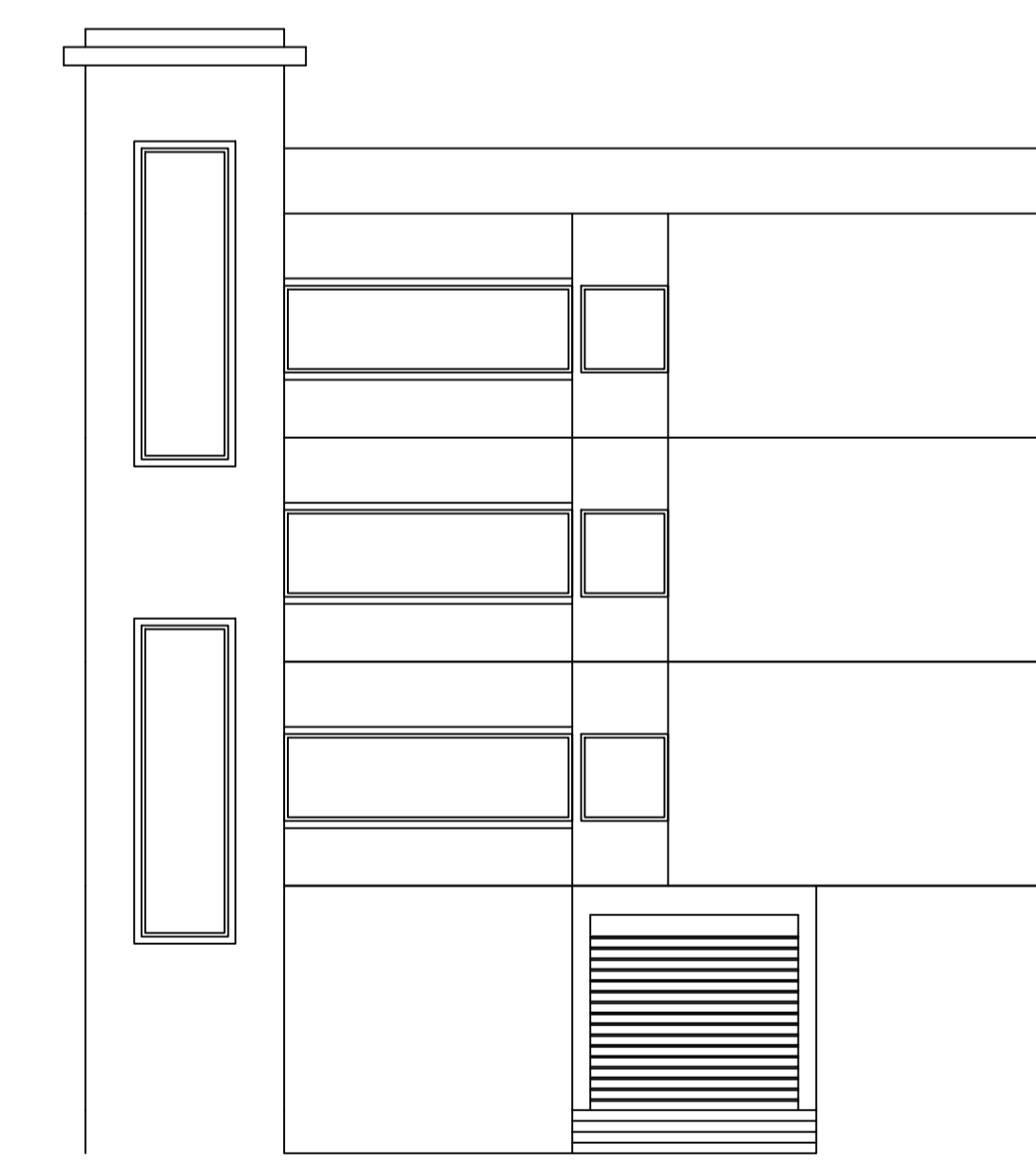

FRONT ELEVATION
SCALE - 1:100

LTP NAME AND SIGNATURE	STRUCTURAL ENG'S NAME AND SIGNATURE	BUILDER NAME AND SIGNATURE	DIGITAL SIGNATURE
ASHWINI KUMAR SAHU LNP/ENG/0005/2017			