

SITE PLAN

FAR & Tenement Details (Table 4c-1)

Building	No. of Same Bldg	Total Built Up Area (Sq.mt.)	Deductions (Area in Sq.mt.)		Proposed FAR Area (Sq.mt.)	Total FAR Area (Sq.mt.)	Total Consumed Additional FAR Area (Sq.mt.)	Trmnt (No.)
			Accessory Use	Resi.				
A (AMIYA KERKETTA)	1	210.76	18.64		192.12	192.12	192.12	01
Grand Total :	1	210.76	18.64		192.12	192.12	192.12	01

Proposal Basic Information

Proposal File No.	LNP/IBP/0029/W14/2020
Owner Name	AMIYA KERKETTA
Khata No	398, 305
Plot No	581,579
Village Name	Lohardaga
Use	Residential
SubUse	Bungalow/ Dwelling / Non Apartment

AREA STATEMENT	LOHARDAGA NAGAR PARISHAD	VERSION NO. : 1.0.49	VERSION DATE: 22/06/2020
PROJECT DETAIL:			
Region: JHARKHAND URBAN LOCAL BODIES	Plot Use: Residential		
District: LOHARDAGA	Plot SubUse: Bungalow/ Dwelling / Non Apartment		
Authority: LOHARDAGA NAGAR PARISHAD	Plot/Nearby/Religious/Structure: NA		
Inward No: LNP/IBP/0029/W14/2020	Plot/SubPlot No: 581,579		
Application Type: General Proposal	North: Plot No. - 577,580		
Project Type: Building Permission	South: Road Width - 3		
Nature of Development: New	East: Road Width - 3		
Location of Development Area: Old Area	West: Plot No. - 578		
AREA DETAILS:			
AREA OF PLOT (Minimum)	(A)		SQ.MT. 465.69
Deduction for NetPlot Area			
Surrender Free of Cost			39.71
Total			39.71
NET AREA OF PLOT(Gross Plot Area - Deduction from Gross Plot area)	(A-Deductions)		425.98
Deduction for Balance Plot Area(from Gross Plot Area)			
Surrender Free of Cost			39.71
Common Plot			44.99
Total			84.71
BALANCE AREA OF PLOT(Net Plot Area - Recreational/Amenity space)	(A-Deductions)		380.98
PLOT AREA FOR COVERAGE(Net Plot Area)	(A-Deductions)		425.98
Plot Area for FAR (Net Plot Area + Road Widening Area)	(A-Deductions)		465.69
COVERAGE CHECK			
Permissible Coverage area (60.00 %)			255.59
Proposed Coverage Area (24.74 %)			105.38
Total Prop. Coverage Area (24.74 %)			105.38
Balance coverage area (35.26 %)			150.21
FAR CHECK			
Perm. FAR Area (1.20)			558.83
Total Perm. FAR area			558.83
Residential FAR			192.11
Proposed FAR Area			192.11
Total Proposed FAR Area			192.11
Consumed FAR (Factor)			0.41
Balance FAR Area			366.72
BUILT UP AREA CHECK			
Total Proposed BuiltUp Area			210.76
ARCHITECT (Regd)		ASHWINI KUMAR SAHU	
ENGINEER (Regd)			
SUPERVISOR (Regd)			
OWNER (Regd)		AMIYA KERKETTA	
DEVELOPMENT AUTHORITY		LOCAL BODY	

COLOR INDEX	
PLOT BOUNDARY	Black
ABUTTING ROAD	Green
PROPOSED CONSTRUCTION	Red
COMMON PLOT	Yellow
ROAD WIDENING AREA	Blue
EXISTING (To be retained)	Blue
EXISTING (To be demolished)	Yellow

Buildingwise Floor FAR Details

Floor Name	Building Name		Total	
	Proposed Built Up Area (Sq.mt.)	Proposed FAR Area (Sq.mt.)	Total Proposed Built Up Area (Sq.mt.)	Total FAR Area (Sq.mt.)
Ground Floor	105.38	96.06	105.38	96.06
First Floor	105.38	96.06	105.38	96.06
Terrace Floor	0.00	0.00	0.00	0.00
Total :	210.76	192.12	210.76	192.12

Building USE/SUBUSE Details

Building Name	Building Use	Building SubUse	Building Structure
A (AMIYA KERKETTA)	Residential	Bungalow/ Dwelling / Non Apartment	Non-Highrise

LTP NAME AND SIGNATURE	STRUCTURAL ENG'S NAME AND SIGNATURE	BUILDER NAME AND SIGNATURE	DIGITAL SIGNATURE
ASHWINI KUMAR SAHU LNP/ENG/0005/2017			

Proposal Basic Information	
Proposal File No.	LNP/EP/0029/W14/2020
Owner Name	AMIYA KERKETTA
Khata No	398, 305
Plot No	581,579
Village Name	Lohardaga
Use	Residential
SubUse	Bungalow/ Dwelling / Non Apartment

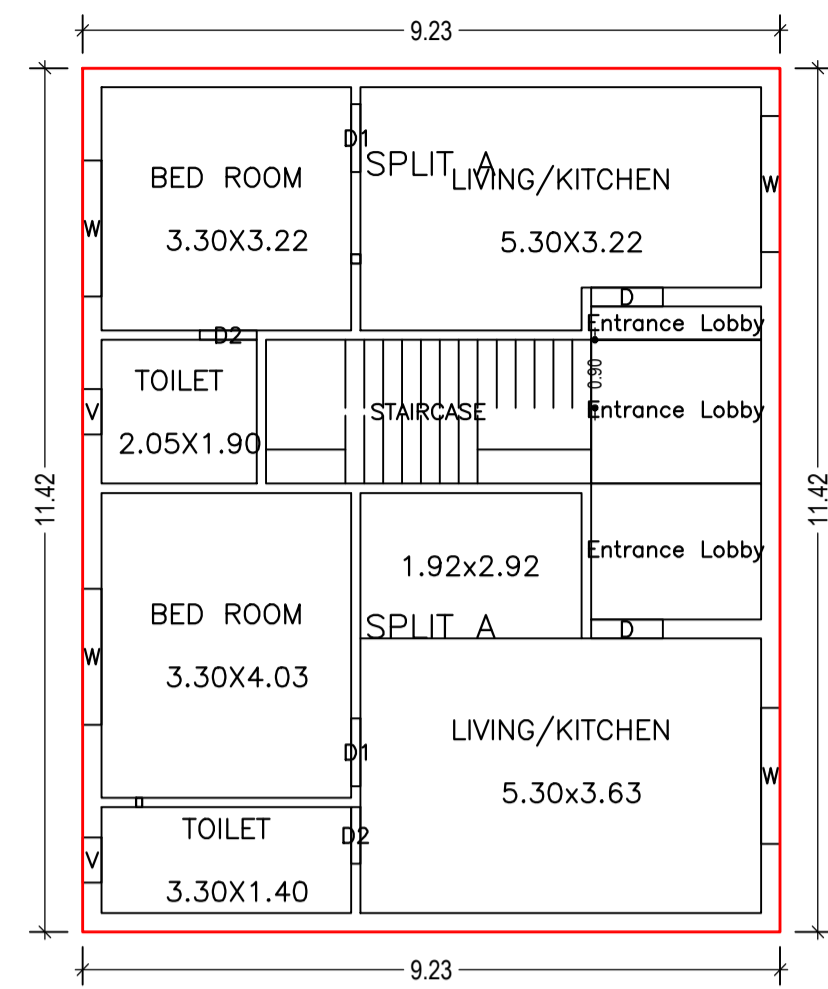

GROUND FLOOR PLAN (Proposed) (SCALE 1:100)

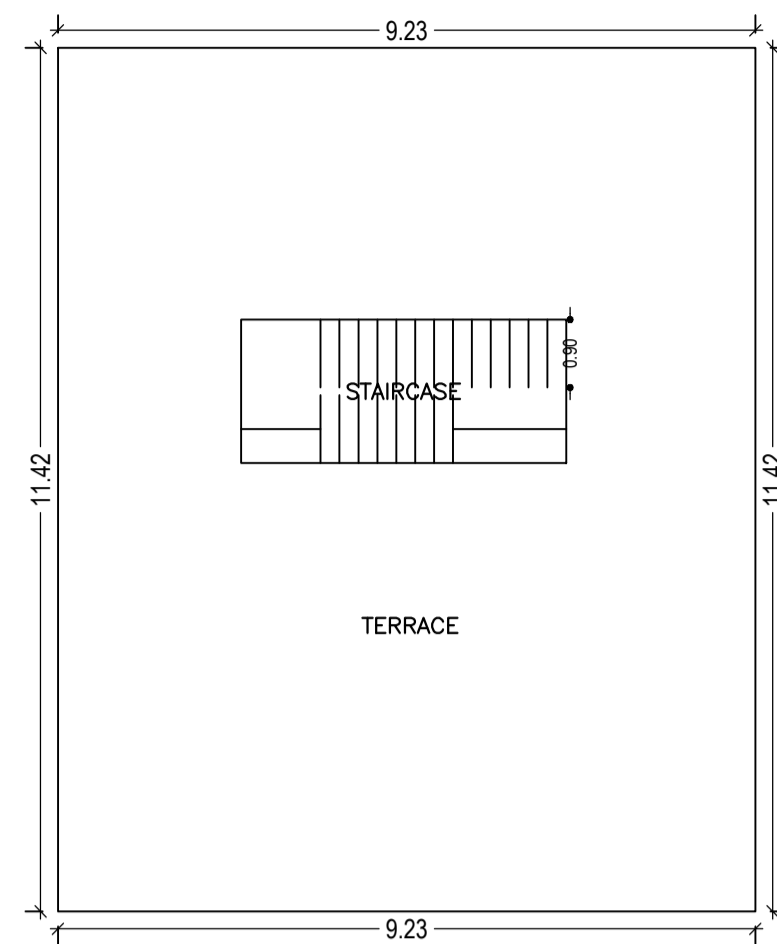

TERRACE FLOOR PLAN (SCALE 1:100)

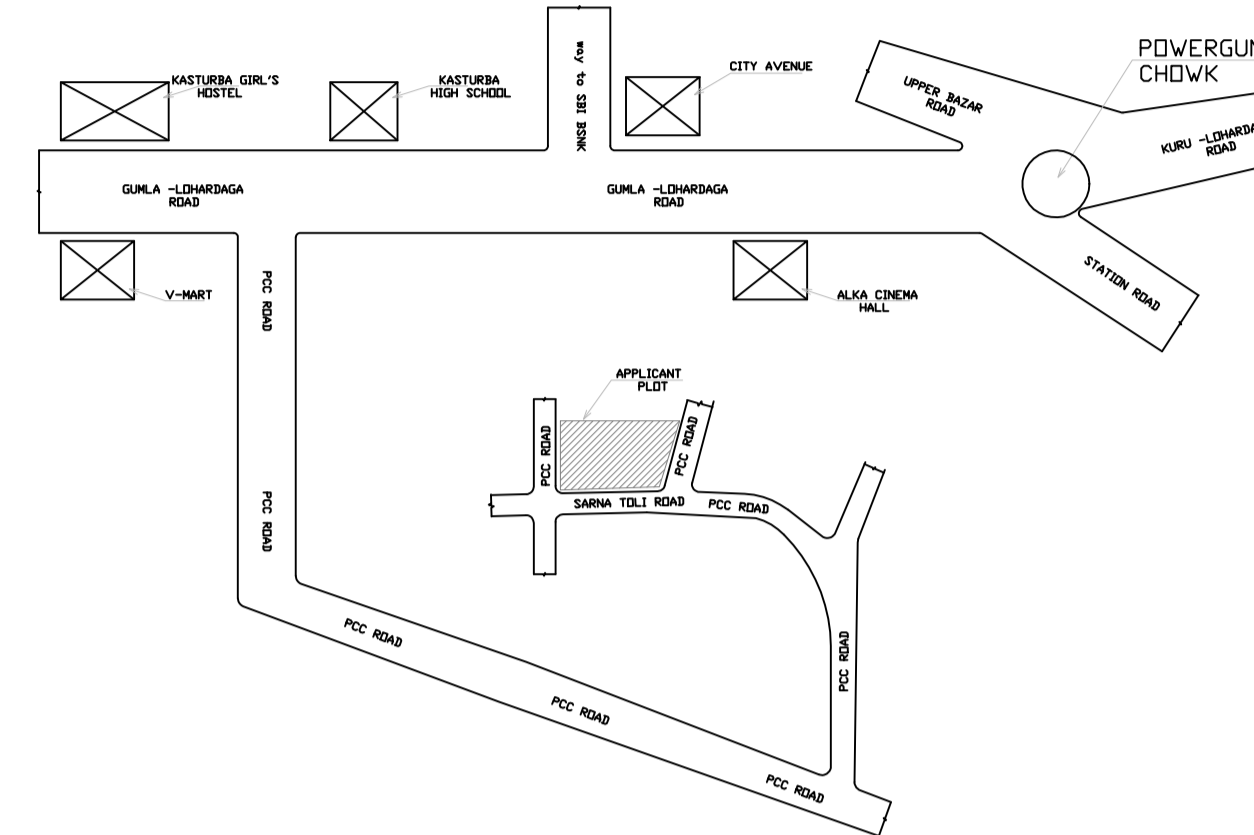

LOCATION PLAN SCALE : NTS

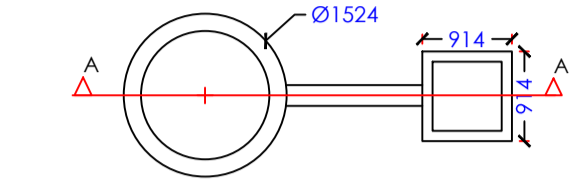

DETAIL OF GROUND WATER RECHARGING PIT WITH SLIT TANK

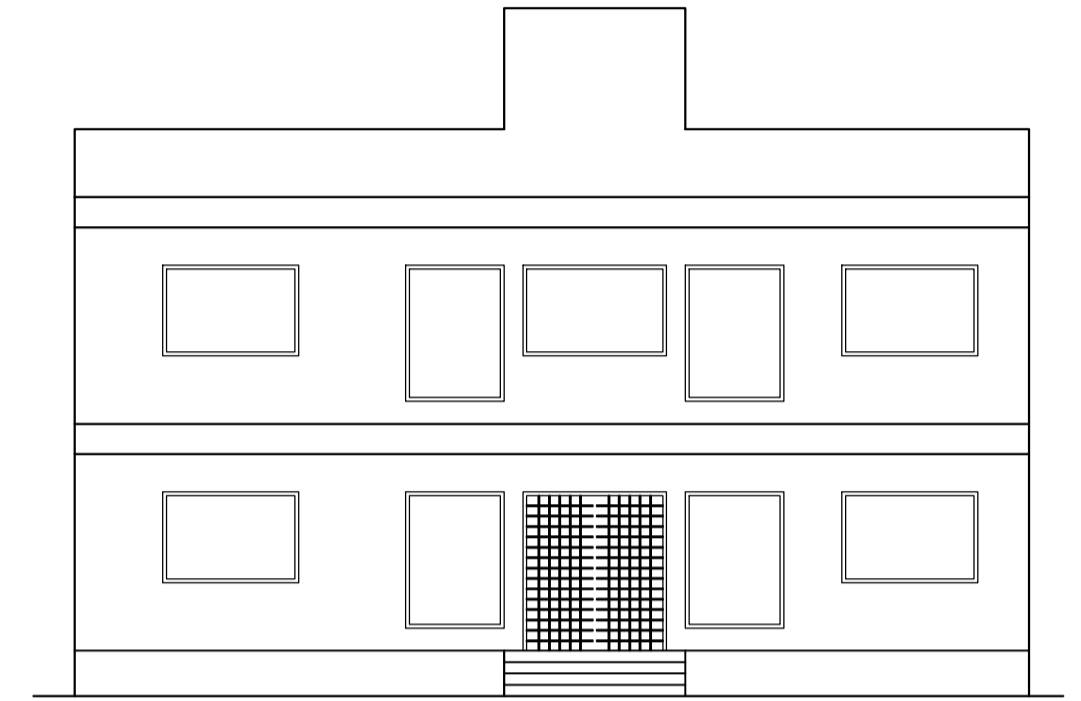
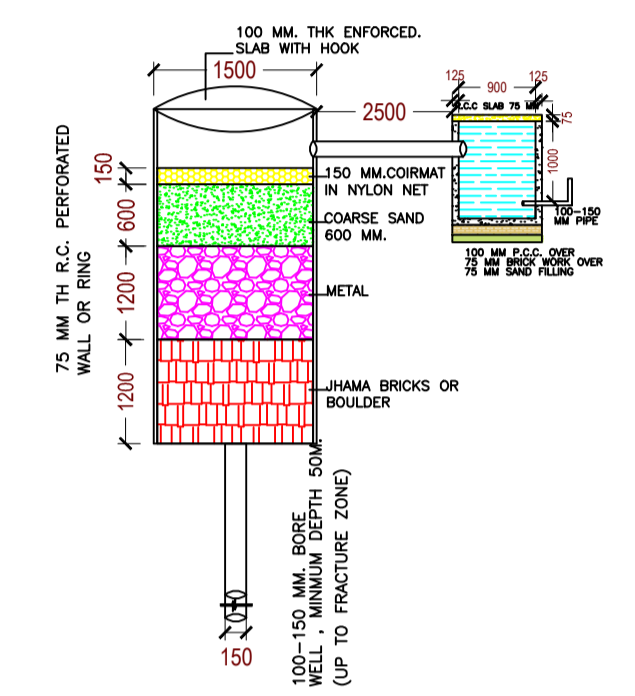

FRONT ELEVATION Scale - 1:100

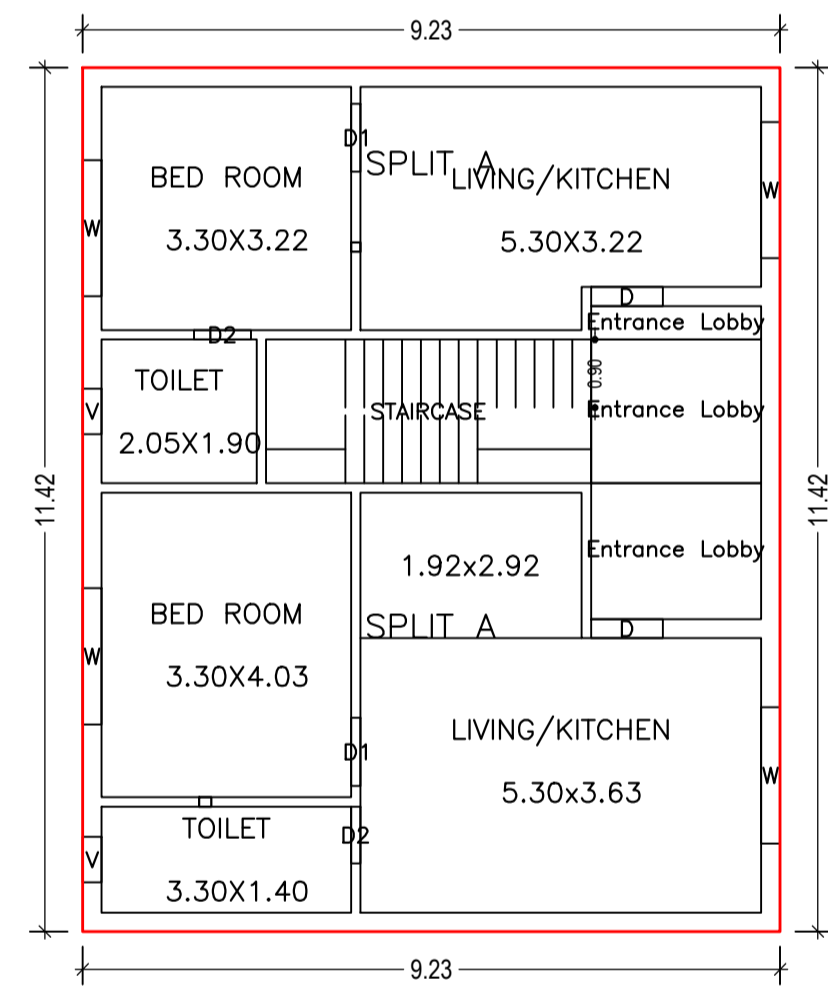

FIRST FLOOR PLAN (Proposed) (SCALE 1:100)

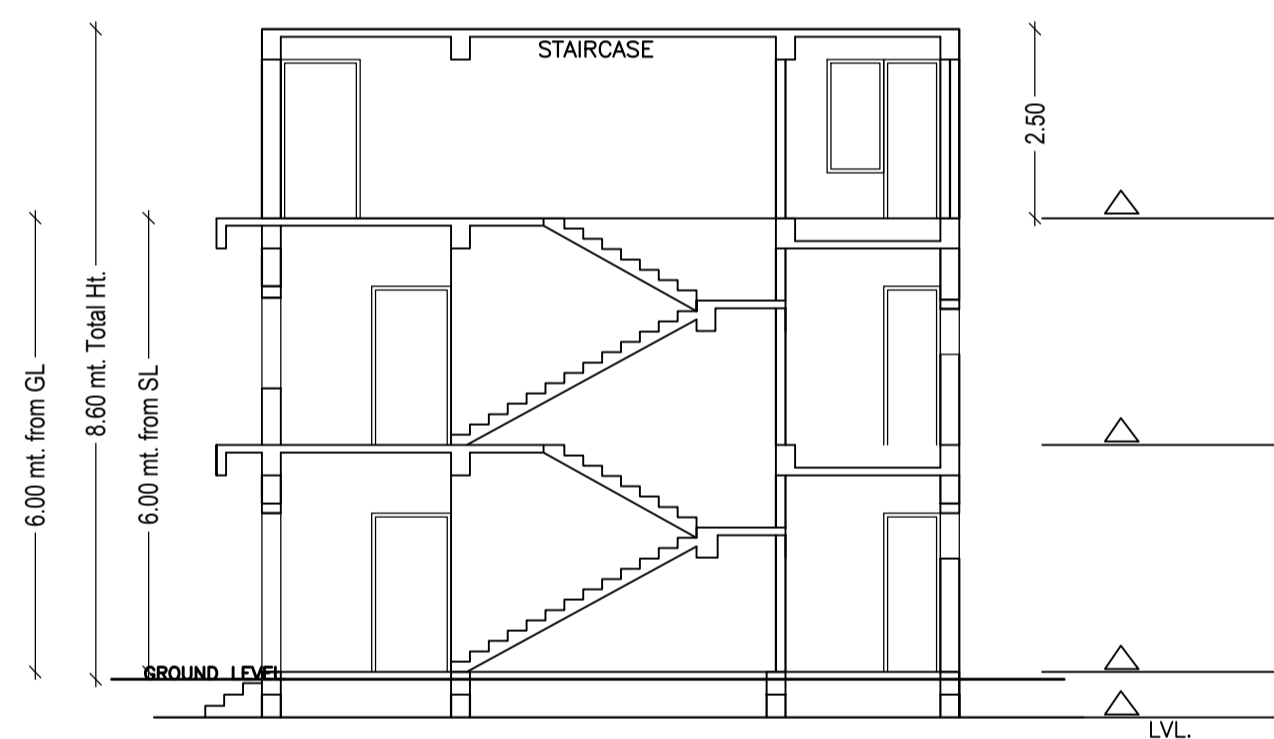

SECTION A-A Scale - 1:100

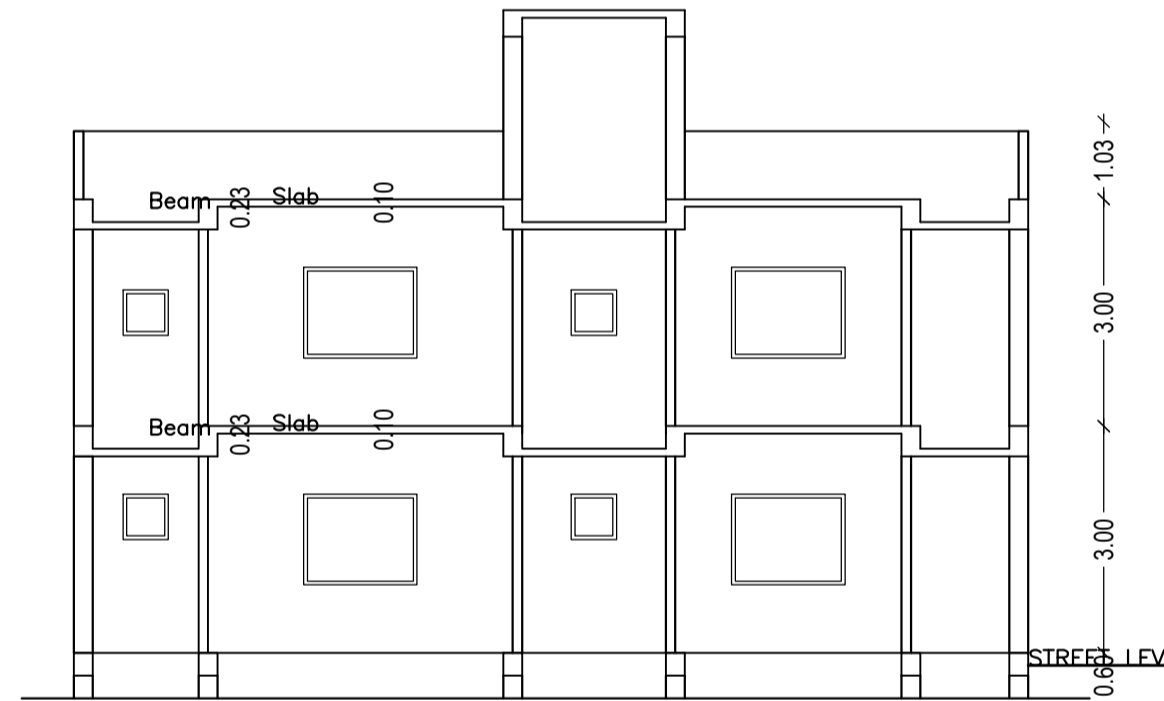

SECTION B-B Scale - 1:100

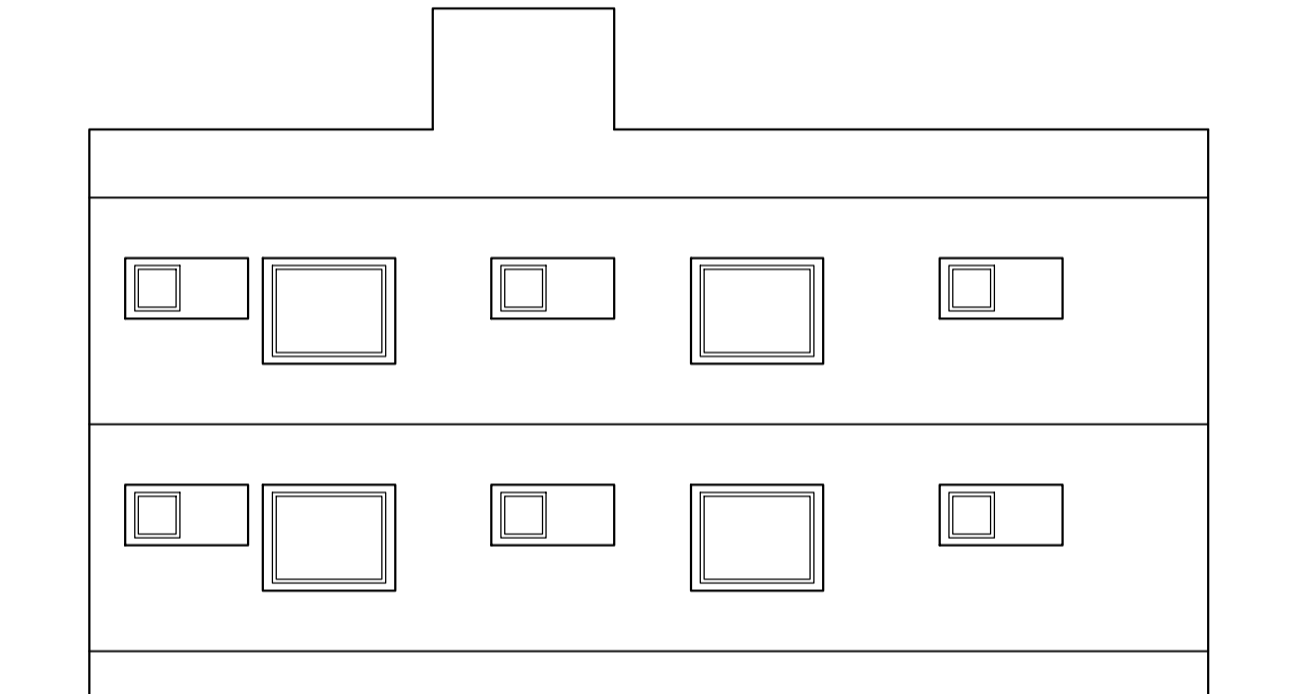

BACK SIDE ELEVATION Scale - 1:100

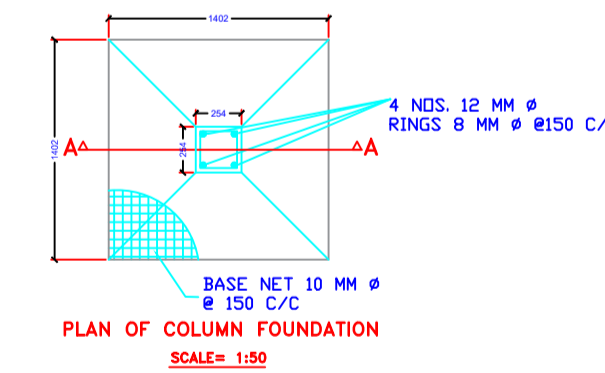

PLAN OF COLUMN FOUNDATION SCALE= 1:50

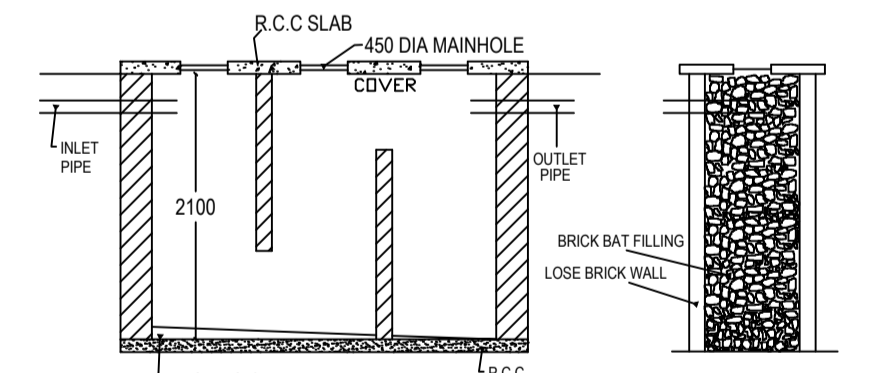

SECTION N-N.

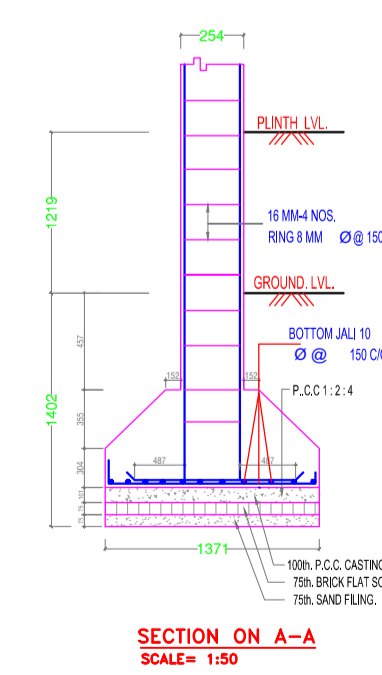

SECTION ON A-A SCALE= 1:50

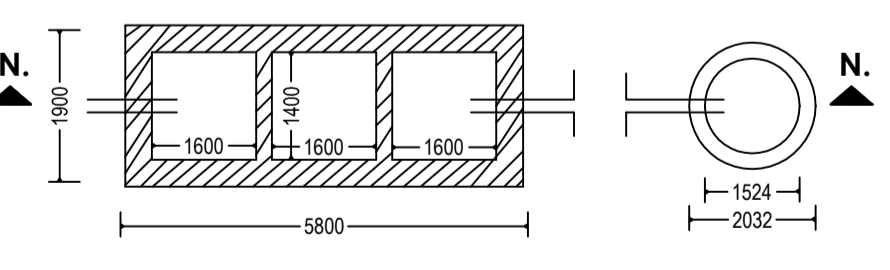

DETAIL OF SEPTIC TANK & SOAKPIT.

Building :A (AMIYA KERKETTA)

Floor Name	Total Built Up Area (Sq.mt.)	Deductions (Area in Sq.mt.)	Proposed FAR Area (Sq.mt.)	Total FAR Area (Sq.mt.)	Total Consumed Additional FAR Area (Sq.mt.)	Tnmt (No.)
Ground Floor	105.38	9.32	96.06	96.06	96.06	01
First Floor	105.38	9.32	96.06	96.06	96.06	00
Terrace Floor	0.00	0.00	0.00	0.00	0.00	00
Total :	210.76	18.64	192.12	192.12	192.12	01
Total Number of Same Buildings	1					
Total :	210.76	18.64	192.12	192.12	192.12	01

SCHEDULE OF DOOR:

BUILDING NAME	NAME	LENGTH	HEIGHT	NOS
A (AMIYA KERKETTA)	D2	0.75	2.13	04
A (AMIYA KERKETTA)	D1	0.90	2.13	04
A (AMIYA KERKETTA)	D	0.95	2.13	04

SCHEDULE OF WINDOW/VENTILATION:

BUILDING NAME	NAME	LENGTH	HEIGHT	NOS
A (AMIYA KERKETTA)	V	0.60	2.70	04
A (AMIYA KERKETTA)	W	1.80	2.70	08

UnitBUA Table for Building :A (AMIYA KERKETTA)

FLOOR	Name	UnitBUA Type	UnitBUA Area	Carpet Area	No. of Rooms	No. of Tenement
GROUND FLOOR PLAN	SPLIT A	FLAT	149.55	149.49	2	1
FIRST FLOOR PLAN	SPLIT A	FLAT	0.00	0.00	4	0
Total:	-	-	149.55	149.49	12	1

LTP NAME AND SIGNATURE	STRUCTURAL ENG'S NAME AND SIGNATURE	BUILDER NAME AND SIGNATURE	DIGITAL SIGNATURE
ASHWINI KUMAR SAHU LNP/ENG/0005/2017			

Proposal Basic Information	
Proposal File No.	LNP/BP/0029/W14/2020
Owner Name	AMIYA KERKETTA
Khata No	398, 305
Plot No	581,579
Village Name	Lohardaga
Use	Residential
SubUse	Bungalow/ Dwelling / Non Apartment

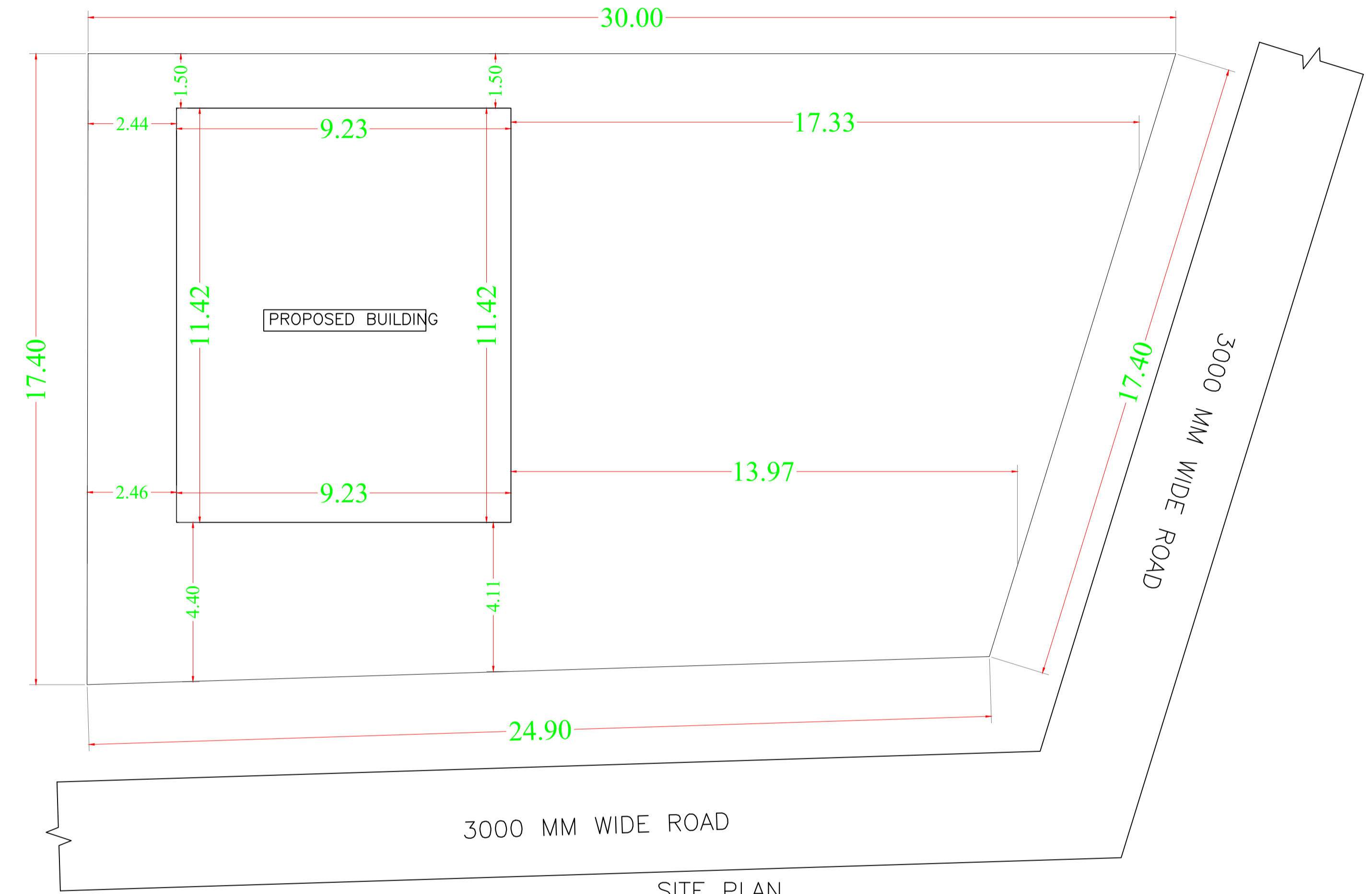

SITE PLAN
Scale - 1:100

LTP NAME AND SIGNATURE	STRUCTURAL ENG'S NAME AND SIGNATURE	BUILDER NAME AND SIGNATURE	DIGITAL SIGNATURE
ASHWINI KUMAR SAHU LNP/ENG/0005/2017			