

Project Title :SMT SUNITA BHAGAT

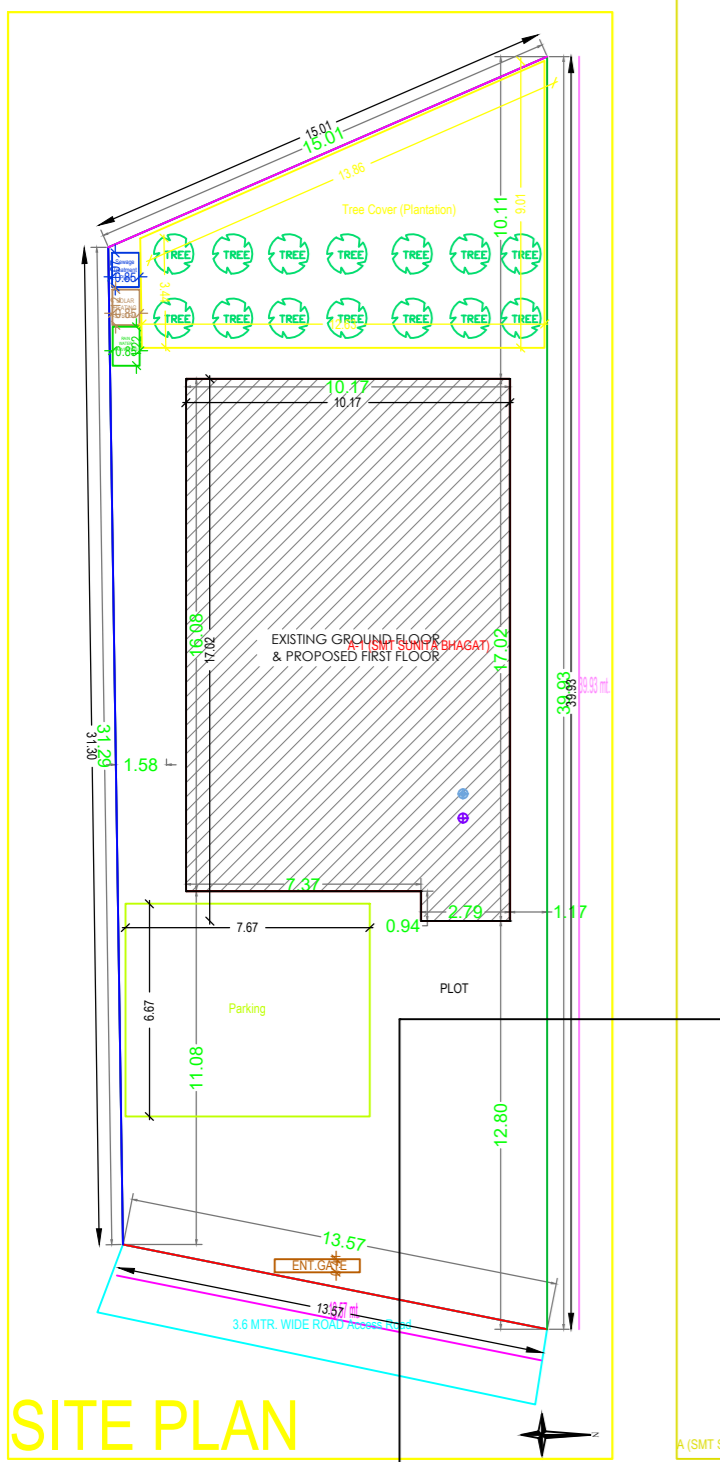
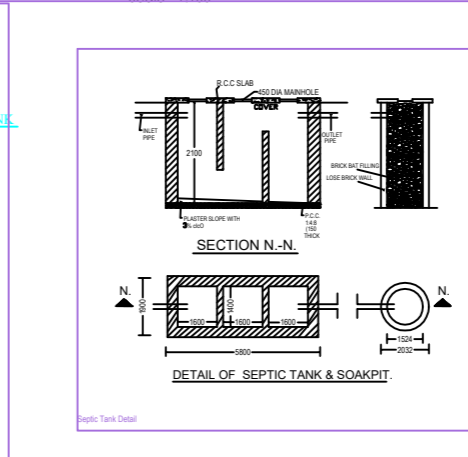
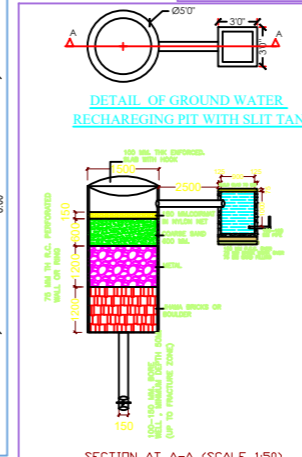
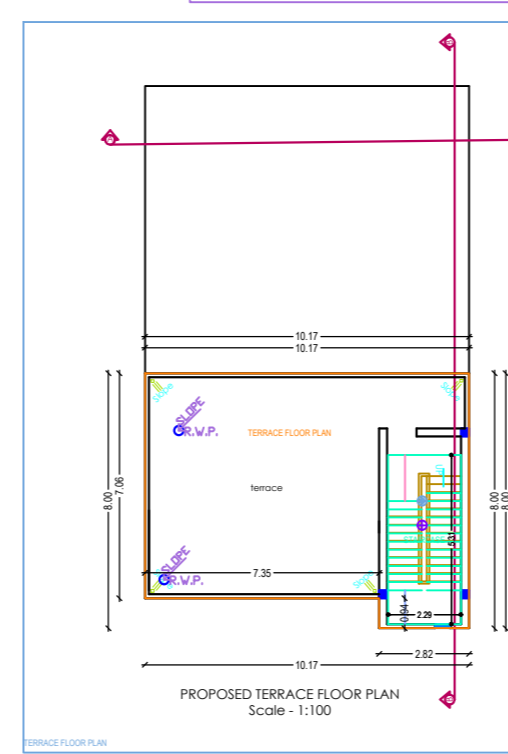
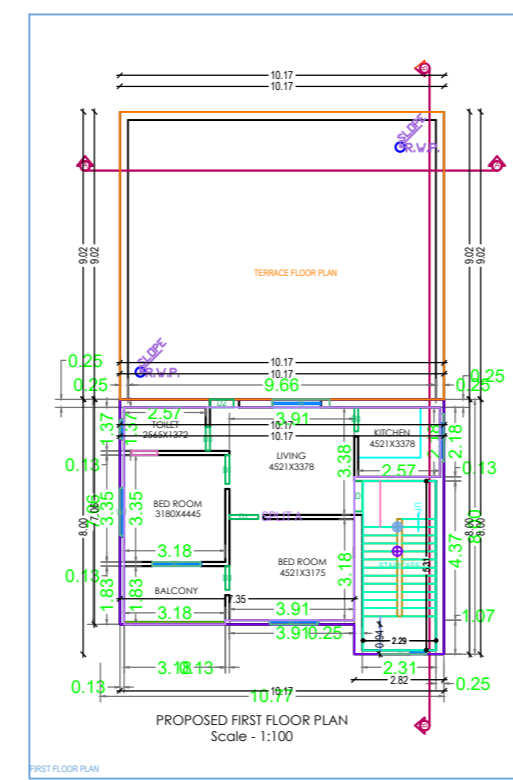
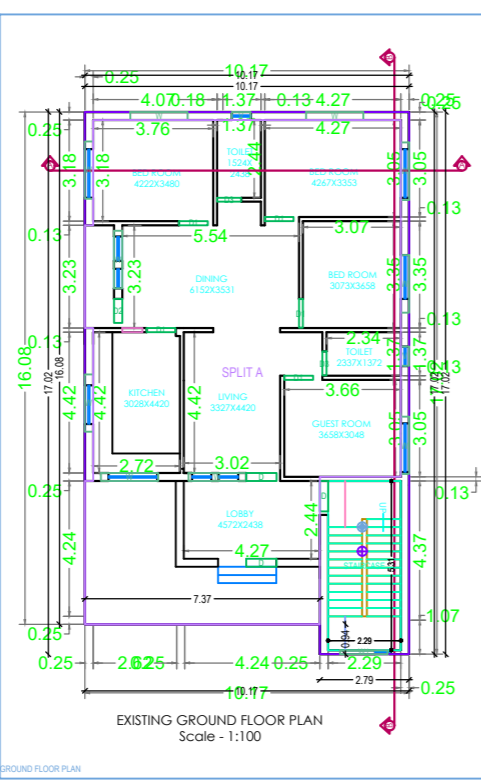
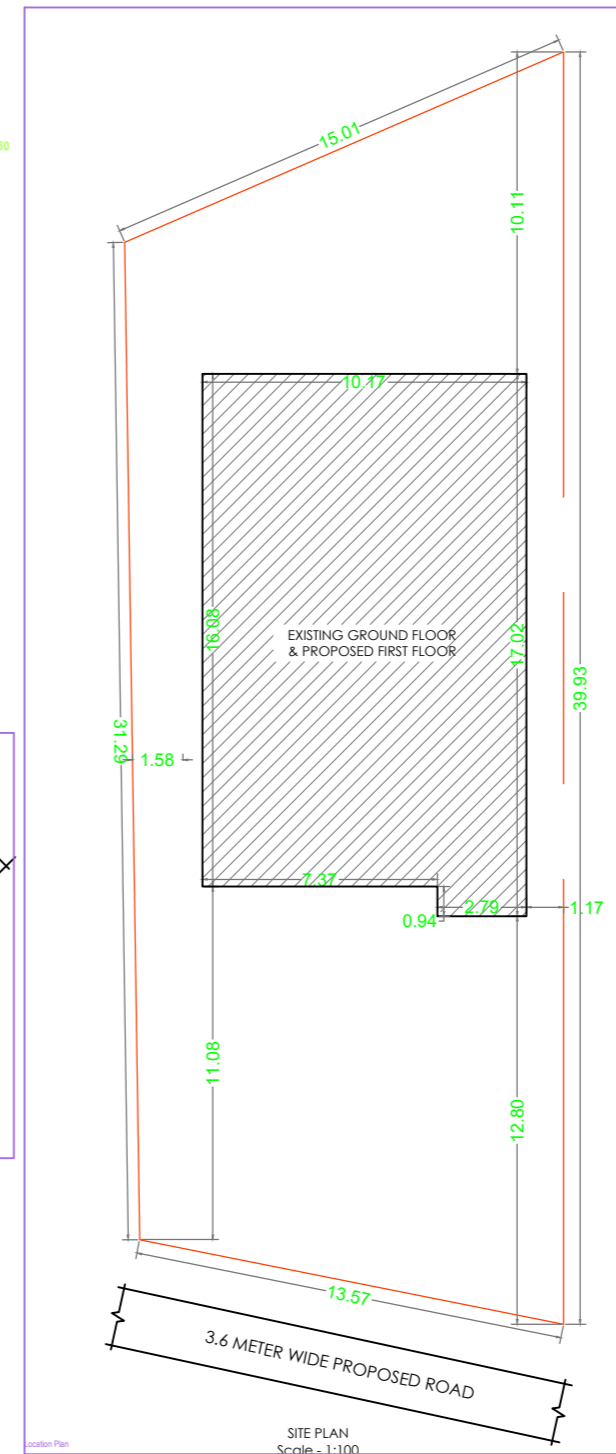
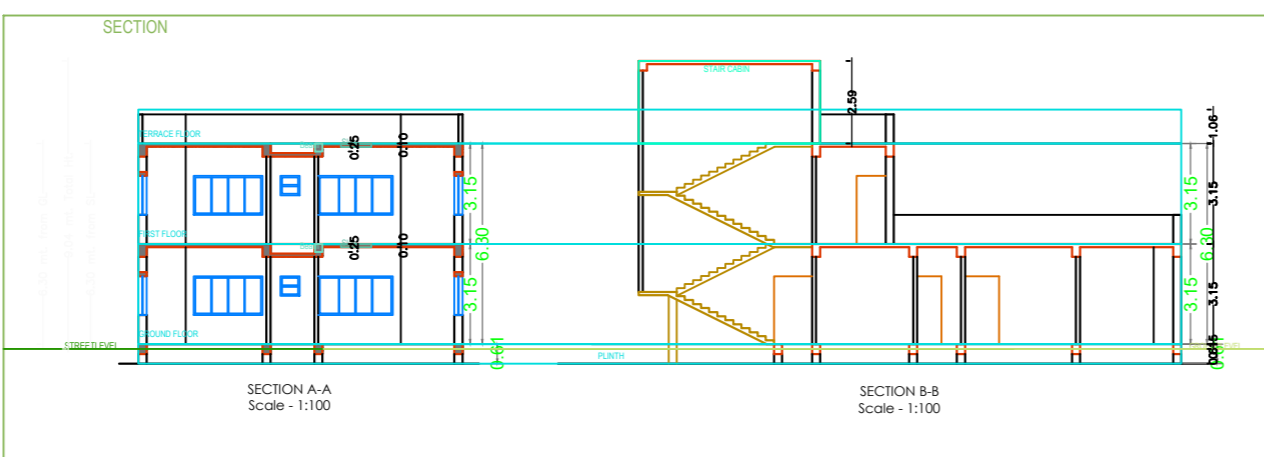
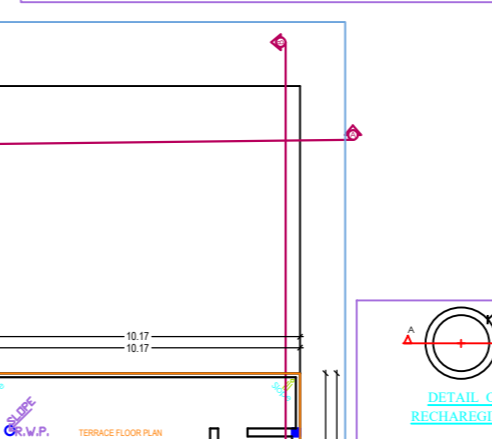
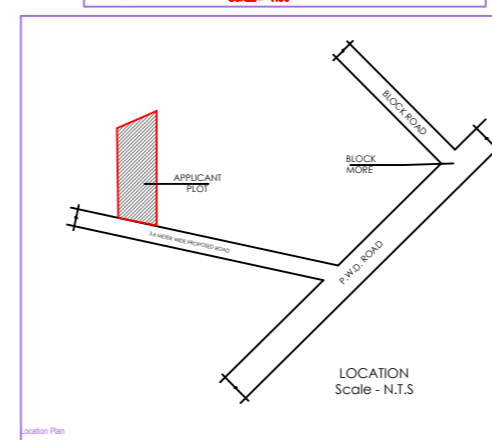
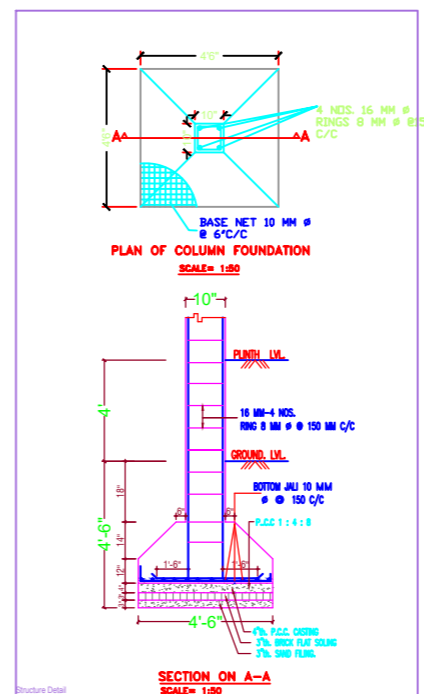
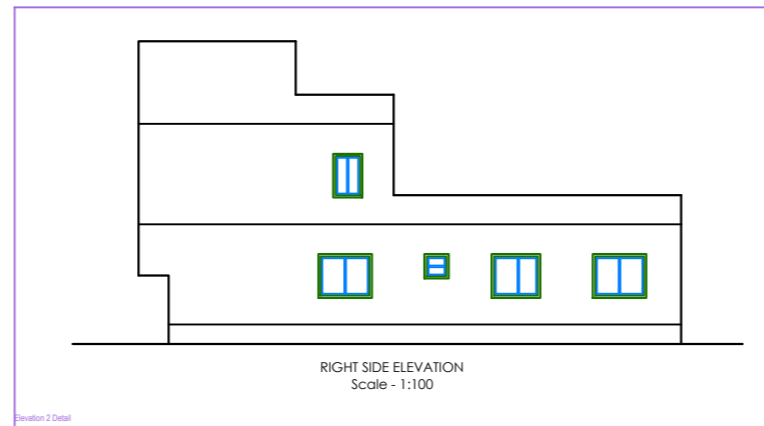
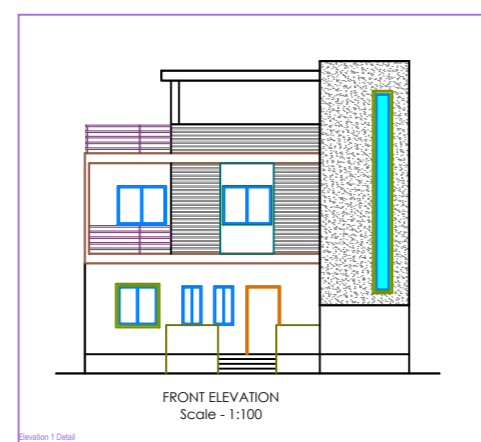

Building A (SMT SUNITA BHAGAT)

Floor Name	Total Built Up Area (Sq.m.)	Proposed FAR Area (Sq.m.)	Total FAR Area (Sq.m.)	Tent (No.)
Terrace Floor	168.00	168.00	168.00	01
First Floor	14.41	14.41	14.41	01
Ground Floor	0.00	0.00	0.00	00
Total	282.41	282.41	282.41	01
Total Number of Same Building	1	1	1	01
Total	282.41	282.41	282.41	01

SCHEDULE OF JOINERY

BUILDING NAME	NAME	LENGTH	HEIGHT	NO. OF
A (SMT SUNITA BHAGAT)	D1	2.13	0.00	01
A (SMT SUNITA BHAGAT)	D2	0.75	2.70	02
A (SMT SUNITA BHAGAT)	D1	0.99	2.13	02
A (SMT SUNITA BHAGAT)	D	0.99	2.13	04
Total				09

SCHEDULE OF JOINERY

BUILDING NAME	NAME	LENGTH	HEIGHT	NO. OF
A (SMT SUNITA BHAGAT)	V	0.60	1.00	02
A (SMT SUNITA BHAGAT)	V1	0.60	1.00	01
A (SMT SUNITA BHAGAT)	W1	1.50	2.70	06
A (SMT SUNITA BHAGAT)	W	1.80	2.70	11
Total				20

UnitBIA Table for Building A (SMT SUNITA BHAGAT)

FLOOR	Name	URBIA Type	URBIA Area	Carpet Area	No. of Rooms	No. of Tenement
GROUND FLOOR PLAN	SPLIT A	FLAT	197.55	197.36	11	1
Total			197.55	197.36	11	1

AREA STATEMENT (OPHWADA NAGAR PARISHAD)	VERSION NO. 1.0.26
PROJECT DETAIL:	VERSION DATE: 16/10/2020
Plot No.:	Plot Use: Residential
Region: URBAN/URBAN LOCAL BODIES	Plot Section: Bangalore Choultry New Apartment
District: OPHWADA	Land Use Zone: NA
Subdivision: Upr. General Proposal	Planning Road Width: -
Project: Prop. Building Permission	Plot No.:
Nature of Development: New	Reference Survey No/Survey No.:
Location: 102 Area	Town No.:
S/S Location: NA	Building No.:
Proposed Area Name:	Area No.:
Road No.:	Sub-:
Road/Street: -	East:
	West:

AREA CHECK

ITEMS	UNIT	AMOUNT
Net Plot Area (Gross Plot Area)	(A-Deductions)	482.39
Deduction from Gross Plot Area	(A-Deductions)	482.39
Net Plot Area for Balance PFA Area (Net Gross Plot Area)		16.83
Plot Area		16.83
Balance Plot Area (Net Plot Area)		16.83
Balance Plot Area (Net Plot Area)	(A-Deductions)	16.83
Plot Area for Coverage (Net Plot Area)	(A-Deductions)	403.52
Plot Area for FSI (Net Plot Area + Quality/Amenity Area)	(A-Deductions)	482.39
Plot Area for FSI (Net Plot Area + Quality/Amenity Area)	(A-Deductions)	482.39
Accessory/Use Area		0.91
COVERAGE CHECK		
Proposed Coverage Area (34.42 %)		166.05
Plot Coverage Area (34.42 %)		166.05
FAR CHECK		
Proposed Area of FAR		240.49
Plot Area of FAR		240.49
RESULT OF AREA CHECK		
Final Proposed Building Area		240.49
Actual Built Up Area		240.49
ADDITIONAL AUTHORITY		LOCAL BODY

COLOR INDEX

BOUNDARY TYPE	COLOR
PLLOT BOUNDARY	Black
ADJUTING ROAD	Red
PROPOSED HIGH COVERAGE AREA	Green
EXISTING (To be retained)	Blue
EXISTING (To be demolished)	Yellow

PARKING CALCULATION

Parking Type	Prop. No.	Prop. Area
Other Parking	1	21.16
Total Area		51.16

MARGIN DETAIL:

Building Width	Street Width	Front Margin	Rear Margin	Side Margin	Side2 Margin
4.15	3.30	1.25	4.75	2.13	1.17

FAR & Tenement Details (Table 4c-1)

Building	No. of Same Bldg.	Total Built Up Area (Sq.m.)	Proposed FAR Area (Sq.m.)	Total FAR Area (Sq.m.)	Tent (No.)
A (SMT SUNITA BHAGAT)	1	240.49	240.49	240.49	01
Total	1	240.49	240.49	240.49	01