

PROPOSED WORK		REVISIONS	
NO.	DESCRIPTION	NO.	DESCRIPTION
1	ISSUED FOR PERMIT	1	REVISION
2	ISSUED FOR PERMIT	2	REVISION
3	ISSUED FOR PERMIT	3	REVISION
4	ISSUED FOR PERMIT	4	REVISION
5	ISSUED FOR PERMIT	5	REVISION
6	ISSUED FOR PERMIT	6	REVISION
7	ISSUED FOR PERMIT	7	REVISION
8	ISSUED FOR PERMIT	8	REVISION
9	ISSUED FOR PERMIT	9	REVISION
10	ISSUED FOR PERMIT	10	REVISION

COLOR INDEX	
Red	WALL
Blue	DOOR
Green	WINDOW
Yellow	CEILING
Grey	FLOOR

BILL OF MATERIALS				
Item	Description	Quantity	Unit	Remarks
1	Concrete	100	m ³	
2	Brick	10000	nos	
3	Steel	100	kg	
4	Plaster	100	m ²	
5	Paint	100	kg	
6	Tile	100	m ²	
7	Window	100	m ²	
8	Door	100	m ²	
9	Roof	100	m ²	
10	Foundation	100	m ²	

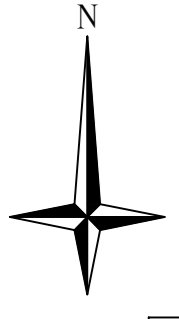
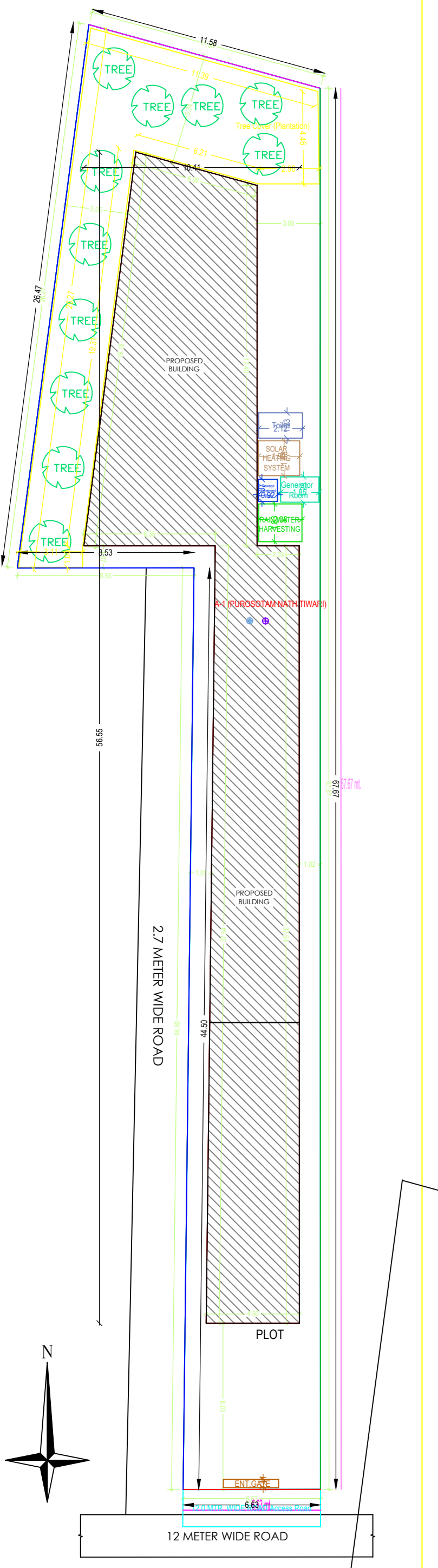
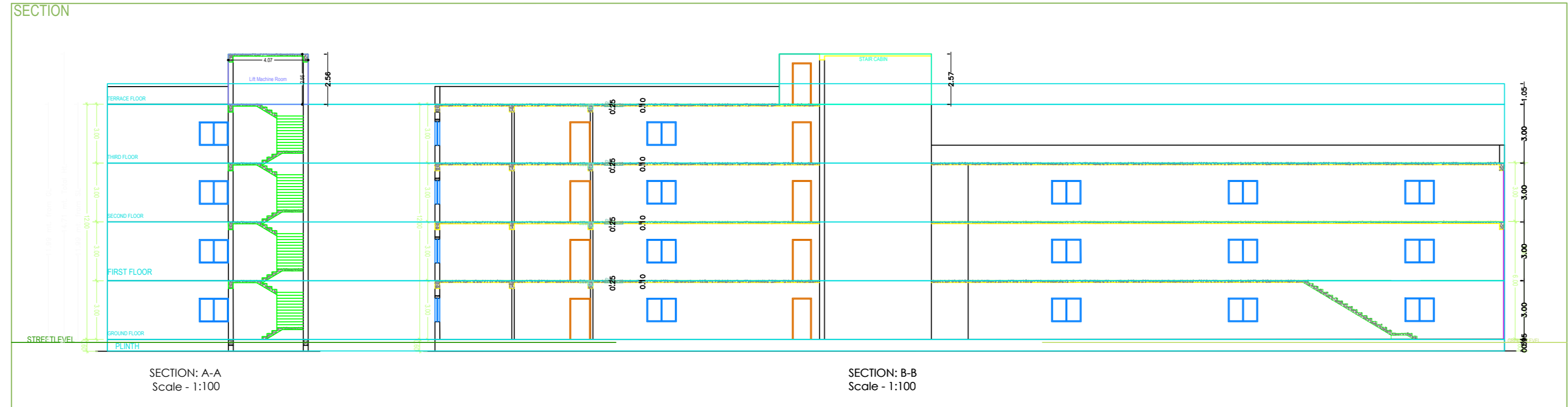
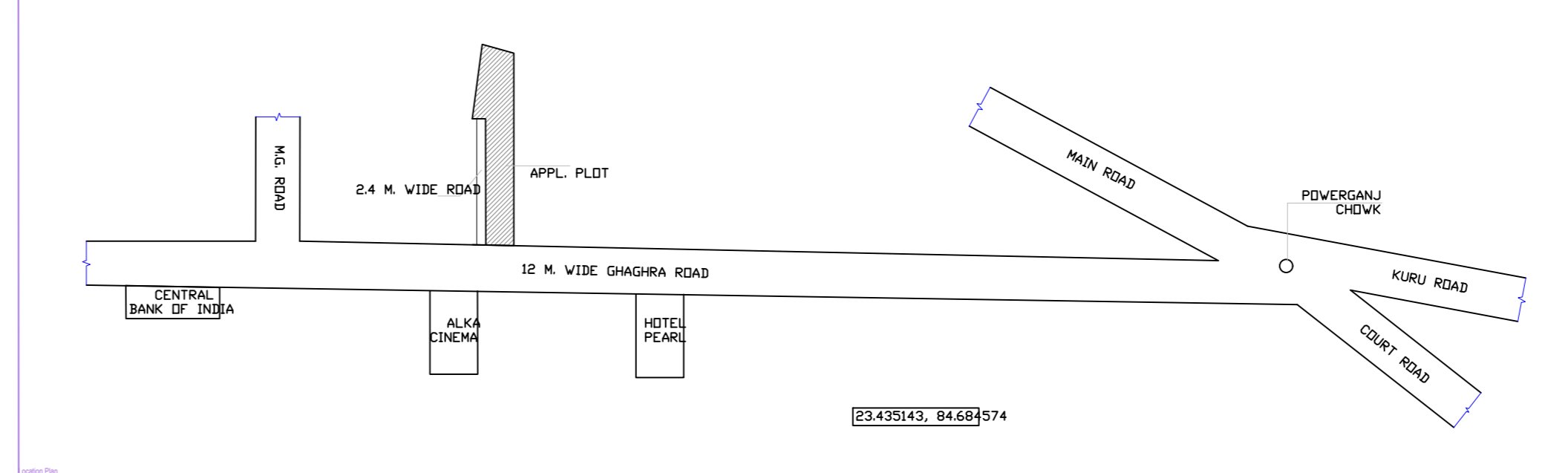

SITE PLAN

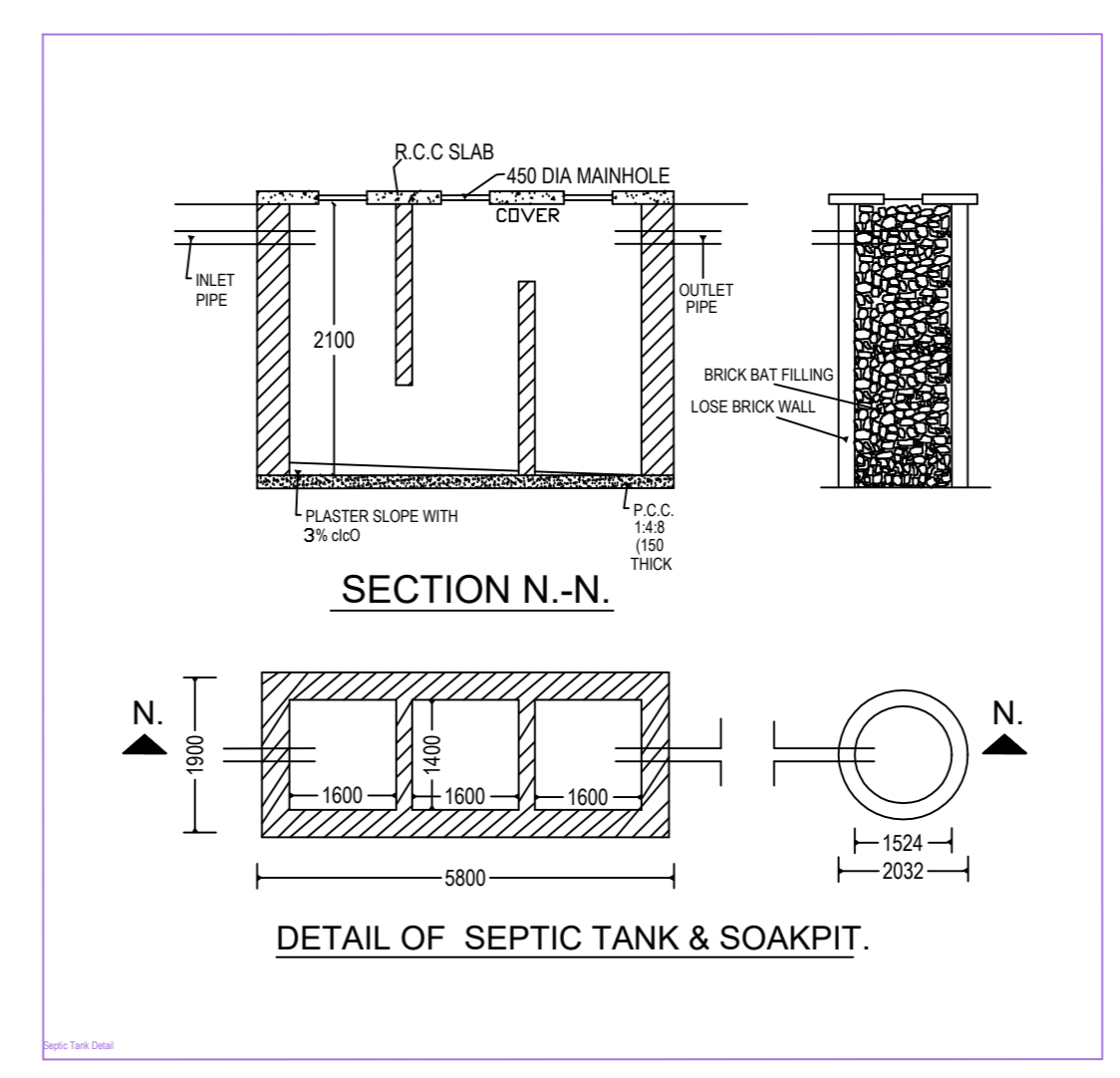
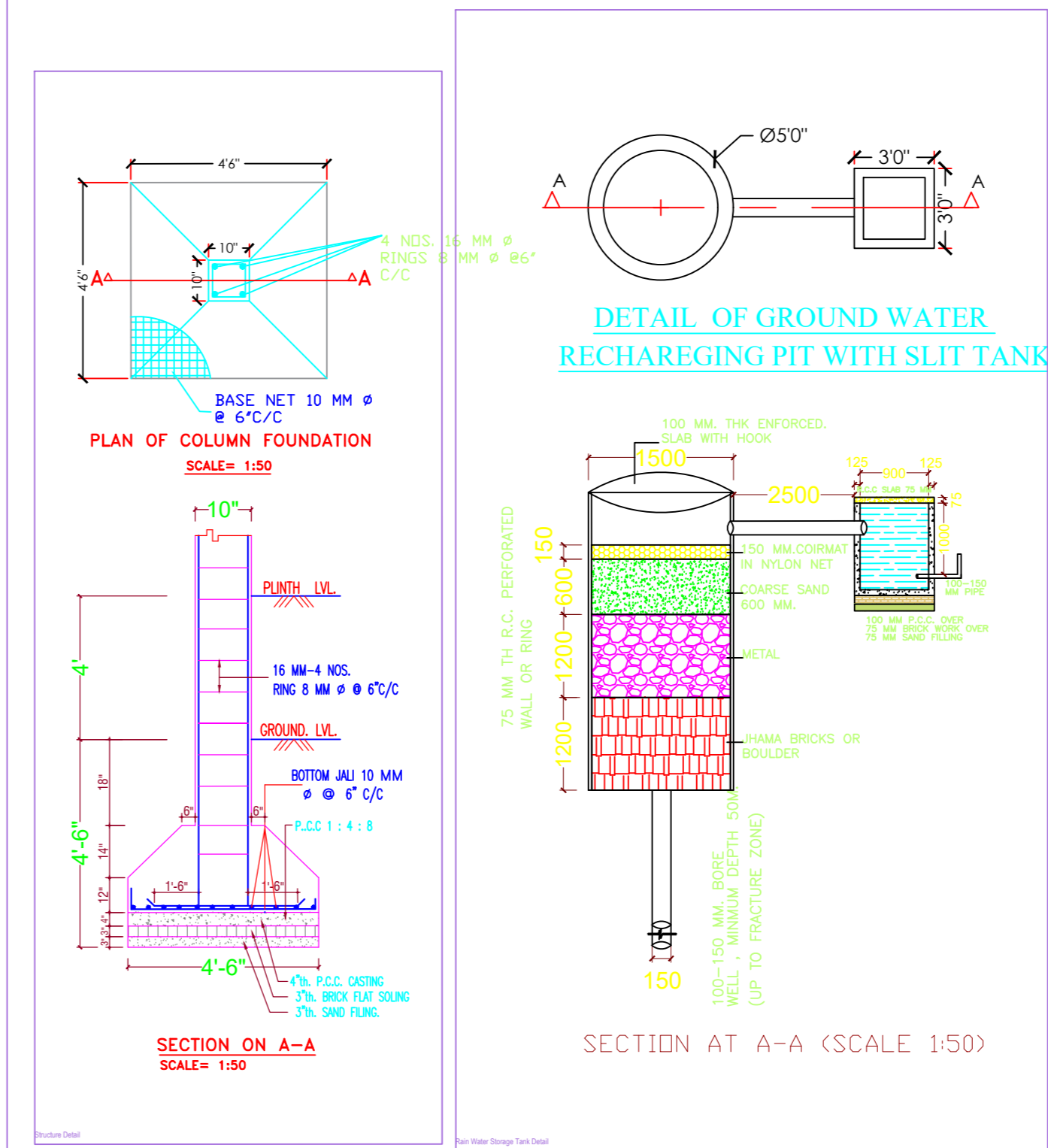
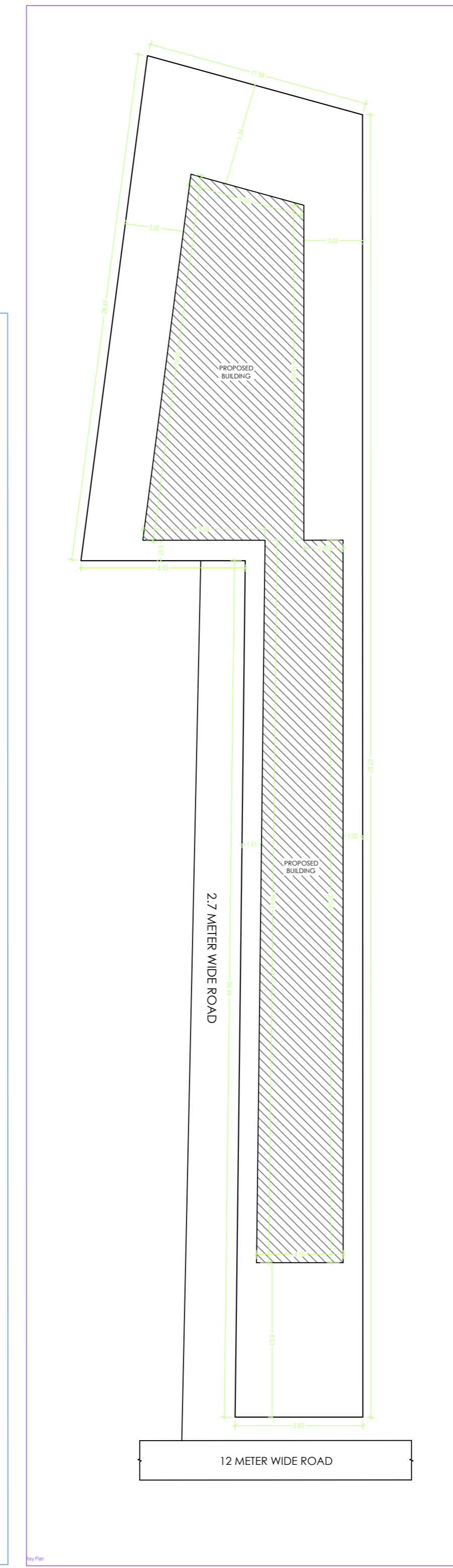
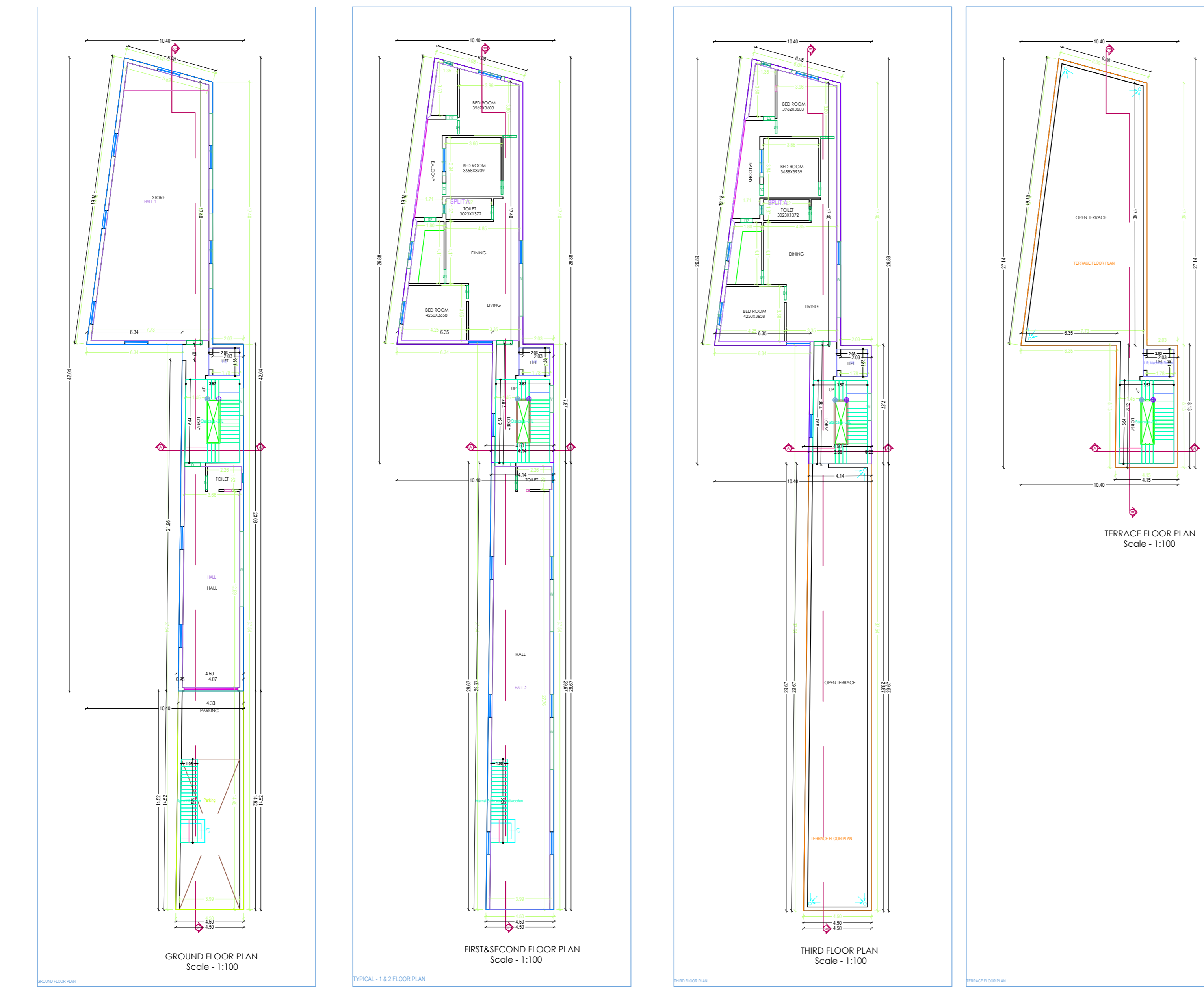

Building: PUROSOTAM NATH TIWARI

Sl. No.	Particulars	Quantity	Unit	Rate	Amount
1	Concrete	100	m ³	1000	100000
2	Brick	10000	nos	100	1000000
3	Steel	100	kg	10000	1000000
4	Plaster	100	m ²	1000	100000
5	Paint	100	kg	10000	1000000
6	Tile	100	m ²	10000	1000000
7	Window	100	m ²	10000	1000000
8	Door	100	m ²	10000	1000000
9	Roof	100	m ²	10000	1000000
10	Foundation	100	m ²	10000	1000000

SCHEDULE OF JOBBY					
Sl. No.	Description	Quantity	Unit	Rate	Amount
1	Excavation	100	m ³	1000	100000
2	Foundation	100	m ²	1000	100000
3	Structure	100	m ²	1000	100000
4	Plaster	100	m ²	1000	100000
5	Paint	100	kg	10000	1000000
6	Tile	100	m ²	10000	1000000
7	Window	100	m ²	10000	1000000
8	Door	100	m ²	10000	1000000
9	Roof	100	m ²	10000	1000000
10	Foundation	100	m ²	10000	1000000

SCHEDULE OF JOBBY					
Sl. No.	Description	Quantity	Unit	Rate	Amount
1	Excavation	100	m ³	1000	100000
2	Foundation	100	m ²	1000	100000
3	Structure	100	m ²	1000	100000
4	Plaster	100	m ²	1000	100000
5	Paint	100	kg	10000	1000000
6	Tile	100	m ²	10000	1000000
7	Window	100	m ²	10000	1000000
8	Door	100	m ²	10000	1000000
9	Roof	100	m ²	10000	1000000
10	Foundation	100	m ²	10000	1000000