

# Project Title :RAJESH KUMAR AND SWETA KESHRI

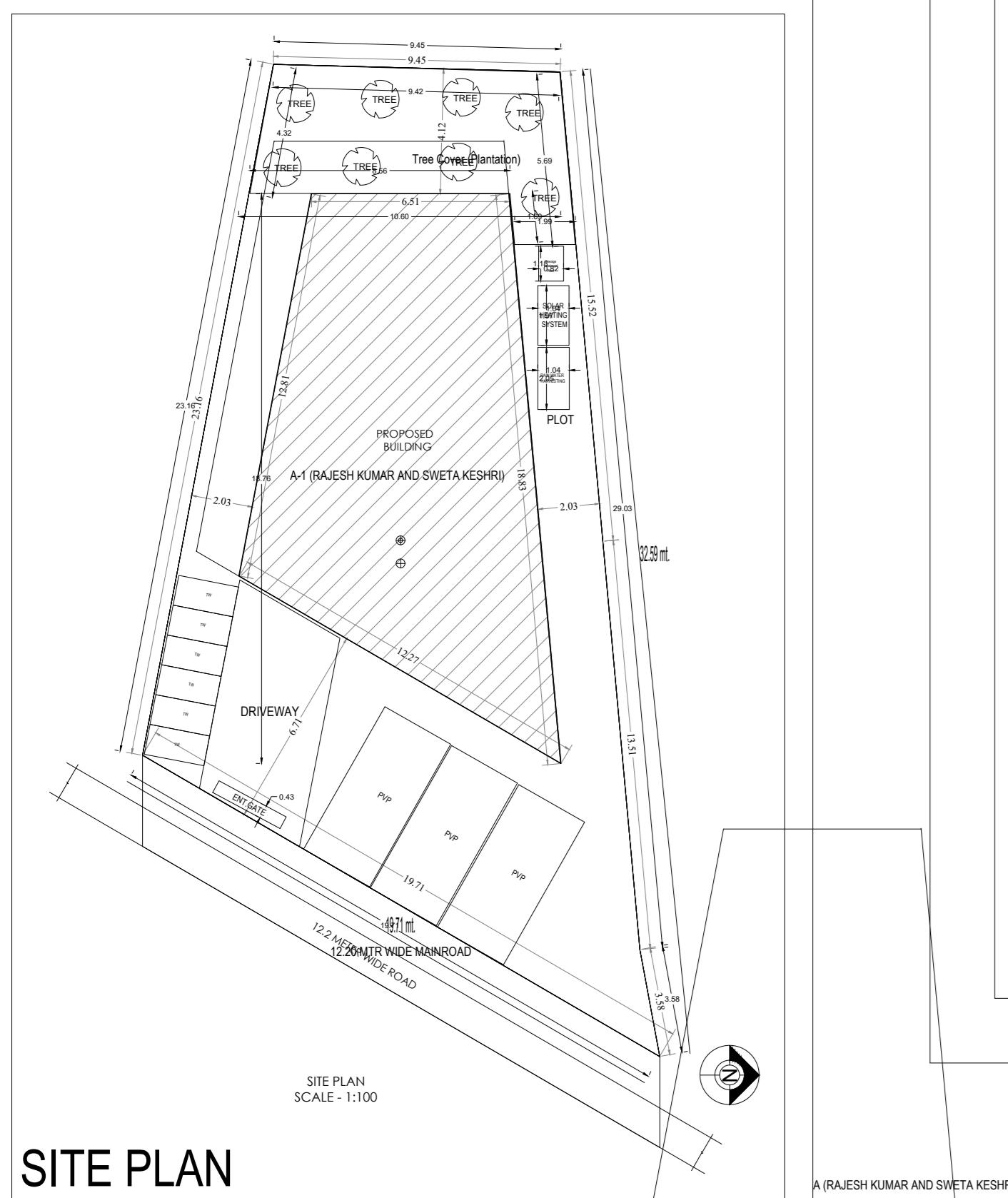
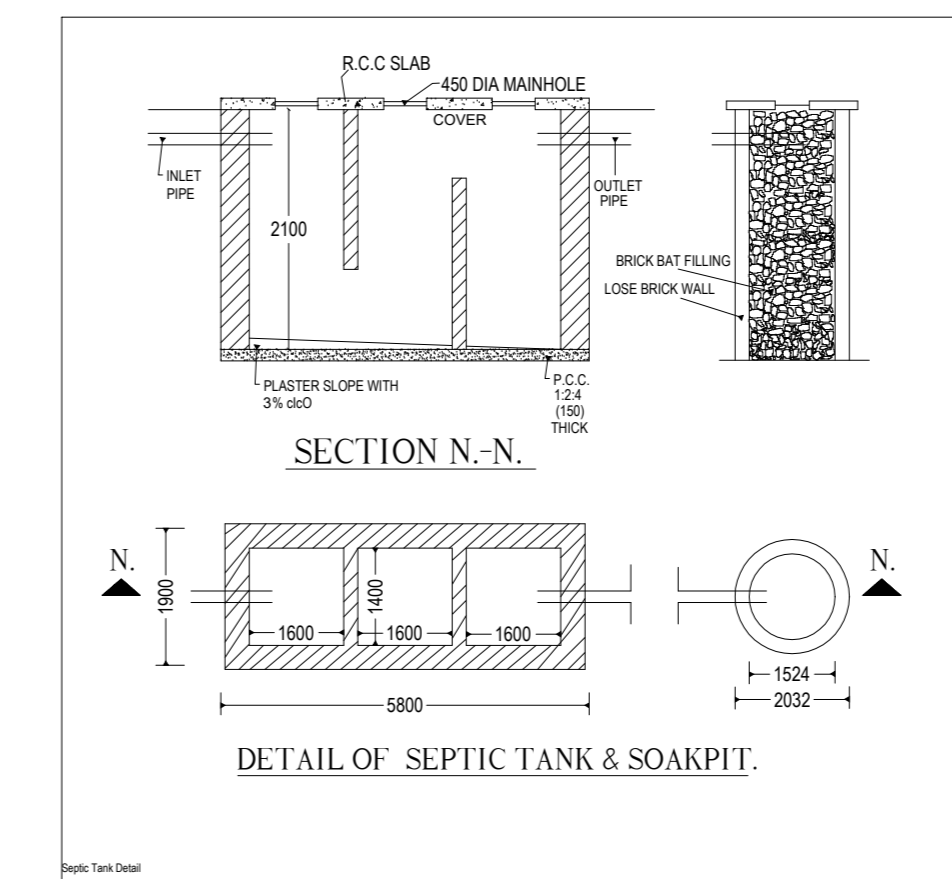
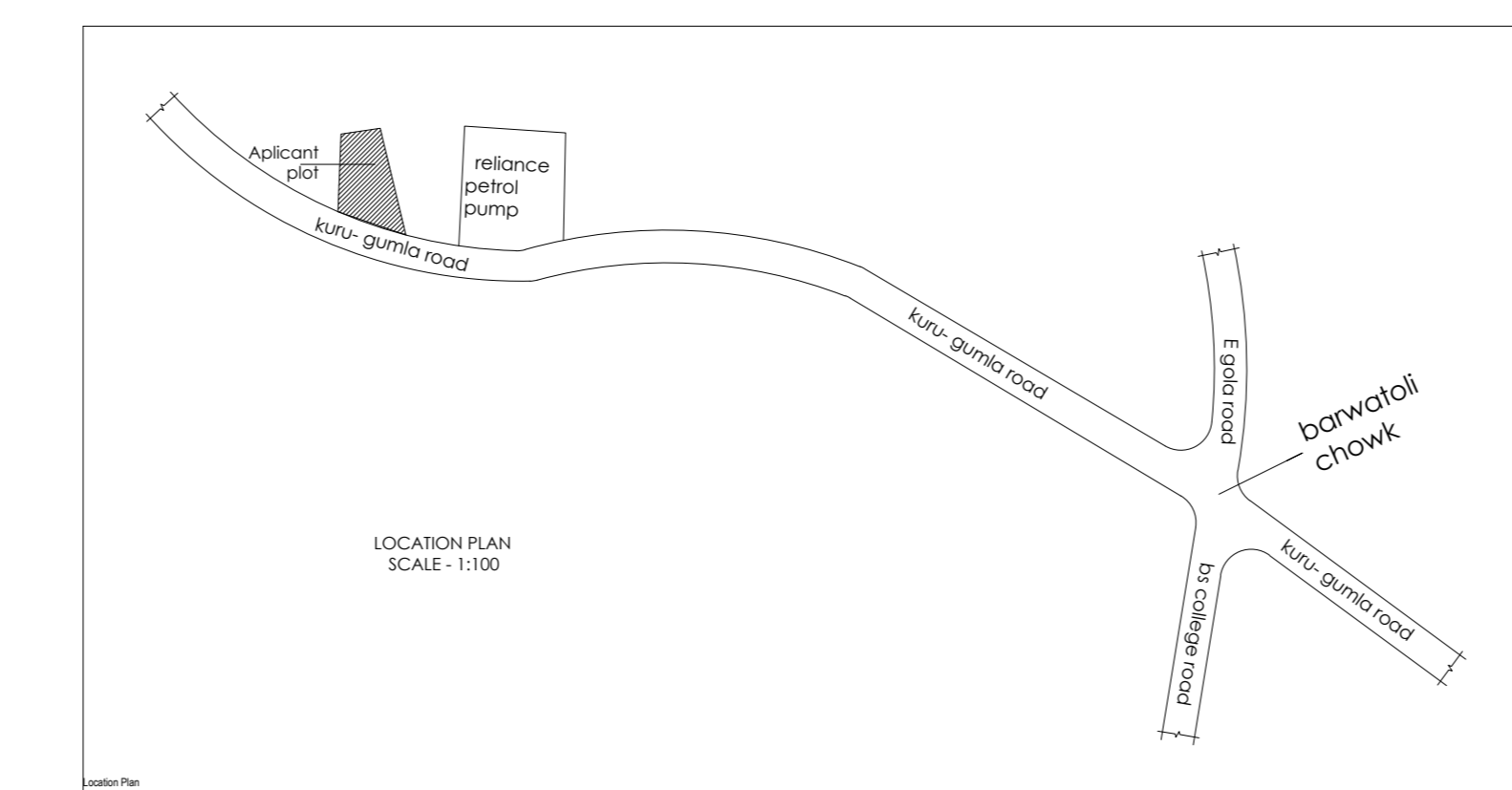
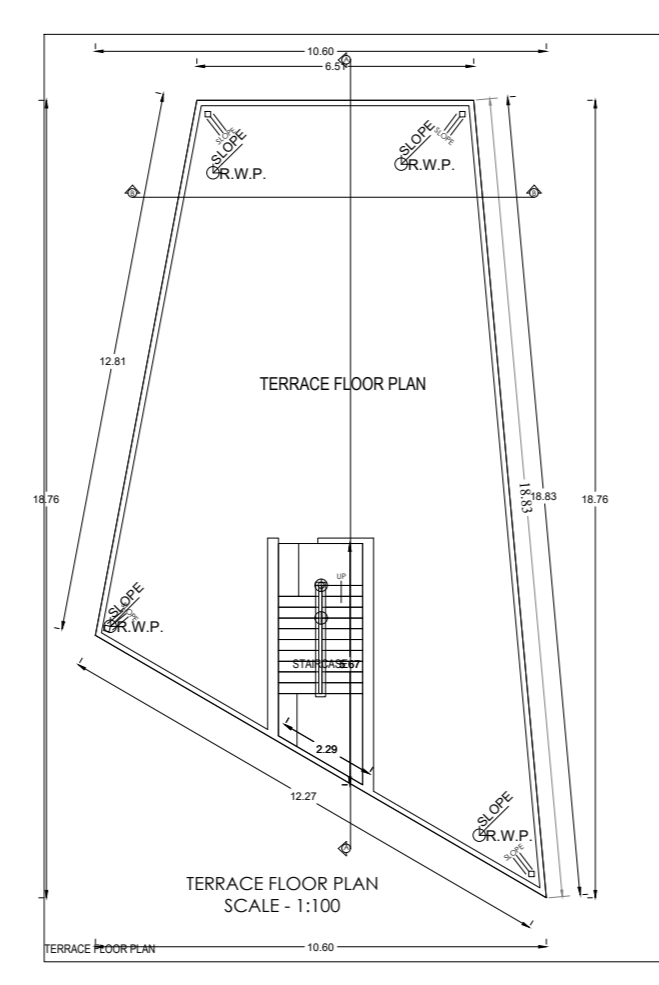
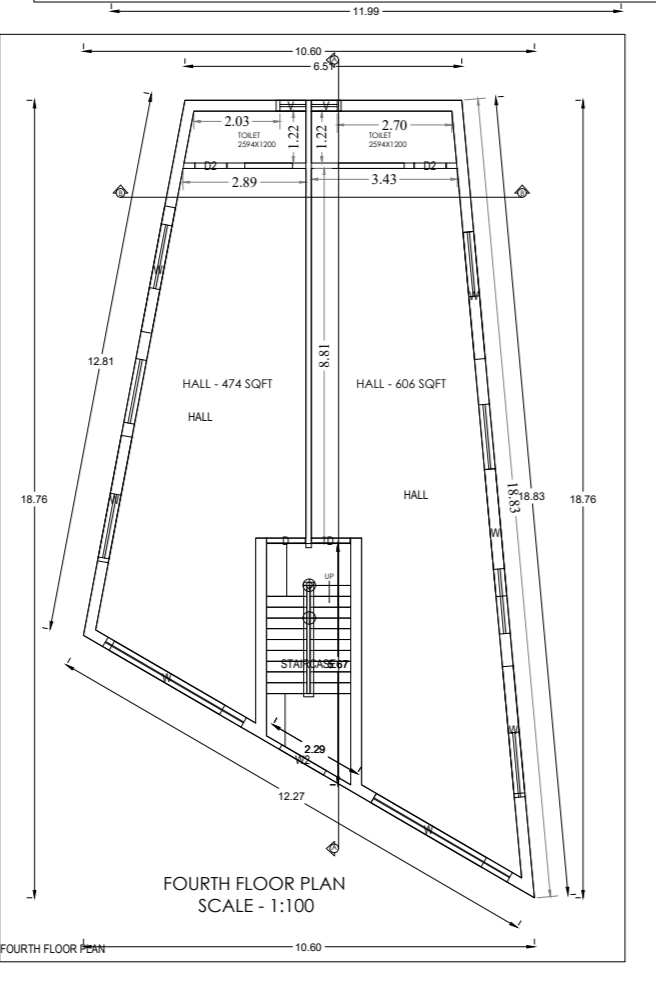
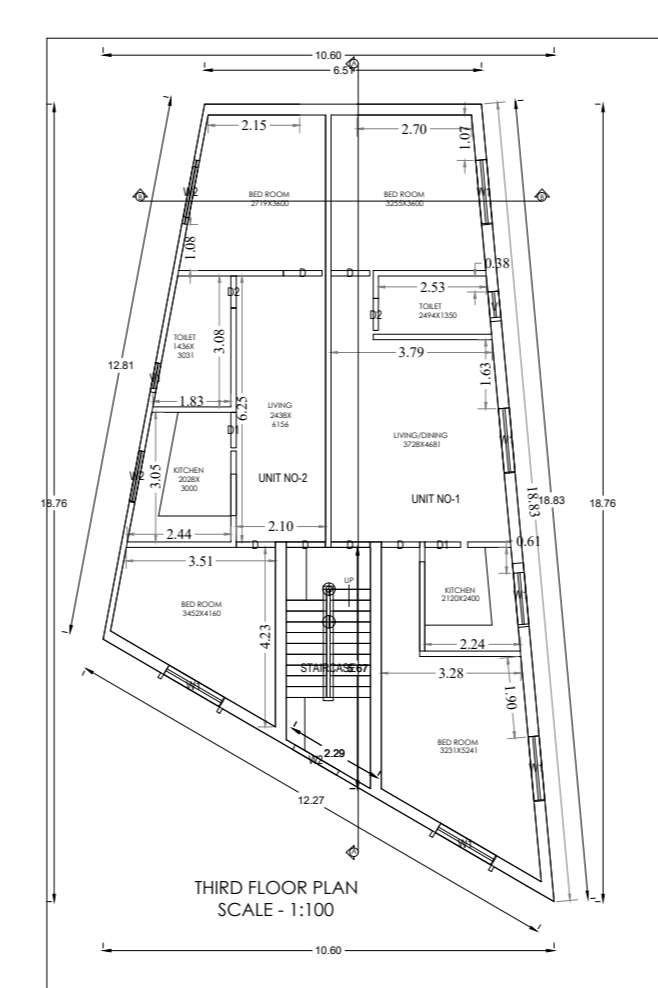
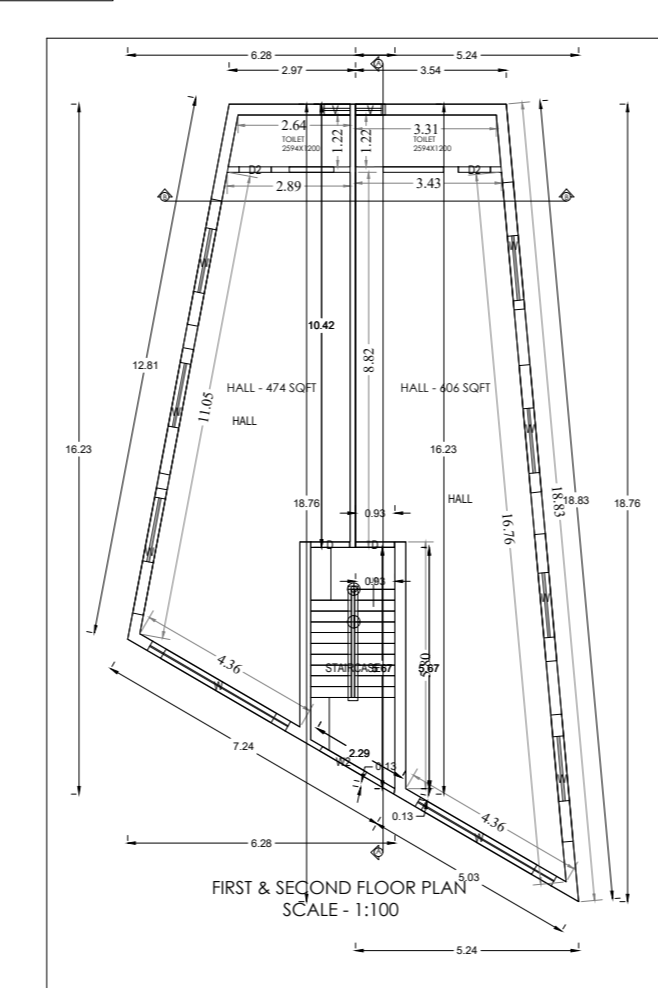
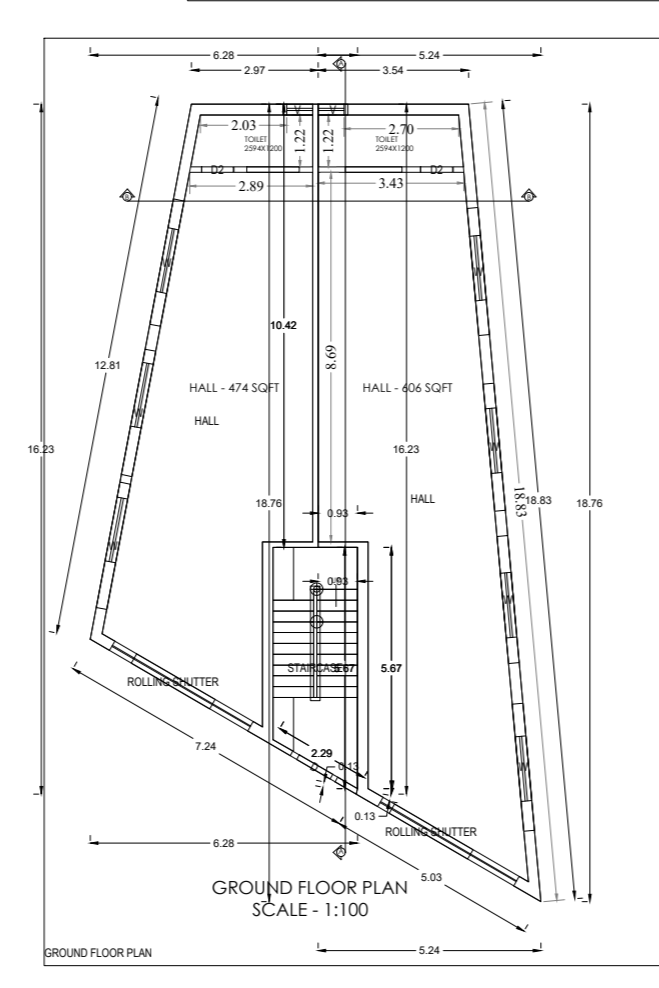
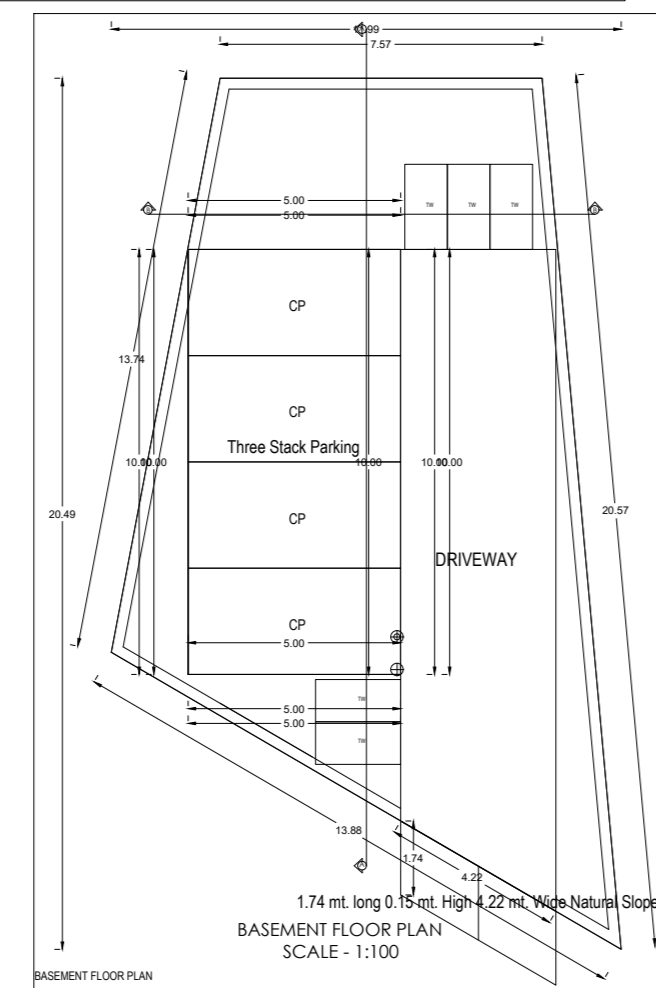
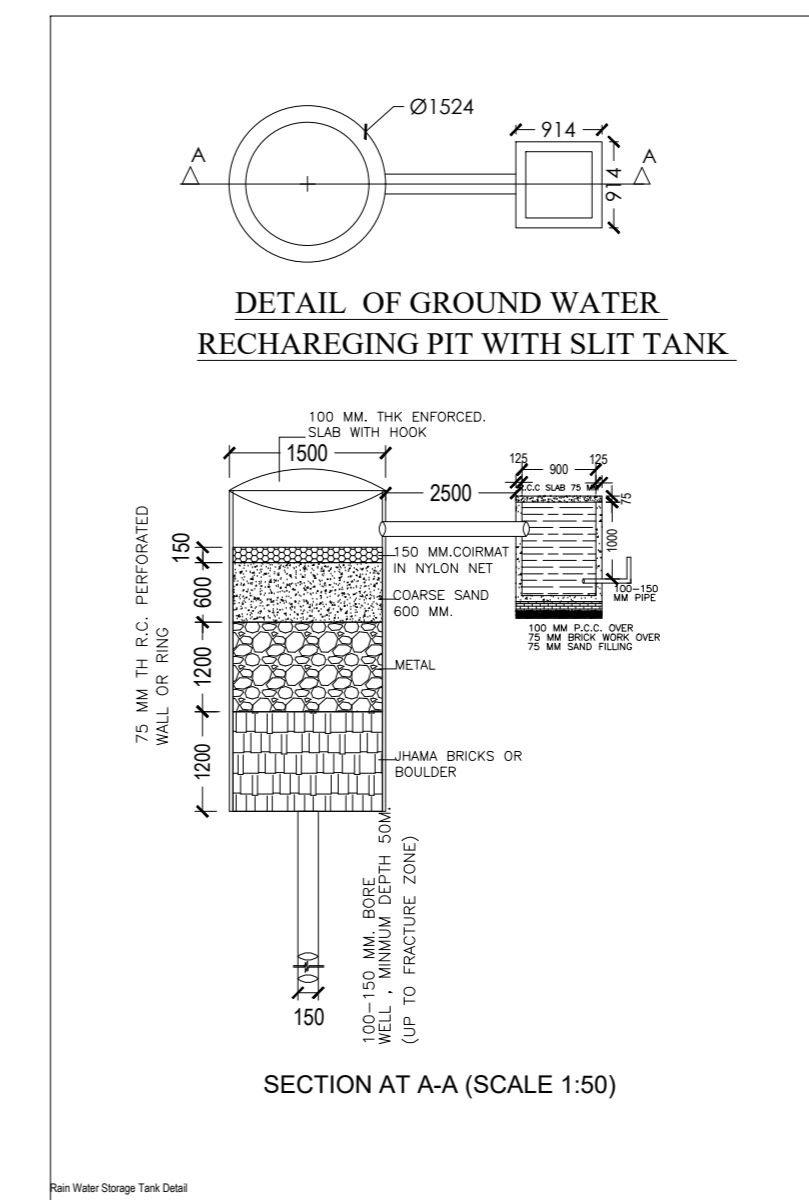
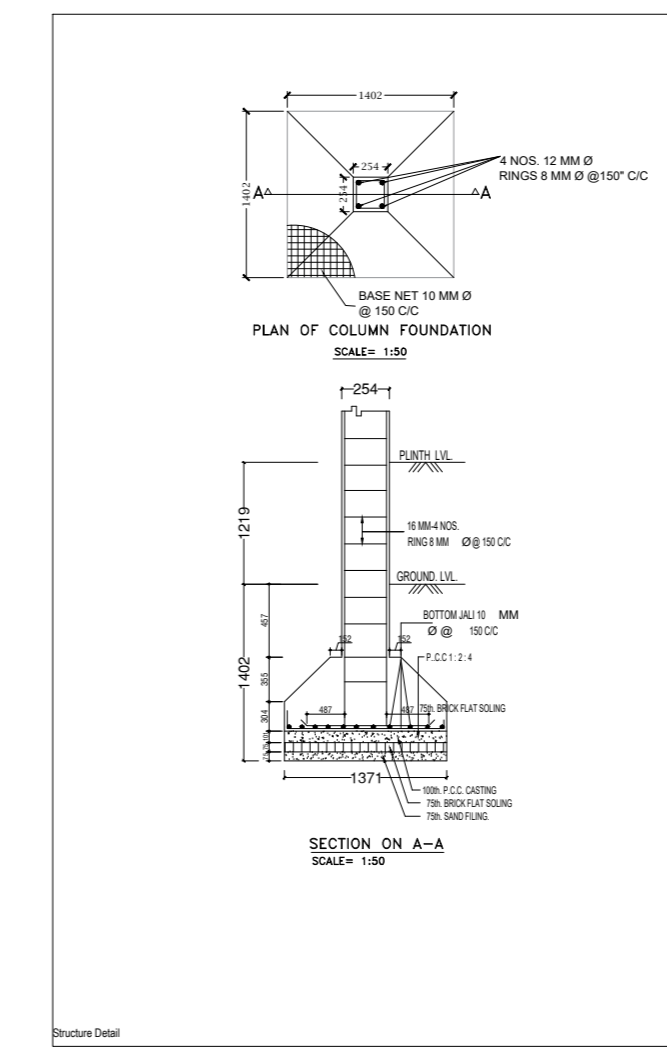
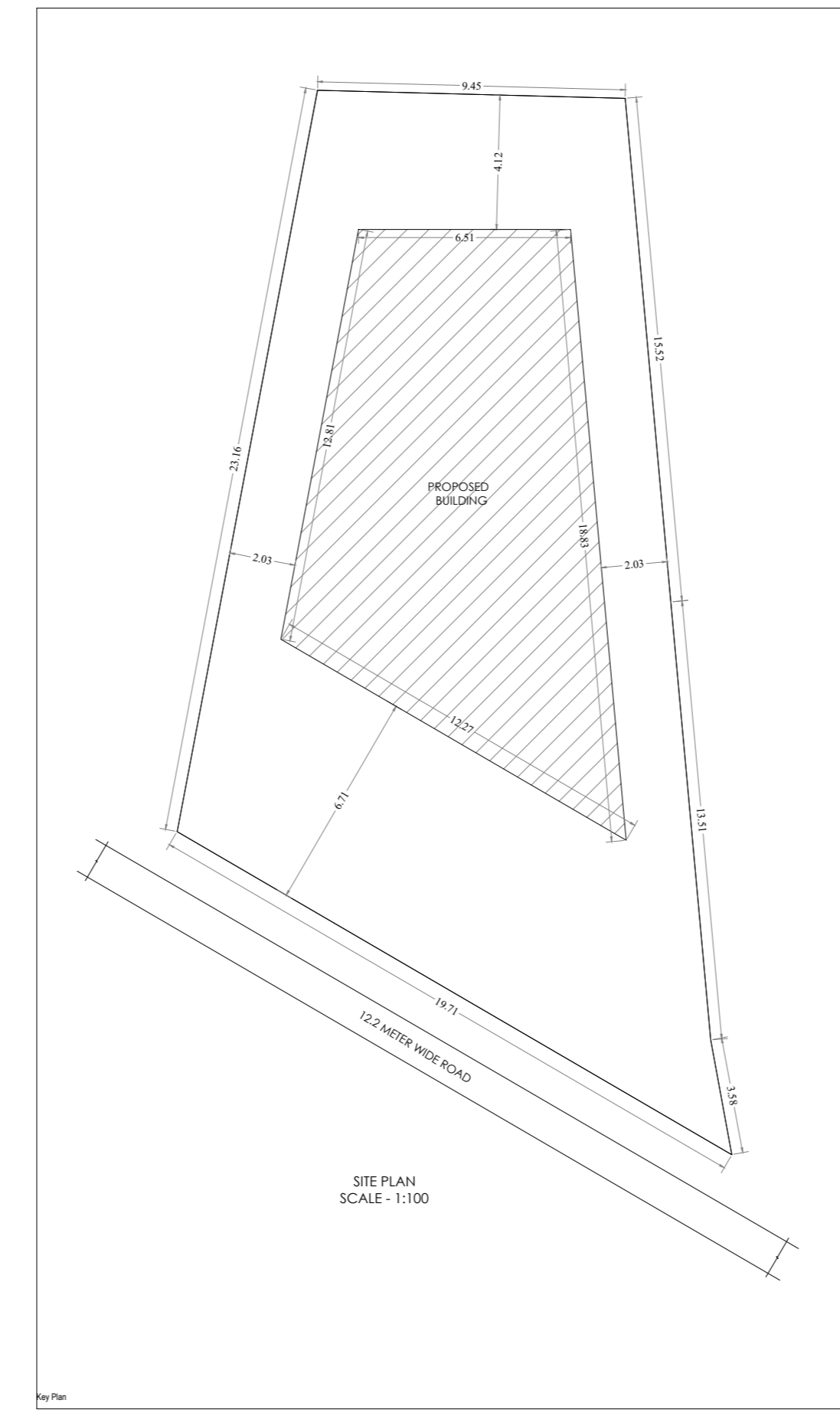
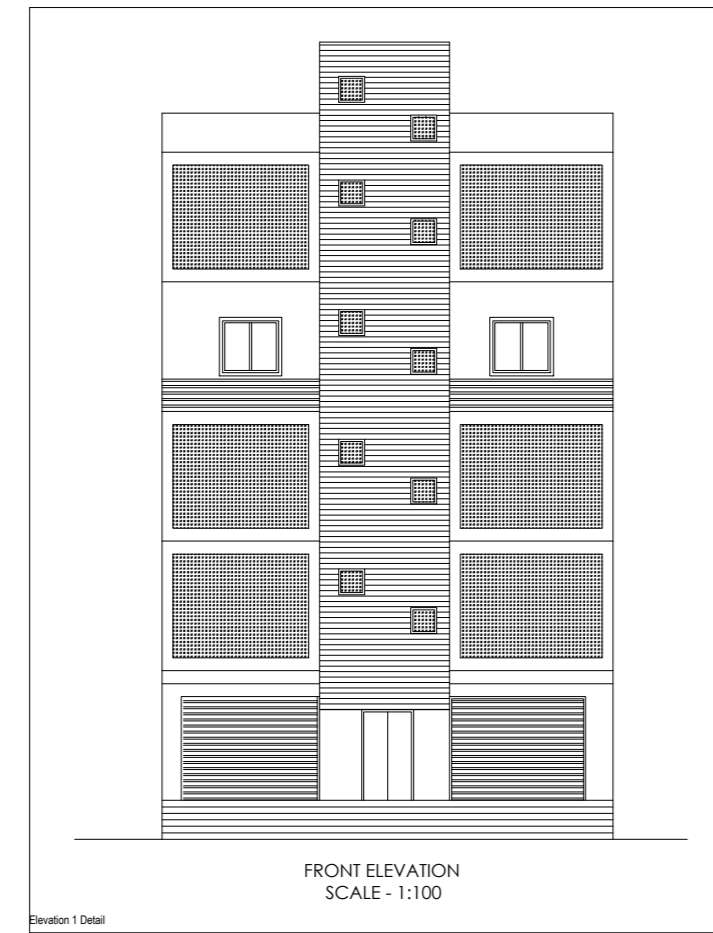
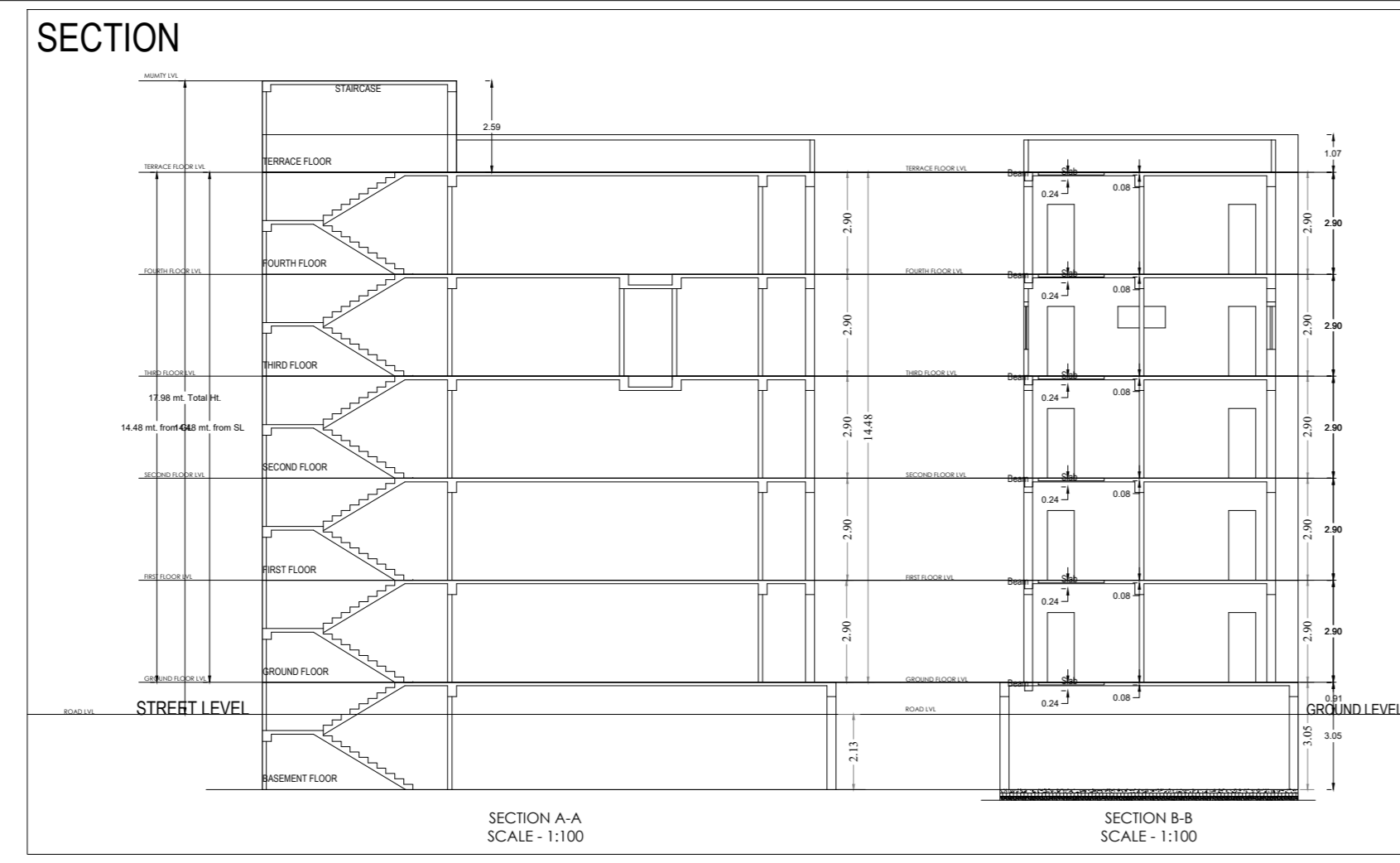

**Building A RAJESH KUMAR AND SWETA KESHRI**

Floor Name	Area (Sq. M)	Volume (Cu. M)	Perimeter (M)	Area (Sq. M)	Volume (Cu. M)	Perimeter (M)	Area (Sq. M)	Volume (Cu. M)	Perimeter (M)
Basement	100.00	100.00	100.00	100.00	100.00	100.00	100.00	100.00	100.00
Ground Floor	100.00	100.00	100.00	100.00	100.00	100.00	100.00	100.00	100.00
First Floor	100.00	100.00	100.00	100.00	100.00	100.00	100.00	100.00	100.00
Second Floor	100.00	100.00	100.00	100.00	100.00	100.00	100.00	100.00	100.00
Third Floor	100.00	100.00	100.00	100.00	100.00	100.00	100.00	100.00	100.00
Fourth Floor	100.00	100.00	100.00	100.00	100.00	100.00	100.00	100.00	100.00
Terrace	100.00	100.00	100.00	100.00	100.00	100.00	100.00	100.00	100.00
Total	500.00	500.00	500.00	500.00	500.00	500.00	500.00	500.00	500.00

**SCHEDULE OF JOINERY**

ITEM	QTY	UNIT	REMARKS
1. DOOR	10	NO	1.50 x 2.10
2. WINDOW	20	NO	1.50 x 1.50
3. SHUTTER	10	NO	1.50 x 1.50
4. ROLLING SHUTTER	10	NO	1.50 x 1.50

**SCHEDULE OF JOINERY**

ITEM	QTY	UNIT	REMARKS
1. DOOR	10	NO	1.50 x 2.10
2. WINDOW	20	NO	1.50 x 1.50
3. SHUTTER	10	NO	1.50 x 1.50
4. ROLLING SHUTTER	10	NO	1.50 x 1.50

**Legend Table for Building A RAJESH KUMAR AND SWETA KESHRI**

ITEM	QTY	UNIT	REMARKS
1. DOOR	10	NO	1.50 x 2.10
2. WINDOW	20	NO	1.50 x 1.50
3. SHUTTER	10	NO	1.50 x 1.50
4. ROLLING SHUTTER	10	NO	1.50 x 1.50

**PROJECT SUMMARY**

ITEM	DESCRIPTION	QUANTITY	UNIT	REMARKS
1	CONCRETE	1000	CUM	
2	BRICKS	10000	NO	
3	ROOFING	1000	SQ. M	
4	PAINTING	1000	SQ. M	
5	WATER SUPPLY	1000	LITERS	
6	SEWERAGE	1000	LITERS	
7	ELECTRICITY	1000	AMPS	
8	TELEPHONE	1000	AMPS	
9	TELEVISION	1000	AMPS	
10	REFRIGERATION	1000	AMPS	
11	AIR CONDITIONING	1000	AMPS	
12	LIFT	1000	AMPS	
13	WATER HEATING	1000	AMPS	
14	WATER PUMPING	1000	AMPS	
15	WATER TREATMENT	1000	AMPS	
16	WATER STORAGE	1000	AMPS	
17	WATER DISTRIBUTION	1000	AMPS	
18	WATER CONSUMPTION	1000	AMPS	
19	WATER WASTEWATER	1000	AMPS	
20	WATER REUSE	1000	AMPS	

**COLOR INDEX**

COLOR	DESCRIPTION
1	CONCRETE
2	BRICKS
3	ROOFING
4	PAINTING
5	WATER SUPPLY
6	SEWERAGE
7	ELECTRICITY
8	TELEPHONE
9	TELEVISION
10	REFRIGERATION
11	AIR CONDITIONING
12	LIFT
13	WATER HEATING
14	WATER PUMPING
15	WATER TREATMENT
16	WATER STORAGE
17	WATER DISTRIBUTION
18	WATER CONSUMPTION
19	WATER WASTEWATER
20	WATER REUSE

**PARKING CALCULATION**

Category	Area (Sq. M)	Capacity
Car	1000	100
Two Wheeler	1000	100
Auto Rickshaw	1000	100
Motorcycle	1000	100
Tricycle	1000	100
Other	1000	100
Total	6000	600

**MATERIAL DETAIL**

Material	Quantity	Unit	Remarks
Concrete	1000	CUM	
Bricks	10000	NO	
Roofing	1000	SQ. M	
Painting	1000	SQ. M	
Water Supply	1000	LITERS	
Sewerage	1000	LITERS	
Electricity	1000	AMPS	
Telephone	1000	AMPS	
Television	1000	AMPS	
Refrigeration	1000	AMPS	
Air Conditioning	1000	AMPS	
Lift	1000	AMPS	
Water Heating	1000	AMPS	
Water Pumping	1000	AMPS	
Water Treatment	1000	AMPS	
Water Storage	1000	AMPS	
Water Distribution	1000	AMPS	
Water Consumption	1000	AMPS	
Water Wastewater	1000	AMPS	
Water Reuse	1000	AMPS	

**PAR & Transport Details (Table No. 1)**

Category	Area (Sq. M)	Capacity
Car	1000	100
Two Wheeler	1000	100
Auto Rickshaw	1000	100
Motorcycle	1000	100
Tricycle	1000	100
Other	1000	100
Total	6000	600