

Proposal Basic Information	
Proposal File No.	LNP/BI/0030/W13/2021
Owner Name	ALTAMASH AFRIDI
Khata No	114
Plot No	623
Village Name	Nadia
Use	Residential
SubUse	Bungalow/ Dwelling / Non Apartment

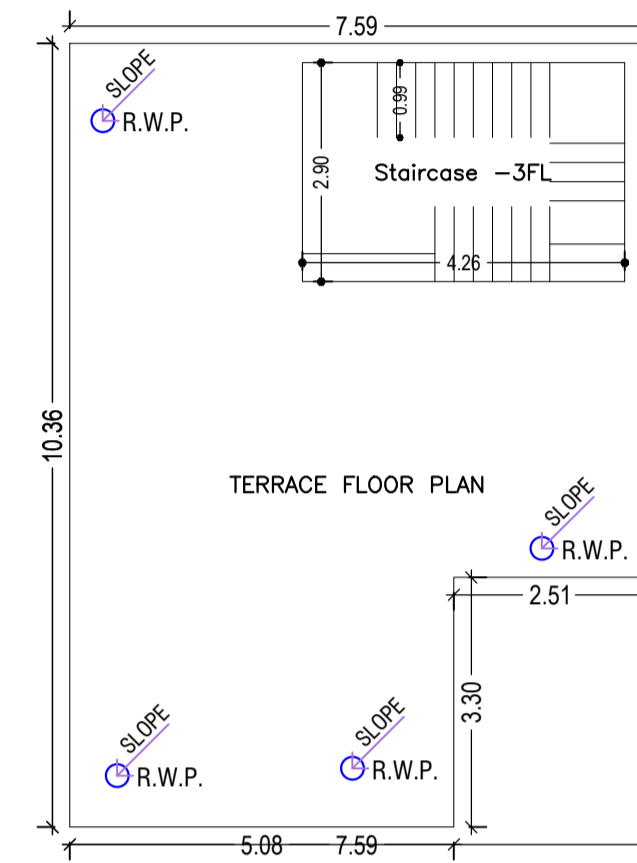
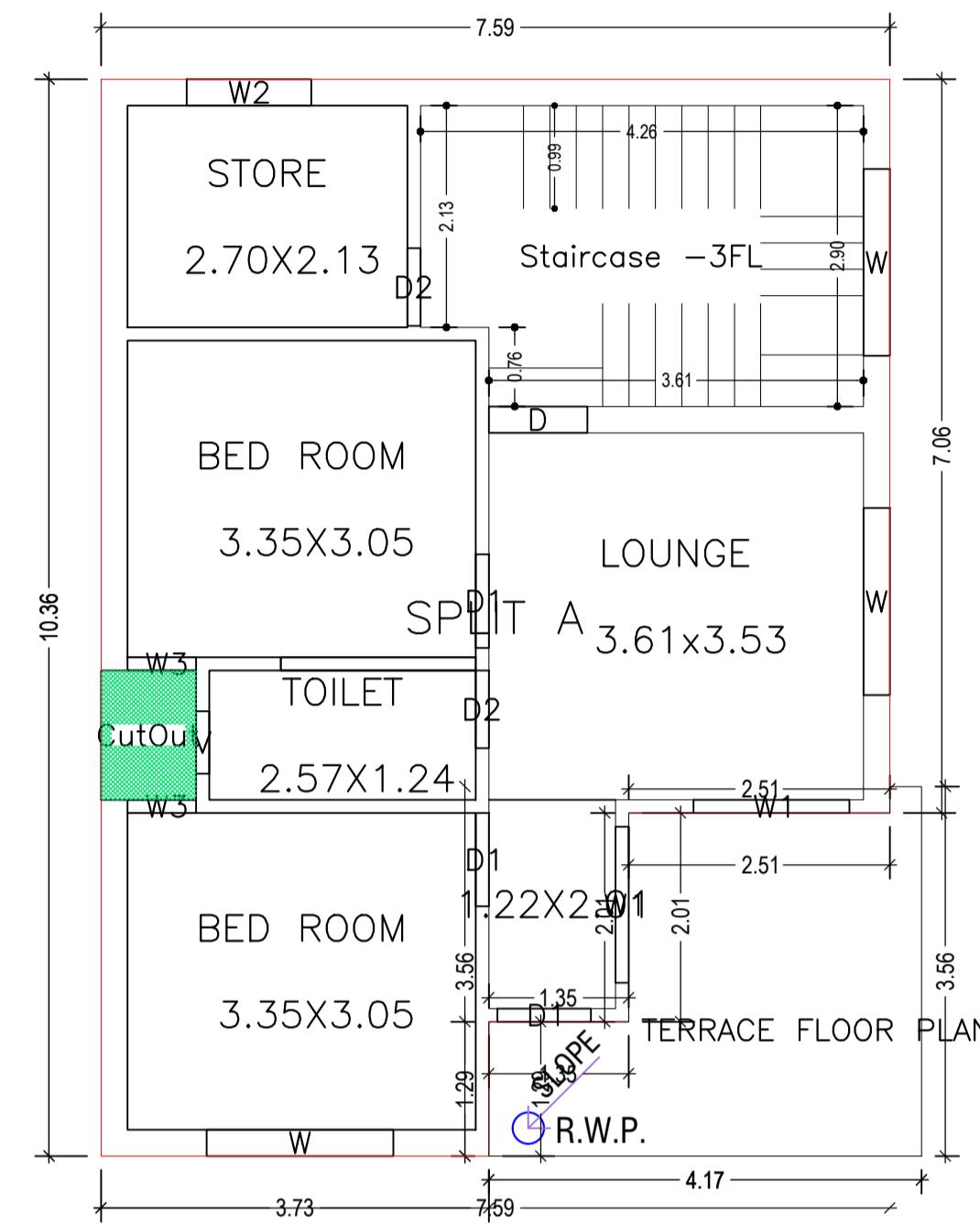
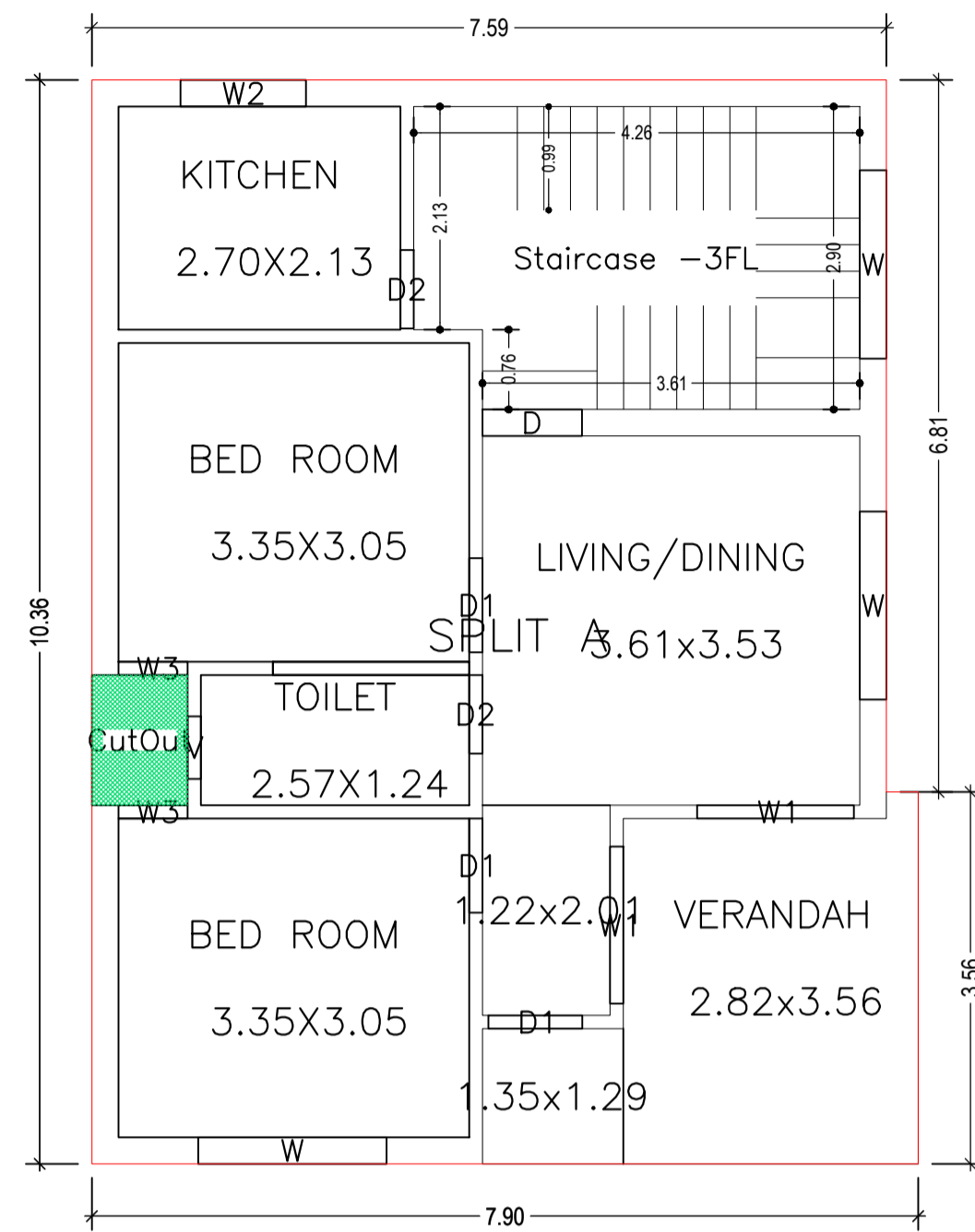

SCHEDULE OF DOOR:

BUILDING NAME	NAME	LENGTH	HEIGHT	NOS
A (ALTAMASH AFRIDI)	D2	0.75	2.13	04
A (ALTAMASH AFRIDI)	D1	0.90	2.13	06
A (ALTAMASH AFRIDI)	D	0.95	2.13	02

SCHEDULE OF WINDOW/VENTILATION:

BUILDING NAME	NAME	LENGTH	HEIGHT	NOS
A (ALTAMASH AFRIDI)	V	0.60	2.70	02
A (ALTAMASH AFRIDI)	W3	0.66	2.70	04
A (ALTAMASH AFRIDI)	W2	1.20	2.70	02
A (ALTAMASH AFRIDI)	W1	1.50	2.70	04
A (ALTAMASH AFRIDI)	W	1.80	2.70	06

Building :A (ALTAMASH AFRIDI)

Floor Name	Gross Builtup Area	Deductions From Gross BUA/Area in Sq.mt.)	Total Built Up Area (Sq.mt.)	Proposed FAR Area (Sq.mt.)	Total FAR Area (Sq.mt.)	Total Consumed Additional FAR Area (Sq.mt.)	Tnmt (No.)
Ground Floor	79.79	1.14	78.65	78.65	78.65	78.65	01
First Floor	68.66	1.14	67.52	67.52	67.52	67.52	00
Terrace Floor	0.00	0.00	0.00	0.00	0.00	0.00	00
Total	148.45	2.28	146.17	146.17	146.17	146.17	01
Total Number of Same Buildings	1						
Total :	148.45	2.28	146.17	146.17	146.17	146.17	01

UnitBUA Table for Building :A (ALTAMASH AFRIDI)

FLOOR	Name	UnitBUA Type	UnitBUA Area	Carpet Area	No. of Rooms	No. of Tenement
GROUND FLOOR PLAN	SPLIT A	FLAT	104.58	104.10	6	1
FIRST FLOOR PLAN	SPLIT A	FLAT	0.00	0.00	5	0
Total:	-	-	104.58	104.10	11	1

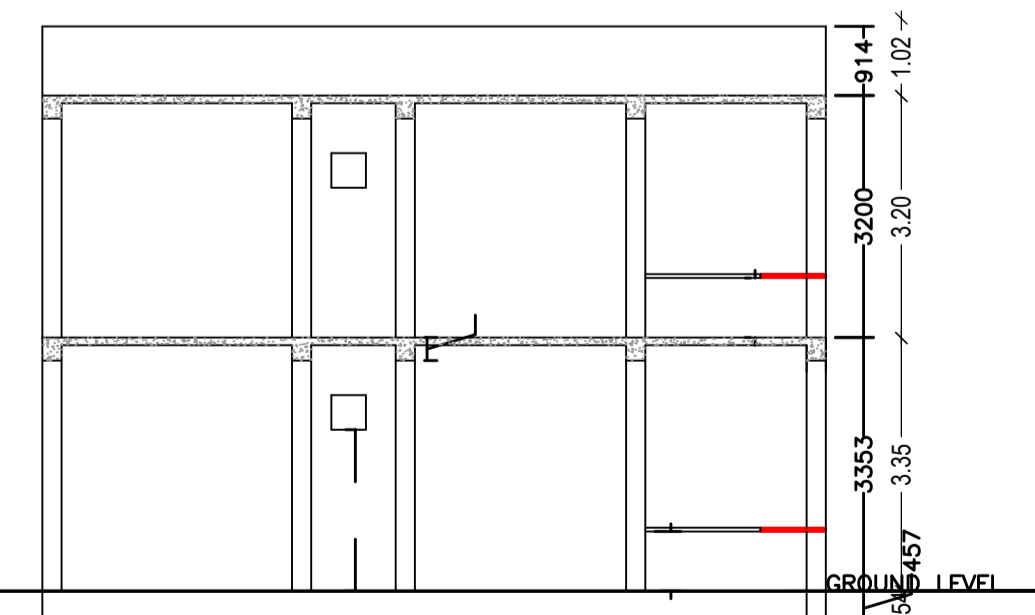
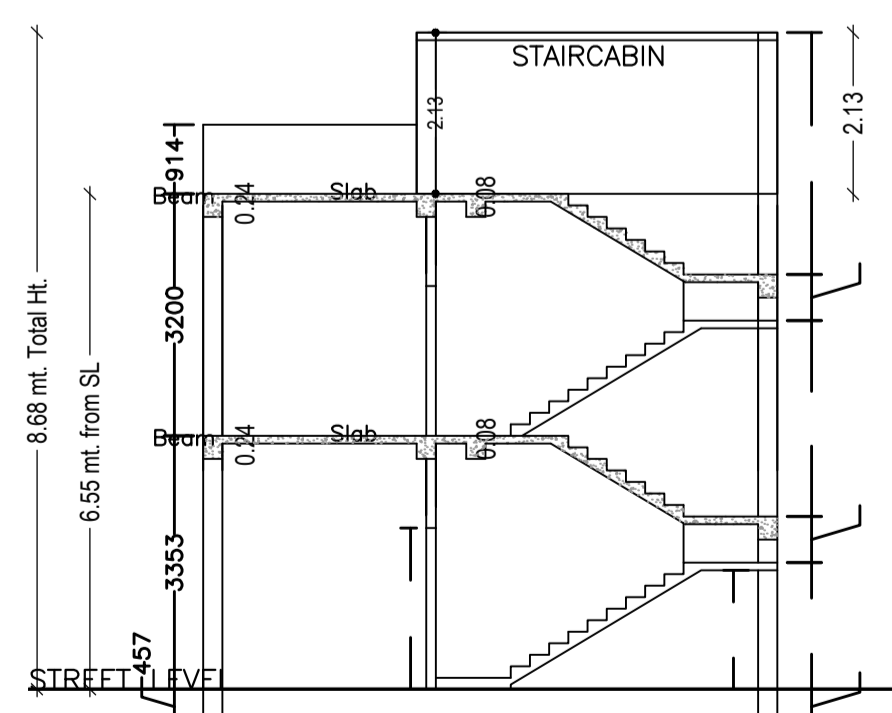

LTP NAME AND SIGNATURE	STRUCTURAL ENG'S NAME AND SIGNATURE	BUILDER NAME AND SIGNATURE	DIGITAL SIGNATURE
SUNIL KUMAR LNP/ENG/0004/2017			

Proposal Basic Information	
Proposal File No.	LNP/BI/0030/W13/2021
Owner Name	ALTAMASH AFRIDI
Khata No	114
Plot No	623
Village Name	Nadia
Use	Residential
SubUse	Bungalow/ Dwelling / Non Apartment

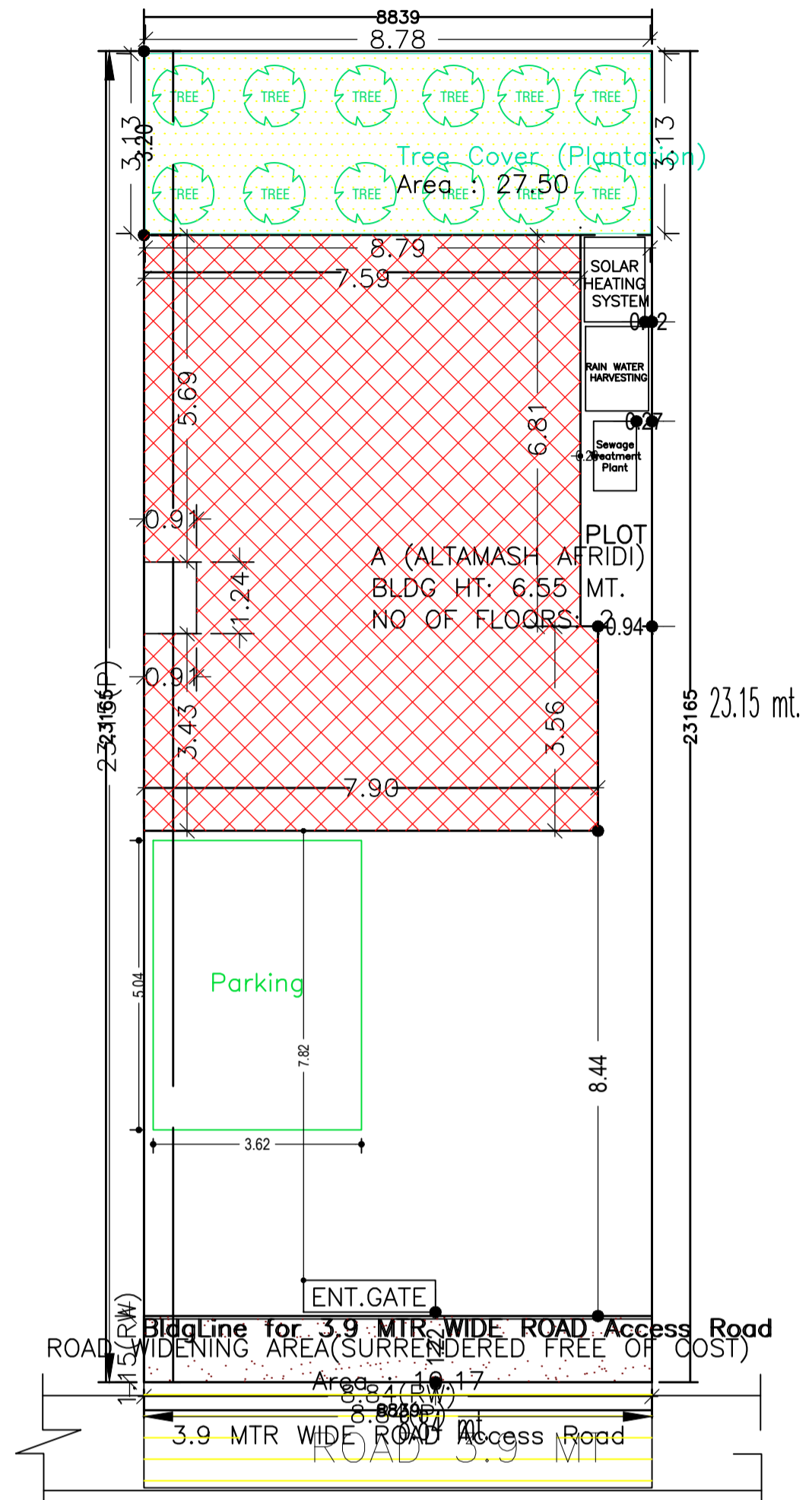

SITE PLAN  
Scale - 1:100  
SITE PLAN

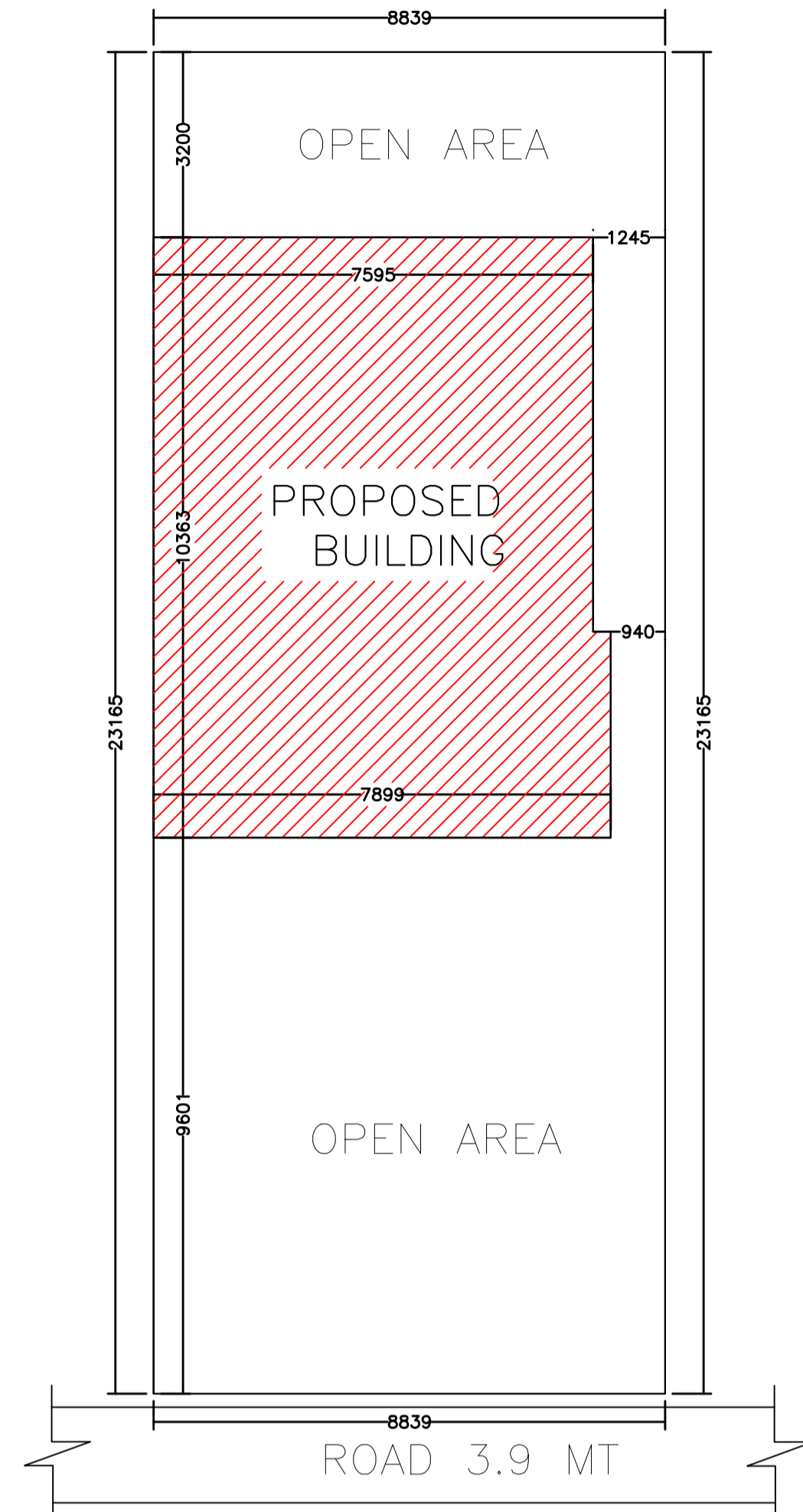

SITE PLAN  
Scale - 1:100

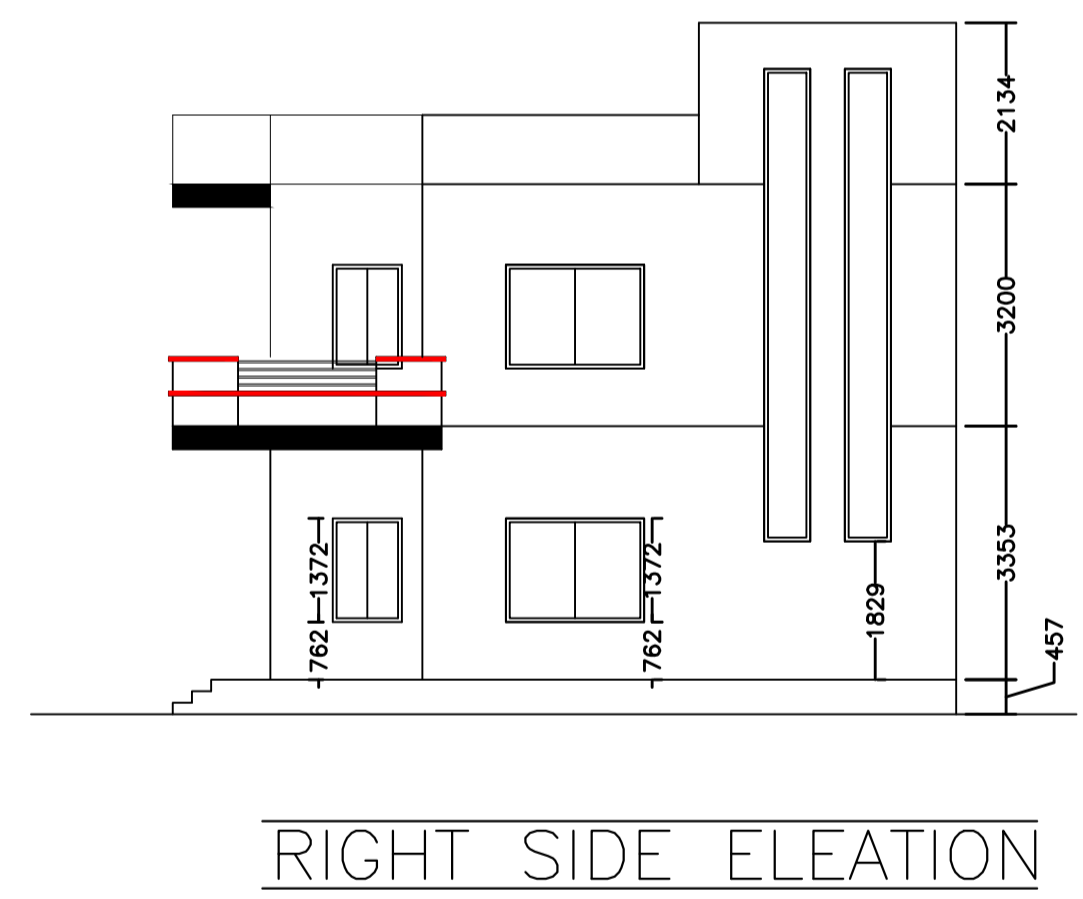
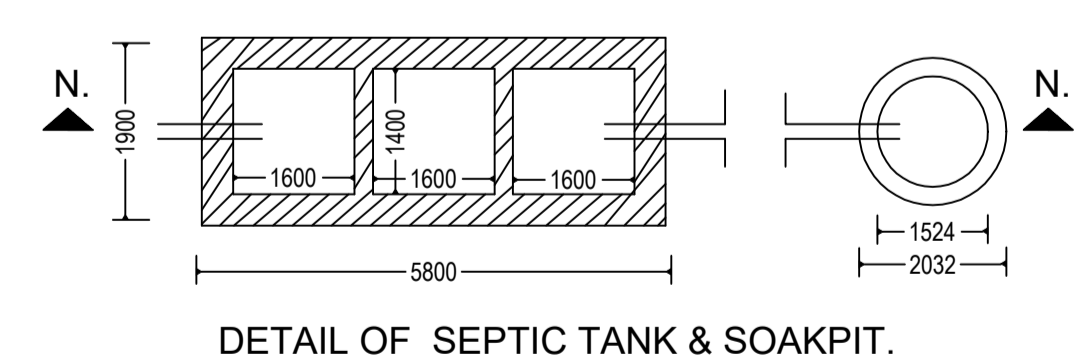
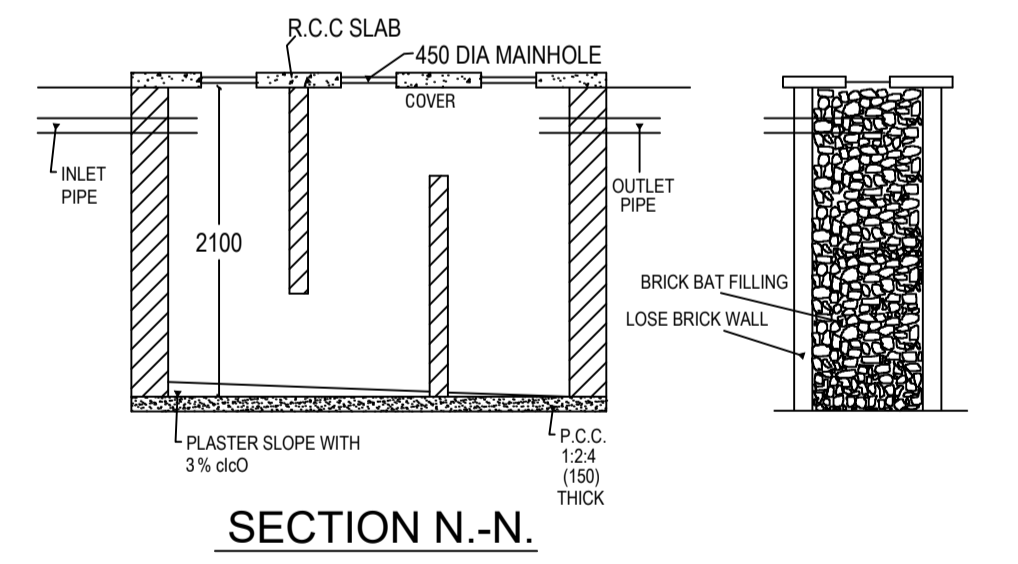
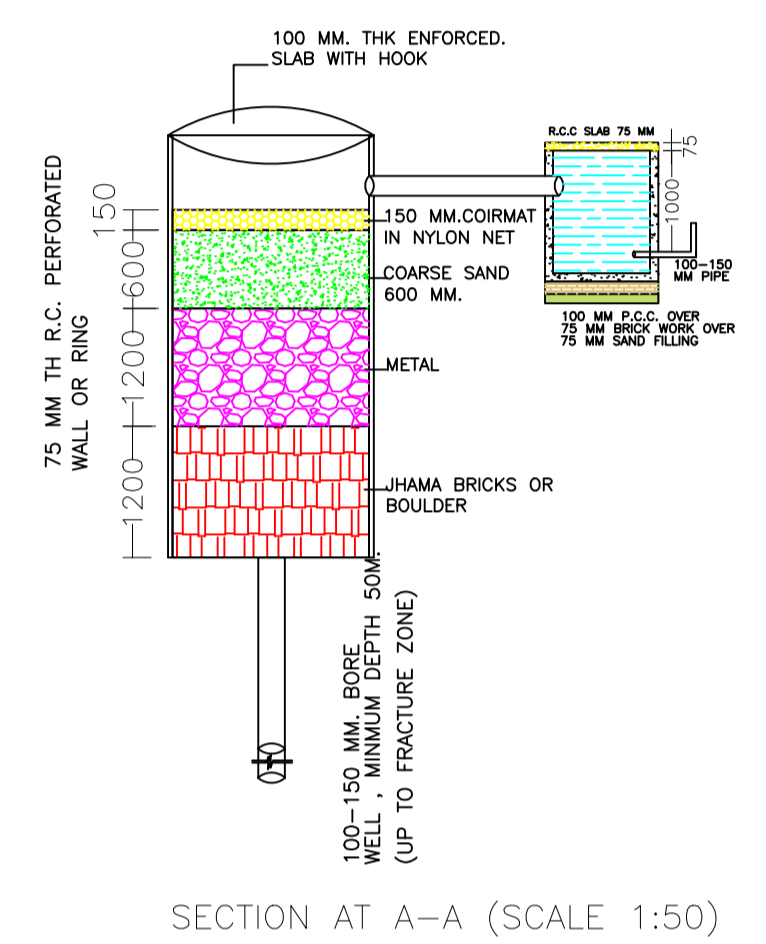
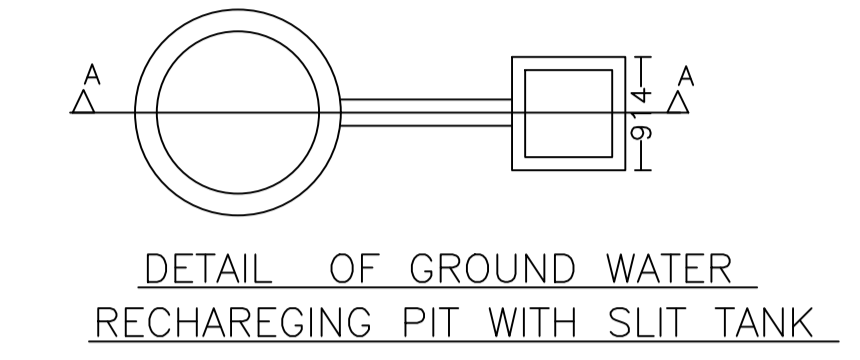
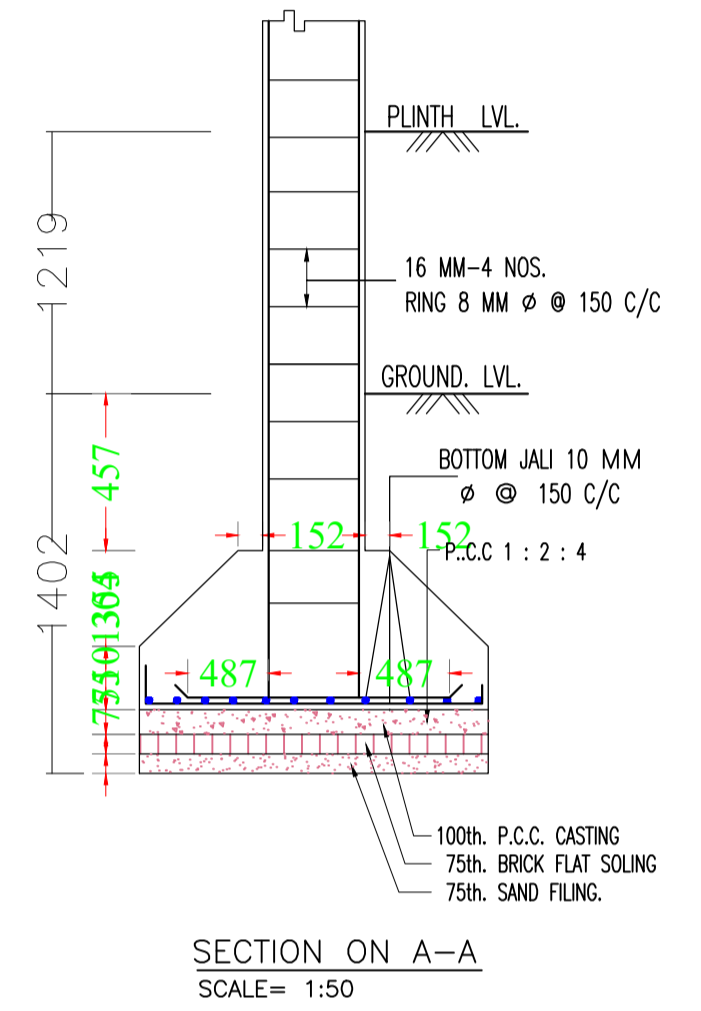
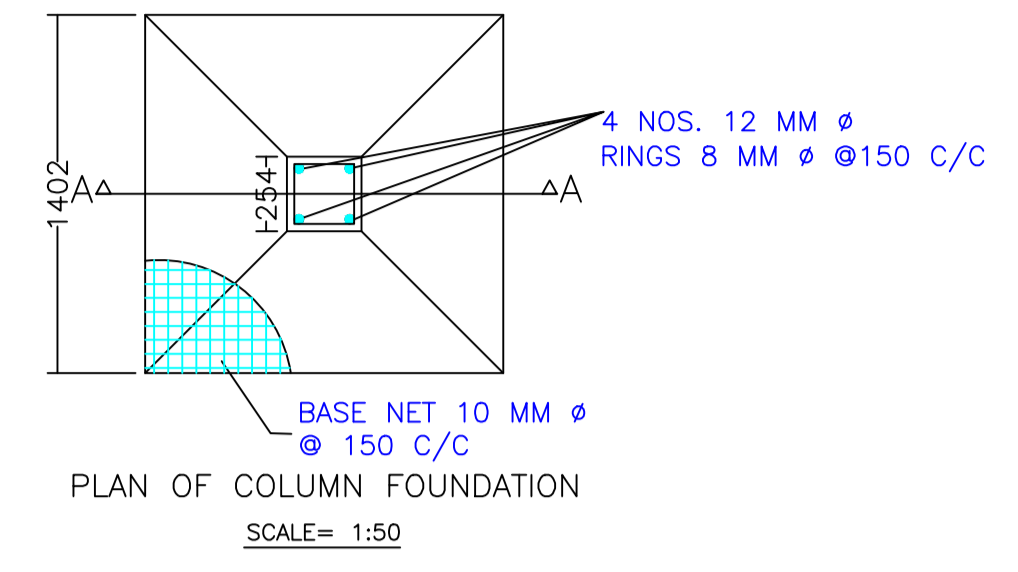

AREA STATEMENT		VERSION NO. : 1.0.60
LOHARDAGA NAGAR PARISHAD		VERSION DATE: 16/10/2020
PROJECT DETAIL:		
Region: JHARKHAND URBAN LOCAL BODIES	Plot Use: Residential	
District: LOHARDAGA	Plot SubUse: Bungalow/ Dwelling / Non Apartment	
Authority: LOHARDAGA NAGAR PARISHAD	PlotNearby/ReligiousStructure: NA	
Inward No: LNP/BI/0030/W13/2021	Plot/SubPlot No: 623	
Application Type: General Proposal	North: -	
Project Type: BUILDING PERMISSION	South: -	
Nature of Development: New	East: -	
Location of Development Area: Old Area	West: Road Width - 3.90 MTR WIDE MAIN ROAD	
AREA DETAILS:		
AREA OF PLOT (Minimum)	(A)	SQ.MT. 204.67
Deduction for NetPlot Area		
Surrender Free of Cost		10.17
Total		10.17
NET AREA OF PLOT(Gross Plot Area - Deduction from Gross Plot area)	(A-Deductions)	194.50
Deduction for Balance Plot Area(from Gross Plot Area)		
Surrender Free of Cost		10.17
Common Plot		27.50
Total		37.67
BALANCE AREA OF PLOT(Net Plot Area - Recreational/Amenity space)	(A-Deductions)	167.00
PLOT AREA FOR COVERAGE(Net Plot Area)	(A-Deductions)	194.50
Plot Area for FAR (Net Plot Area + RoadWidening Area)	(A-Deductions)	204.67
COVERAGE CHECK		
Permissible Coverage area ( 70.00 % )		136.15
Proposed Coverage Area ( 40.44 % )		78.65
Total Prop. Coverage Area ( 40.44 % )		78.65
Balance coverage area ( 29.56 % )		57.50
FAR CHECK		
Perm. FAR Area ( 1.50 )		307.01
Total Perm. FAR area		307.01
Residential FAR		146.17
Proposed FAR Area		146.17
Total Proposed FAR Area		146.17
Consumed FAR (Factor)		0.71
Balance FAR Area		160.84
BUILT UP AREA CHECK		
Total Proposed BuiltUp Area		146.17
ARCHITECT (Regd)	SUNIL KUMAR	
ENGINEER (Regd)		
SUPERVISOR (Regd)		
OWNER (Regd)	ALTAMASH AFRIDI	
DEVELOPMENT AUTHORITY	LOCAL BODY	

FAR & Tenement Details (Table 4c-1)

Building	No. of Same Bldg	Gross Built Up Area (Sq.mt.)	Deductions From Gross BUA/Area in Sq.mt. Cutout	Total Built Up Area (Sq.mt.)	Proposed FAR Area (Sq.mt.)	Total FAR Area (Sq.mt.)	Total Consumed Additional FAR Area (Sq.mt.)	Tnmt (No.)
A (ALTAMASH AFRIDI)	1	148.45	2.28	146.17	146.17	146.17	146.17	01
Grand Total :	1	148.45	2.28	146.17	146.17	146.17	146.17	01

Buildingwise Floor FAR Details

Floor Name	Building Name A (ALTAMASH AFRIDI)		Total	
	Proposed Built Up Area (Sq.mt.)	Proposed FAR Area (Sq.mt.)	Total Proposed Built Up Area (Sq.mt.)	Total FAR Area (Sq.mt.)
Ground Floor	78.65	78.65	78.65	78.65
First Floor	67.52	67.52	67.52	67.52
Terrace Floor	0.00	0.00	0.00	0.00
Total :	146.17	146.17	146.17	146.17

Building USE/SUBUSE Details

Building Name	Building Use	Building SubUse	Building Structure
A (ALTAMASH AFRIDI)	Residential	Bungalow/ Dwelling / Non Apartment	Non-Highrise

COLOR INDEX	
PLOT BOUNDARY	[Red Line]
ABUTTING ROAD	[Green Line]
PROPOSED CONSTRUCTION	[Blue Line]
COMMON PLOT	[Yellow Line]
ROAD WIDENING AREA	[Orange Line]
EXISTING (To be retained)	[Black Line]
EXISTING (To be demolished)	[Blue Line]

LTP NAME AND SIGNATURE	STRUCTURAL ENG'S NAME AND SIGNATURE	BUILDER NAME AND SIGNATURE	DIGITAL SIGNATURE
SUNIL KUMAR LNP/ENG/0004/2017			