

Project Title :G+2 residential building

<b>AREA STATEMENT OVERMADGA MARGA PANGRAJ</b>		VERSION NO. 1.0.20
<b>PROJECT DETAILS</b>		LOCATION/DATE: 16/10/2020
Project No.:		Plot Use: Residential
Design: UNIVARND (URBAN LOCAL CODE)		Plot No.: 2796
Client: UJJWAL KUMAR AGRAWAL		Land Use Zone: 100
Preparation Type: General Purpose		Planning Area Code: -
Project Type: Working Permission		Plot No.: -
Title of Development: New		Planning Survey No/Zone No: -
Location: OR Area		Thana No.: -
Plot Category: 100		Plot No.: -
Valid/Issue Name		Issue No.: -
Issue Date:		Issue Date: -
Scale/Level:		Scale: -
		Level: -

FLOOR AREA		
Floor No.	Area (Sq. Mtr)	Area (Sq. Ft)
1st Floor	111.29	1203.27
2nd Floor	111.29	1203.27
Total	222.58	2406.54

COLOR INDEX		
Color	Description	Code
White	Walls, Ceiling	01
Grey	Walls, Ceiling	02
Light Blue	Walls, Ceiling	03

MARGIN DETAIL					
Building / Wing	Road Name	Front Margin	Rear Margin	Side Margin	Side Margin
A (BUILDING)	TERMINUS ROAD	3.00	3.00	0.00	1.00

FAR & Terment Details (Table 4c-1)			
Building	No. of Same Bldg	Total Built up Area (Sq. Mtr)	Proposed FAR Area (Sq. Mtr)
A (BUILDING)	1	111.29	111.29
Total	1	111.29	111.29

**SECTION - B-B**, **SECTION - A-A**

**GROUND FLOOR PLAN** (SCALE: 1:100)

**FIRST FLOOR PLAN** (SCALE: 1:100)

**SECOND FLOOR PLAN** (SCALE: 1:100)

**SOUTH SIDE ELEVATION**, **EAST SIDE ELEVATION**

**DETAILS OF FOOTING & COLUMN** (SCALE: 1:200)

**DETAILS OF GROUND WATER RECHARGING PIT WITH SILT TANK**

**DETAILS OF SEPTIC TANK(20 USER)**

**RAIN WATER HARVESTING**

**APP PLOT**, **GUMLA ROAD 10.6 M WIDE**

**SPECIFICATION**

- FOUNDATION: REINFORCED CONCRETE WITH GRAVEL FOOTING OF 150 MM TO 200 MM DEPTH.
- DOOR: 1800 MM HIGH x 1000 MM WIDE.
- WINDOW: 1800 MM HIGH x 1200 MM WIDE.
- ROOF: 100 MM PCC, 100 MM SAND, 100 MM PCC.
- WALL: 200 MM THICK REINFORCED CONCRETE.
- PLASTER: 12 MM THICK M/S P.
- DOOR: 1000 MM HIGH x 1000 MM WIDE.
- WINDOW: 1800 MM HIGH x 1200 MM WIDE.
- WINDSHIELD: 1000 MM HIGH x 1000 MM WIDE.
- WINDSHIELD: 1000 MM HIGH x 1000 MM WIDE.
- ELECTRICAL: CONCEALED WITH COPPER CONDUCTOR.
- WATER SUPPLY: THROUGH SILENT PIPE.
- EXTERNAL FINISH: OIL BOND DISTEMPER ON TOP.
- EXTERNAL FINISH: OIL BOND DISTEMPER ON TOP.
- EXTERNAL FINISH: OIL BOND DISTEMPER ON TOP.

**AREA CALCULATION: (FOR THE PROPOSED BUILDING)**

Plot Area: 111.29 SQ. M

Built up Area:

- Proposed Ground Floor: 59.14 SQ. M
- Proposed First Floor: 60.15 SQ. M
- Total: 119.29 SQ. M

% OF COVERED AREA: 107.11%

**PROPOSED RESIDENTIAL BUILDING**  
 OF (1) UJJWAL KUMAR AGRAWAL (2) UJJWAL KUMAR AGRAWALS/O KANHAYA LAL AGRAWAL IN M/S. PLOT NO. 2796 82797. AT VILLAGE -GUMLA ROAD (I) DITHANA NO -194, WARD NO -18, THANA & DIST -LOHARDAGA.

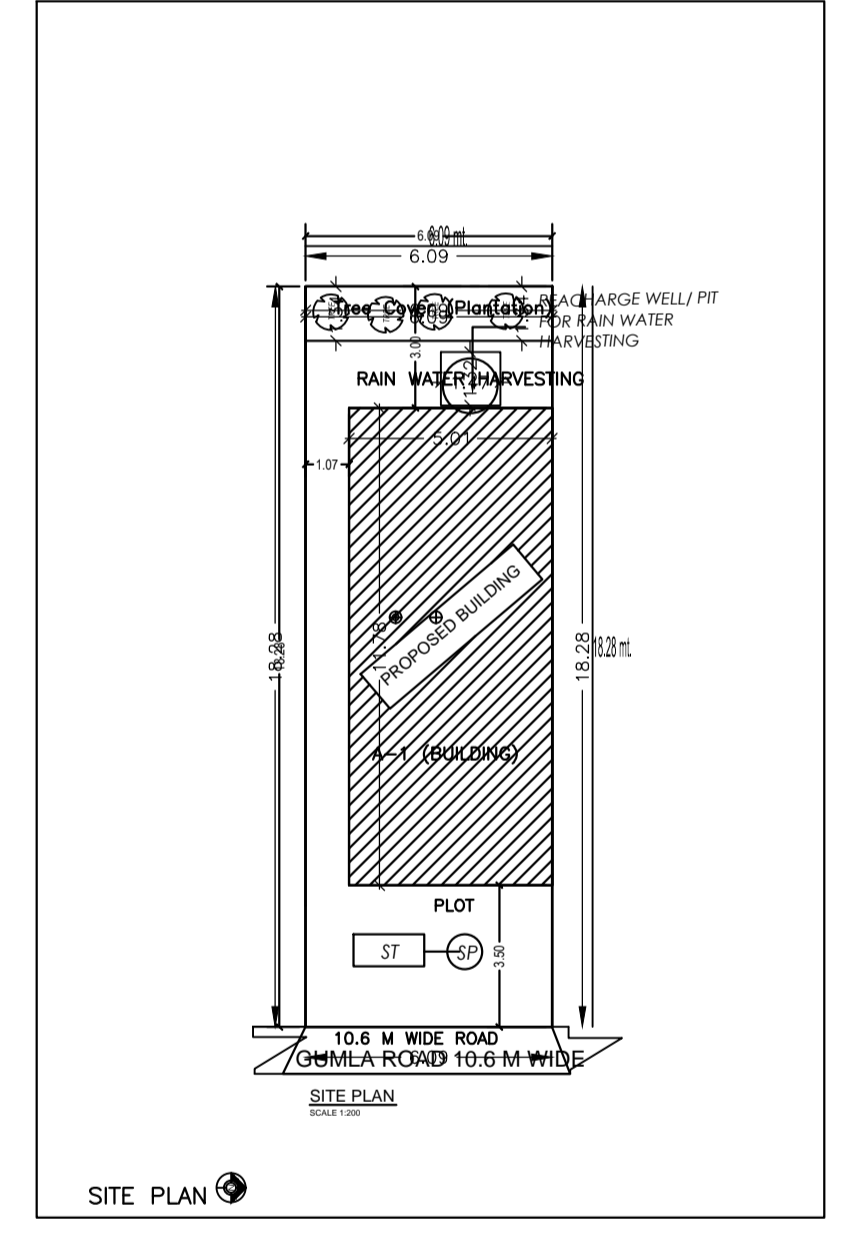

A. (BUILDING)

**Building A (BUILDING)**

Floor Name	Total Built up Area (Sq. Mtr)	Proposed FAR Area (Sq. Mtr)	Total FAR Area (Sq. Mtr)	Term (Nos)
Ground Floor	59.14	59.14	59.14	01
1st Floor	60.15	60.15	60.15	01
Total	119.29	119.29	119.29	02

**SCHEDULE OF JONERY**

ITEM NAME	NAME	LENGTH	HEIGHT	NO. OF
P. BUILDING	P	0.75	2.10	03
	W	2.20	1.20	03
	D	1.00	2.10	01
	T	1.00	2.10	01

**UNDERLAY Table for Building A (BUILDING)**

FLOOR	Name	STRIP/FLAT	INSTR. AREA	COVER. AREA	No. of Rooms	No. of Terment
GROUND	APU 1	FLAT	108.58	107.96	2	1
SUBTOTAL	-	-	108.58	107.96	02	1
Total	-	-	108.58	107.96	02	1