

Proposal Basic Information	
Proposal File No.	LNP/BP/0064/W22/2021
Owner Name	SUDARSAN PRASAD
Khata No	494
Plot No	3583
Village Name	Badla
Use	Residential
SubUse	Bungalow/ Dwelling / Non Apartment

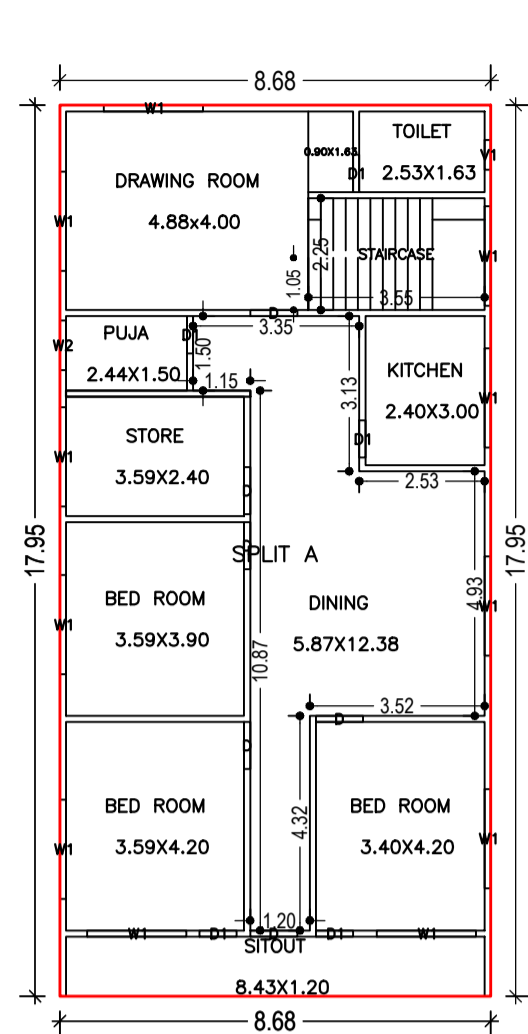

FIRST FLOOR PLAN (Proposed) (SCALE 1:100)

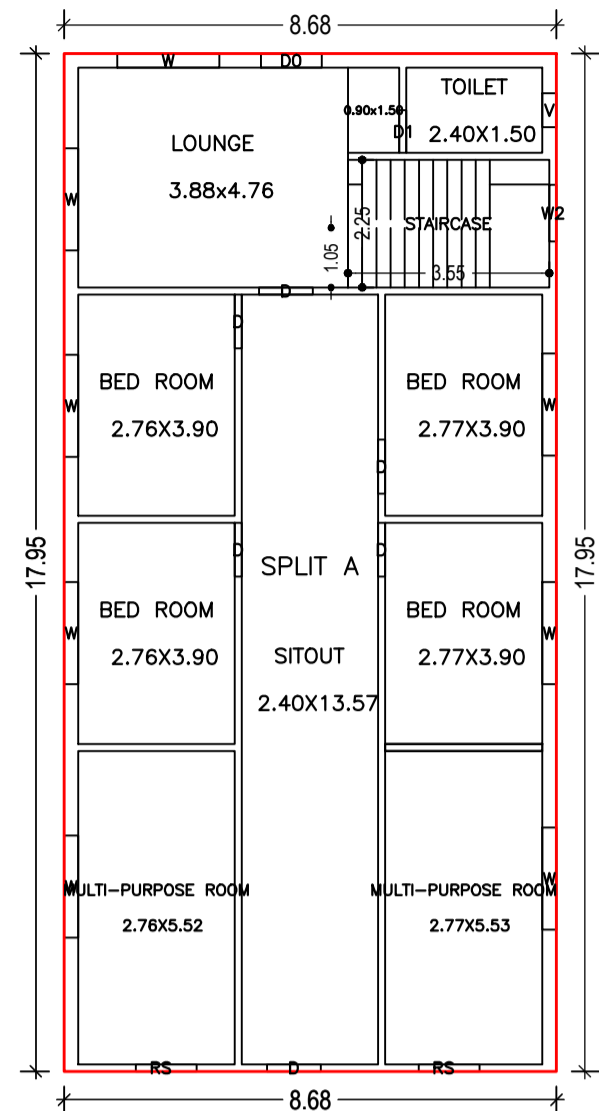

GROUND FLOOR PLAN (Proposed) (SCALE 1:100)

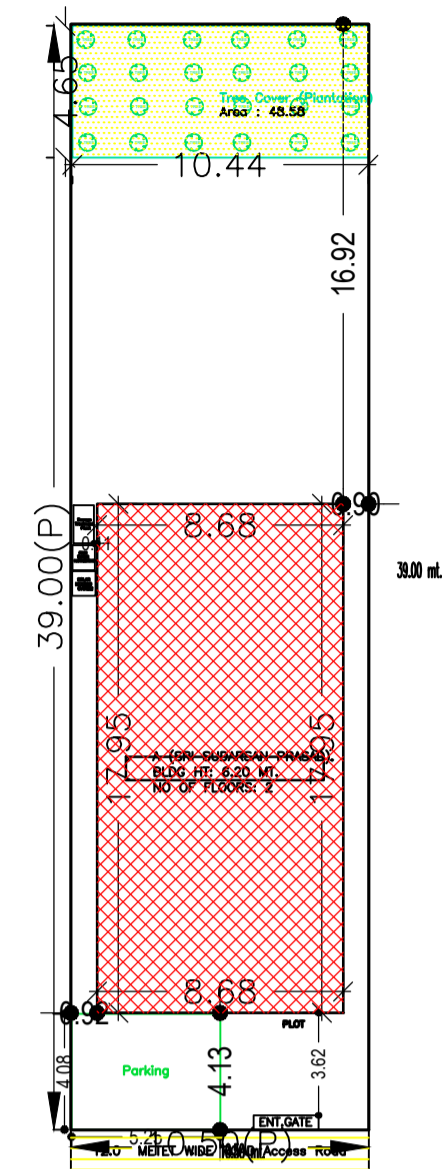

SITE PLAN

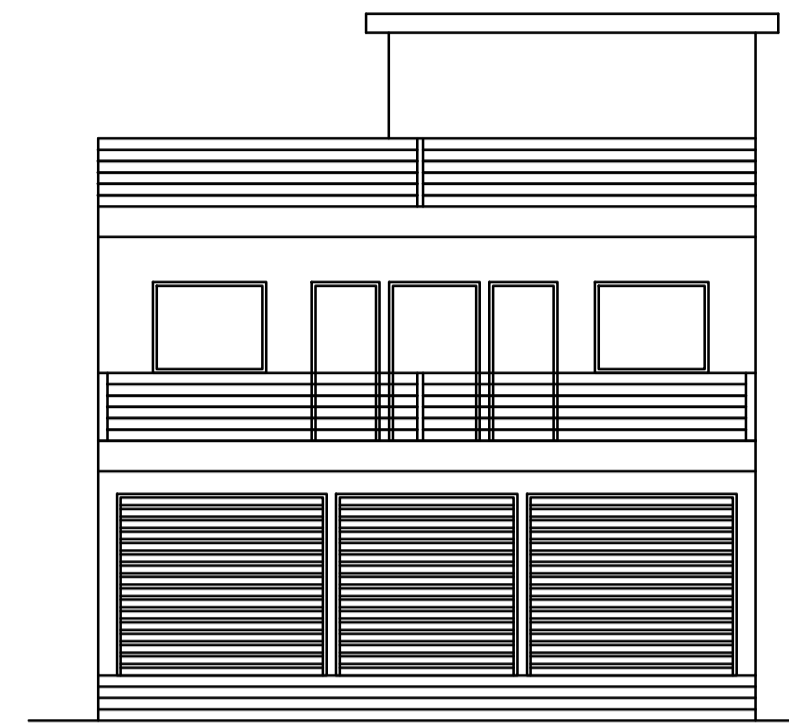

FRONT ELEVATION (SCALE - 1:100)

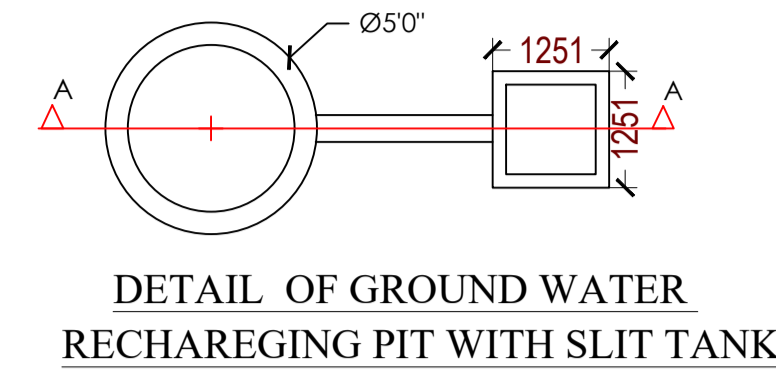

DETAIL OF GROUND WATER RECHARGING PIT WITH SLIT TANK

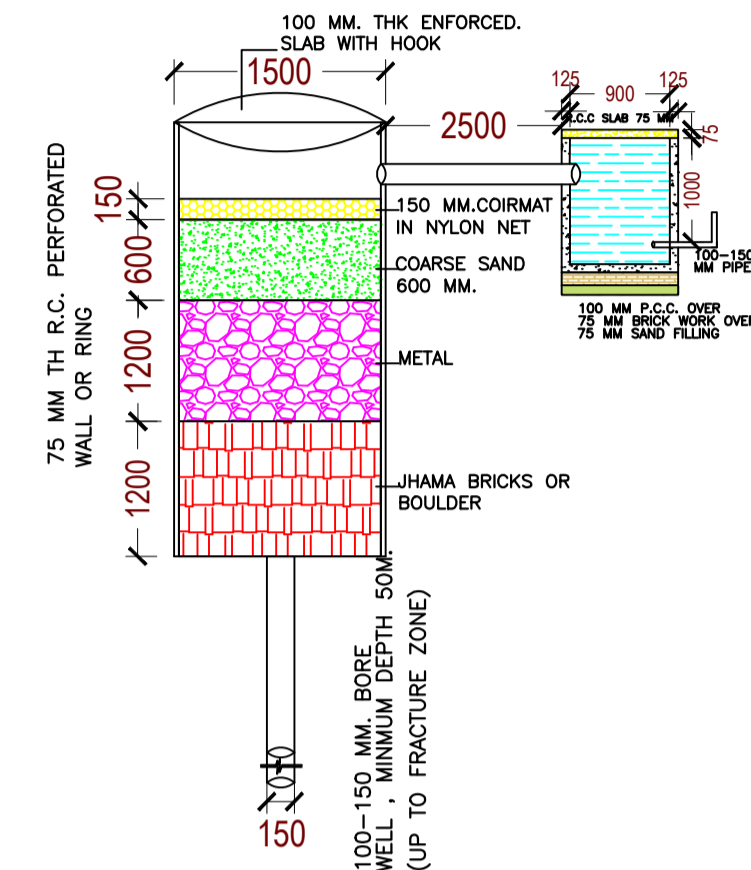

SECTION AT A-A (SCALE 1:50)

FAR & Tenement Details (Table 4c-1)

Building	No. of Same Bldg	Total Built Up Area (Sq.mt.)	Proposed FAR Area (Sq.mt.) Resi.	Total FAR Area (Sq.mt.)	Total Consumed Additional FAR Area (Sq.mt.)	Tnmt (No.)
A (SRI SUDARSAN PRASAD)	1	311.68	311.68	311.68	311.68	01
Grand Total :	1	311.68	311.68	311.68	311.68	01

SCHEDULE OF DOOR:

BUILDING NAME	NAME	LENGTH	HEIGHT	NOS
A (SRI SUDARSAN PRASAD)	D1	0.75	2.13	06
A (SRI SUDARSAN PRASAD)	D	0.95	2.13	12
A (SRI SUDARSAN PRASAD)	RS	1.07	2.13	02
A (SRI SUDARSAN PRASAD)	D0	1.07	2.13	01

SCHEDULE OF WINDOW/VENTILATION:

BUILDING NAME	NAME	LENGTH	HEIGHT	NOS
A (SRI SUDARSAN PRASAD)	V1	0.60	2.70	01
A (SRI SUDARSAN PRASAD)	V	0.60	2.70	01
A (SRI SUDARSAN PRASAD)	W2	1.00	2.70	02
A (SRI SUDARSAN PRASAD)	W	1.80	2.70	08
A (SRI SUDARSAN PRASAD)	W1	2.00	2.70	11

Building USE/SUBUSE Details

Building Name	Building Use	Building SubUse	Building Structure
A (SRI SUDARSAN PRASAD)	Residential	Bungalow/ Dwelling / Non Apartment	Non-Highrise

Buildingwise Floor FAR Details

Floor Name	Building Name A (SRI SUDARSAN PRASAD)		Total	
	Proposed Built Up Area (Sq.mt.)	Proposed FAR Area (Sq.mt.)	Total Proposed Built Up Area (Sq.mt.)	Total FAR Area (Sq.mt.)
Ground Floor	155.84	155.84	155.84	155.84
First Floor	155.84	155.84	155.84	155.84
Terrace Floor	0.00	0.00	0.00	0.00
Total :	311.68	311.68	311.68	311.68

UnitBUA Table for Building :A (SRI SUDARSAN PRASAD)

FLOOR	Name	UnitBUA Type	UnitBUA Area	Carpet Area	No. of Rooms	No. of Tenement
GROUND FLOOR PLAN	SPLIT A	FLAT	276.65	275.84	9	1
FIRST FLOOR PLAN	SPLIT A	FLAT	0.00	0.00	10	0
Total :	-	-	276.65	275.84	19	1

Building :A (SRI SUDARSAN PRASAD)

Floor Name	Total Built Up Area (Sq.mt.)	Proposed FAR Area (Sq.mt.) Resi.	Total FAR Area (Sq.mt.)	Total Consumed Additional FAR Area (Sq.mt.)	Tnmt (No.)
Ground Floor	155.84	155.84	155.84	155.84	01
First Floor	155.84	155.84	155.84	155.84	00
Terrace Floor	0.00	0.00	0.00	0.00	00
Total :	311.68	311.68	311.68	311.68	01
Total Number of Same Buildings :	1				
Total :	311.68	311.68	311.68	311.68	01

COLOR INDEX	
PLOT BOUNDARY	Black
ABUTTING ROAD	Green
PROPOSED CONSTRUCTION	Red
COMMON PLOT	Yellow
ROAD WIDENING AREA	Blue
EXISTING (To be retained)	Light Blue
EXISTING (To be demolished)	Orange

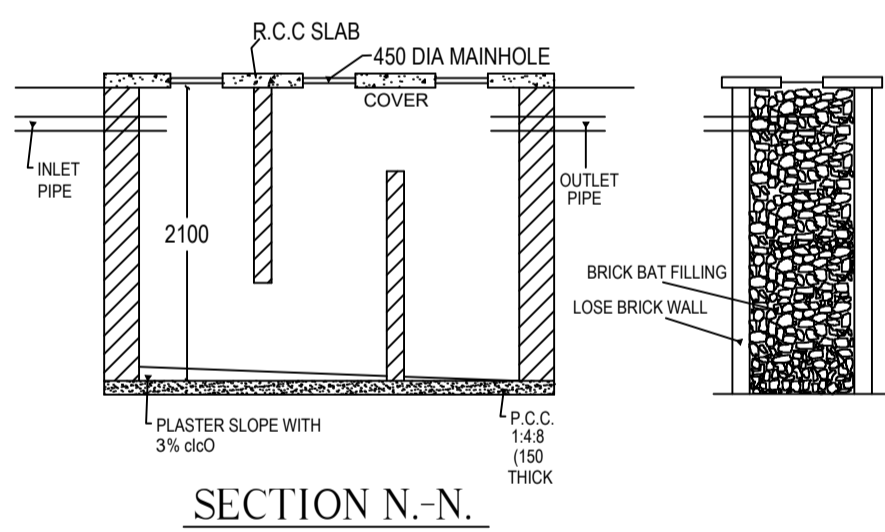

SECTION N.-N.

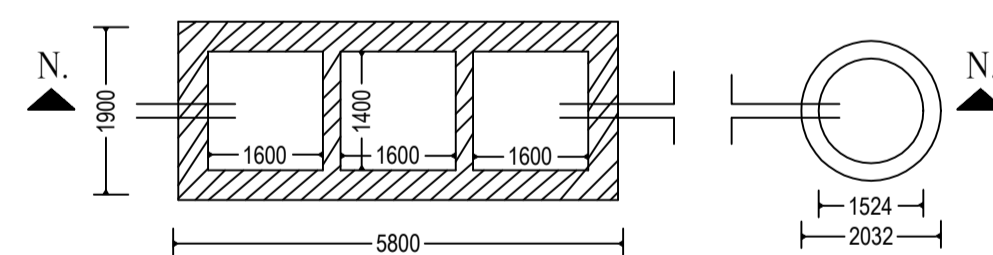

DETAIL OF SEPTIC TANK & SOAKPIT.

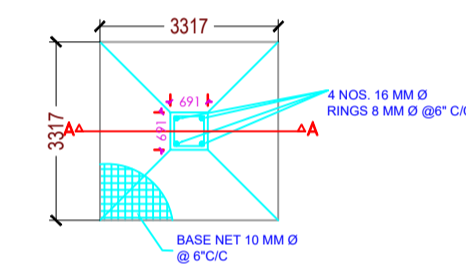

PLAN OF COLUMN FOUNDATION (SCALE= 1:50)

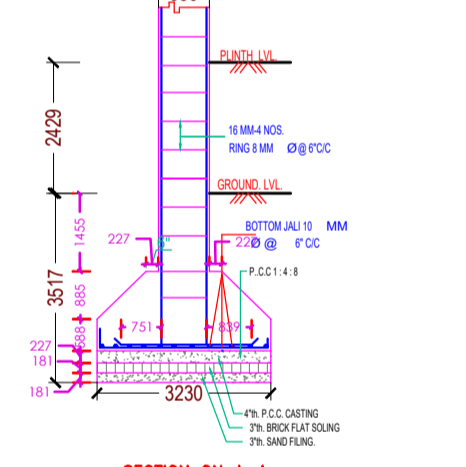

SECTION ON A-A (SCALE= 1:50)

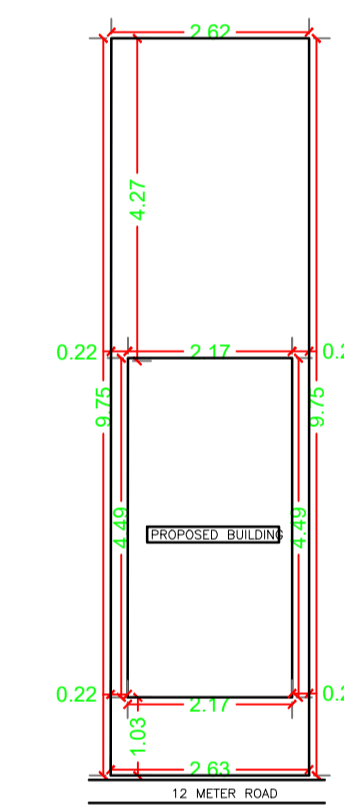

SITE PLAN (SCALE - 1:100)

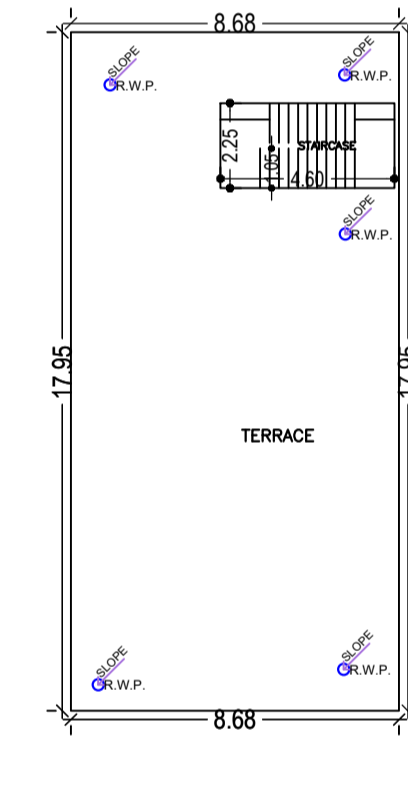

TERRACE FLOOR PLAN (SCALE 1:100)

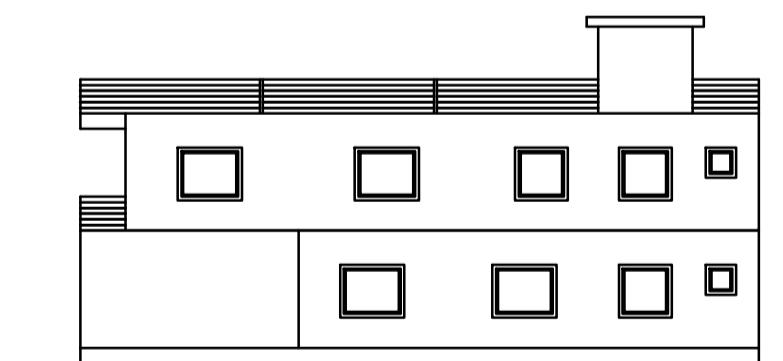

RIGHT SIDE ELEVATION (SCALE - 1:100)

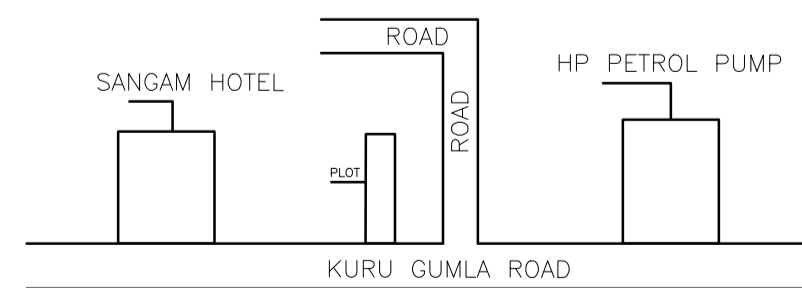

LOCATION SCALE - NTS

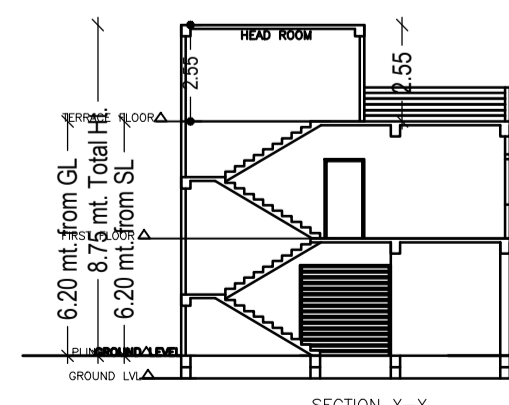

SECTION X-Y (SCALE - 1:100)

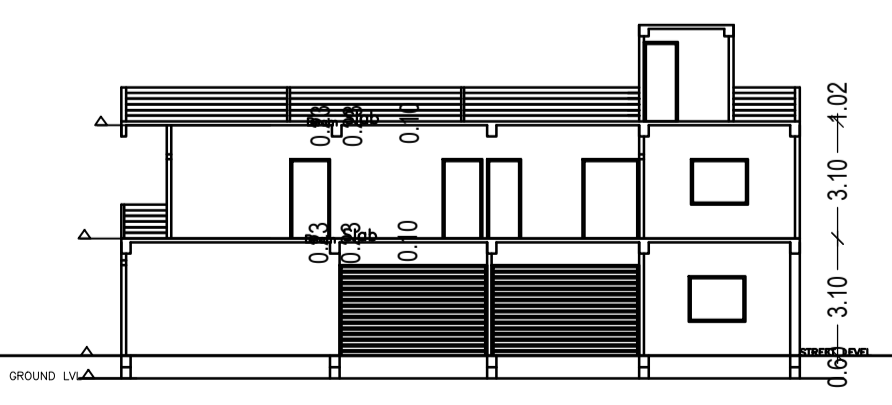

SECTION Y-Y (SCALE - 1:100)

LTP NAME AND SIGNATURE	STRUCTURAL ENG'S NAME AND SIGNATURE	BUILDER NAME AND SIGNATURE	DIGITAL SIGNATURE
ASHWINI KUMAR SAHU LNP/ENG/0005/2017			