

Project Title :RESIDENTIAL BUILDING G+1

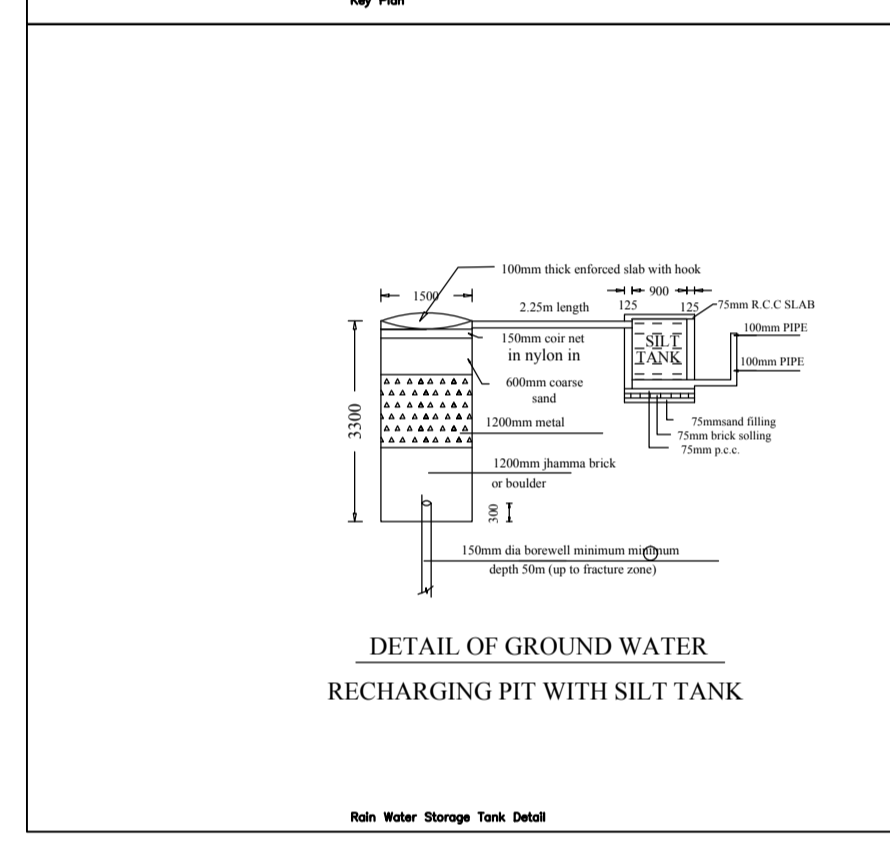
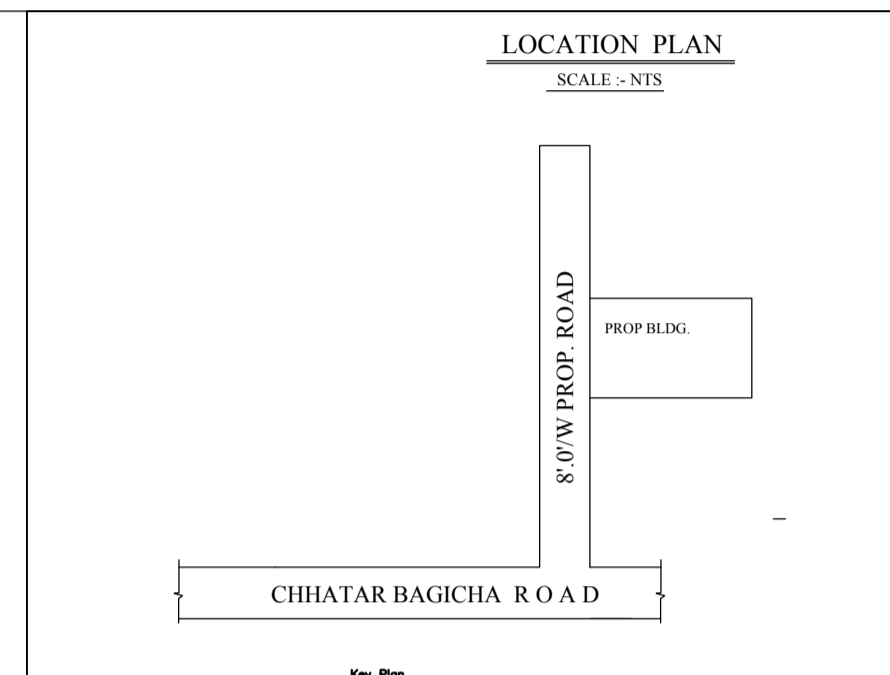
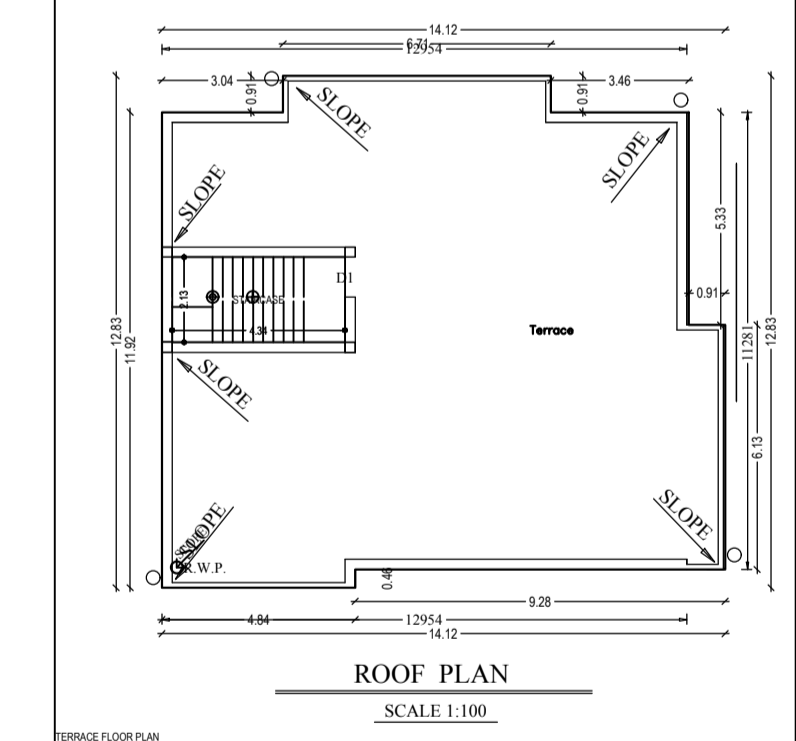
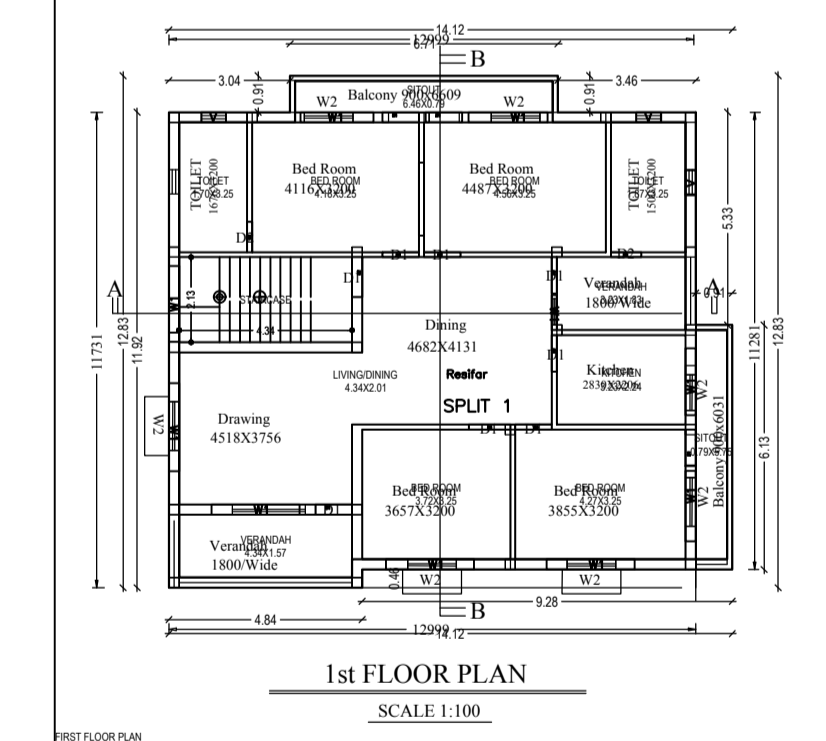
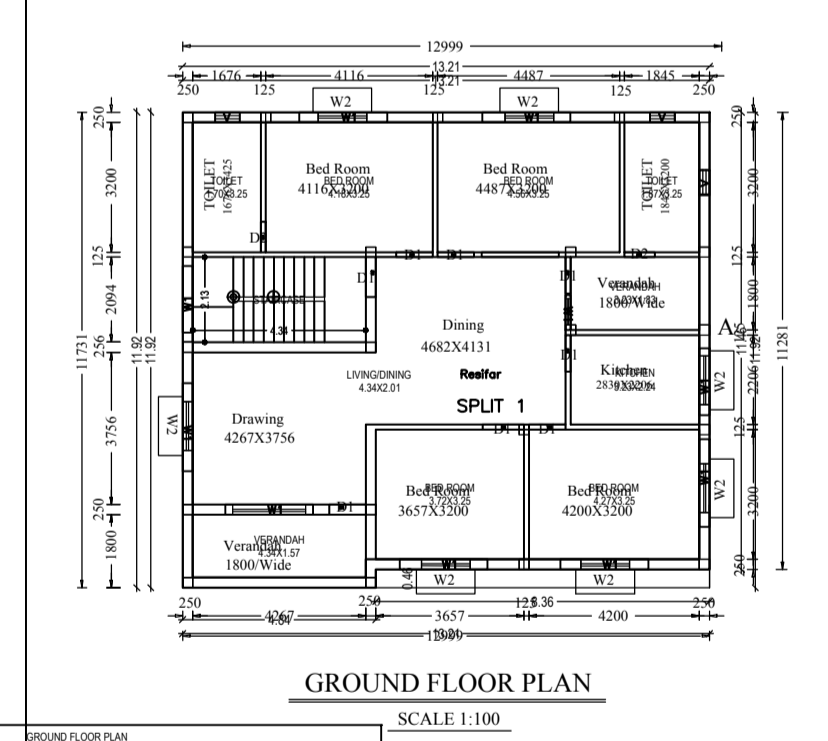
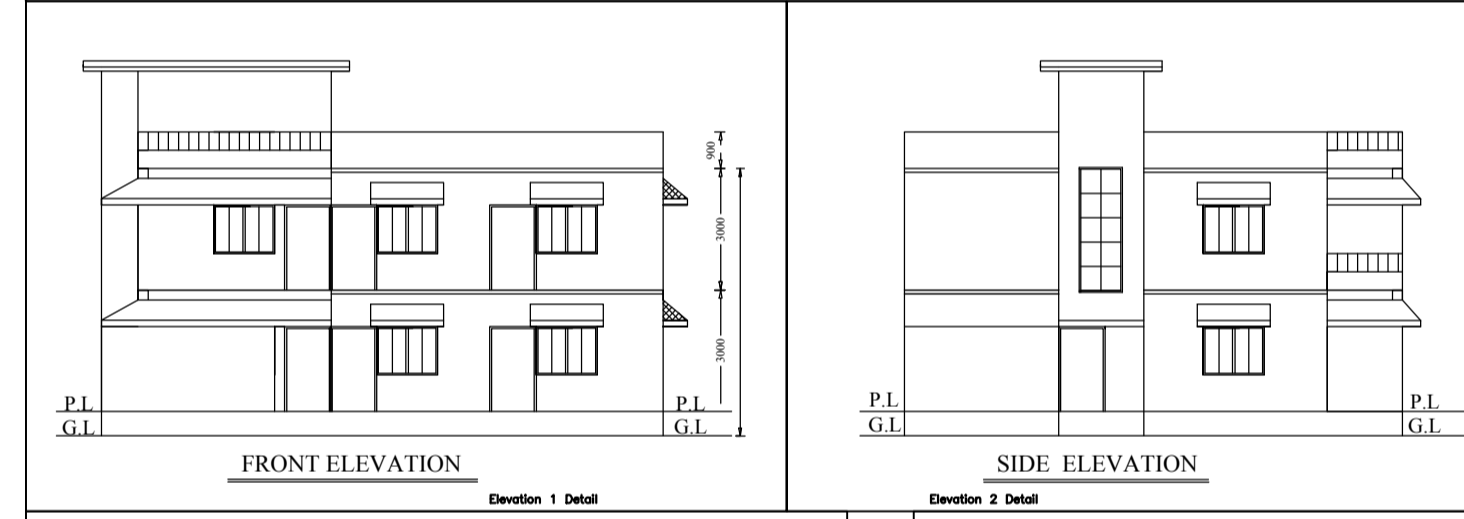
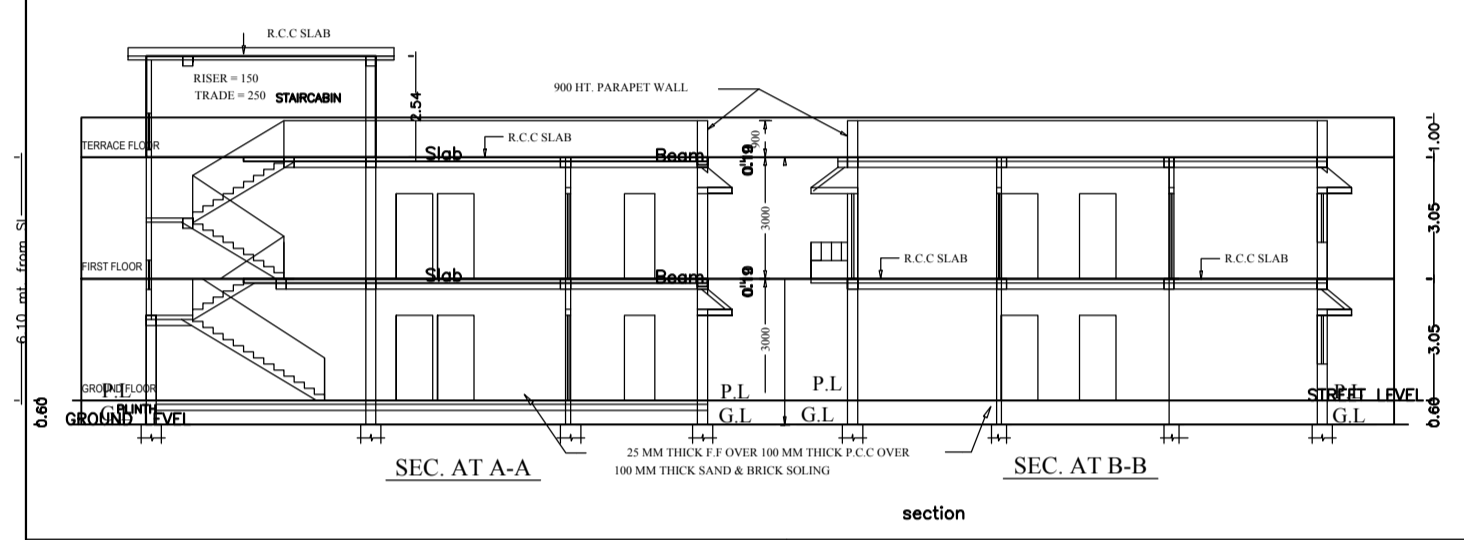
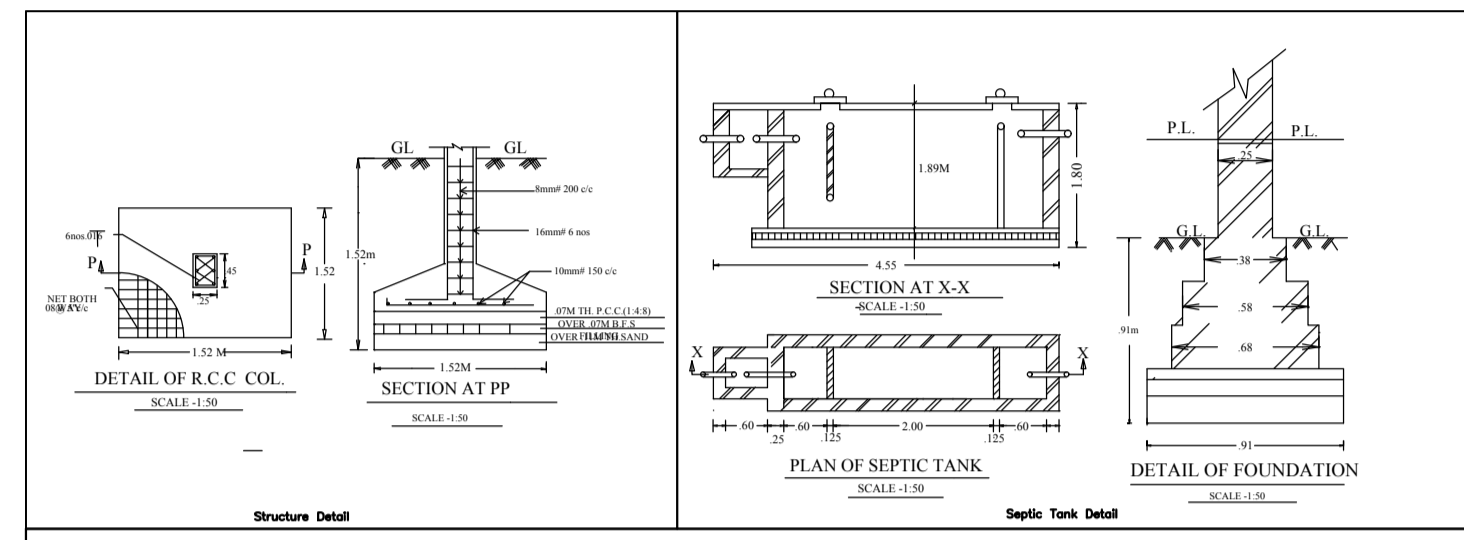

SPACE FOR STAMP

SPECIFICATIONS

1. WALL FOUNDATION - P.C.C.(1:3:6).
2. COLUMN FOOTING - R.C.C. (1:2:4).
3. LINTELS, BEAMS & ROOF SLAB R.C.C.(1:2:4).
4. WALL FOOTING & SUPER STRUCTURE 1ST CLASS B/W IN CM.(1:6).
5. D.P.C.--P.C.C.(1:1.5:3)+2% C.I.C.O.
6. FLOOR FINISH IN SITU MOSAIC OR MOSAIC TILES.
7. DOORS & WINDOWS STEEL CHOWKHAT & STEEL FRAME SHUTTER.
8. WALL FINISH 0.012M TH. CEMENT PLASTER ON BOTH SIDE PAINTED INSIDE DRY DISTEMPER & SNOWCEM

SCHEDULE OF DOORS & WINDOWS

TYPE	WIDTH	HT.	SILL	DESCRIPTION
D1	900	2100	0.00	STEEL FRAME
D2	750	2100	0.00	PANEL SHUTTER
D3	1050	2100	0.00	STEEL FRAME
W1	1500	1200	900	GLAZED SHUTTER
W2	1200	1200	900	
W3	900	1200	900	
V	600	600	1500	

AREA CALCULATION

2. PLOT AREA AS PER SITE = 414.77 SQM

GROUND FLOOR AREA = 148.78 SQM

1st FLOOR AREA = 148.78 SQM

TOTAL COVERED AREA = 297.56 SQM

F.A.R = 0.717

% GROUND COVERAGE = 35.87

PROPOSED RESIDENTIAL BUILDING OF

SMT NARMADA BURMAN W/O SRI ASHOK KUMAR BURMAN

CHHATAR BAGICHA THANA & DIST-LOHARDAGA, THANA NO. 194,

R.S PLOT NO. 1392, M/S PLOT NO.2427, WARD NO -21 .

SIGNATURE OF APPLICANTS

REGD. LICENCE NO.--

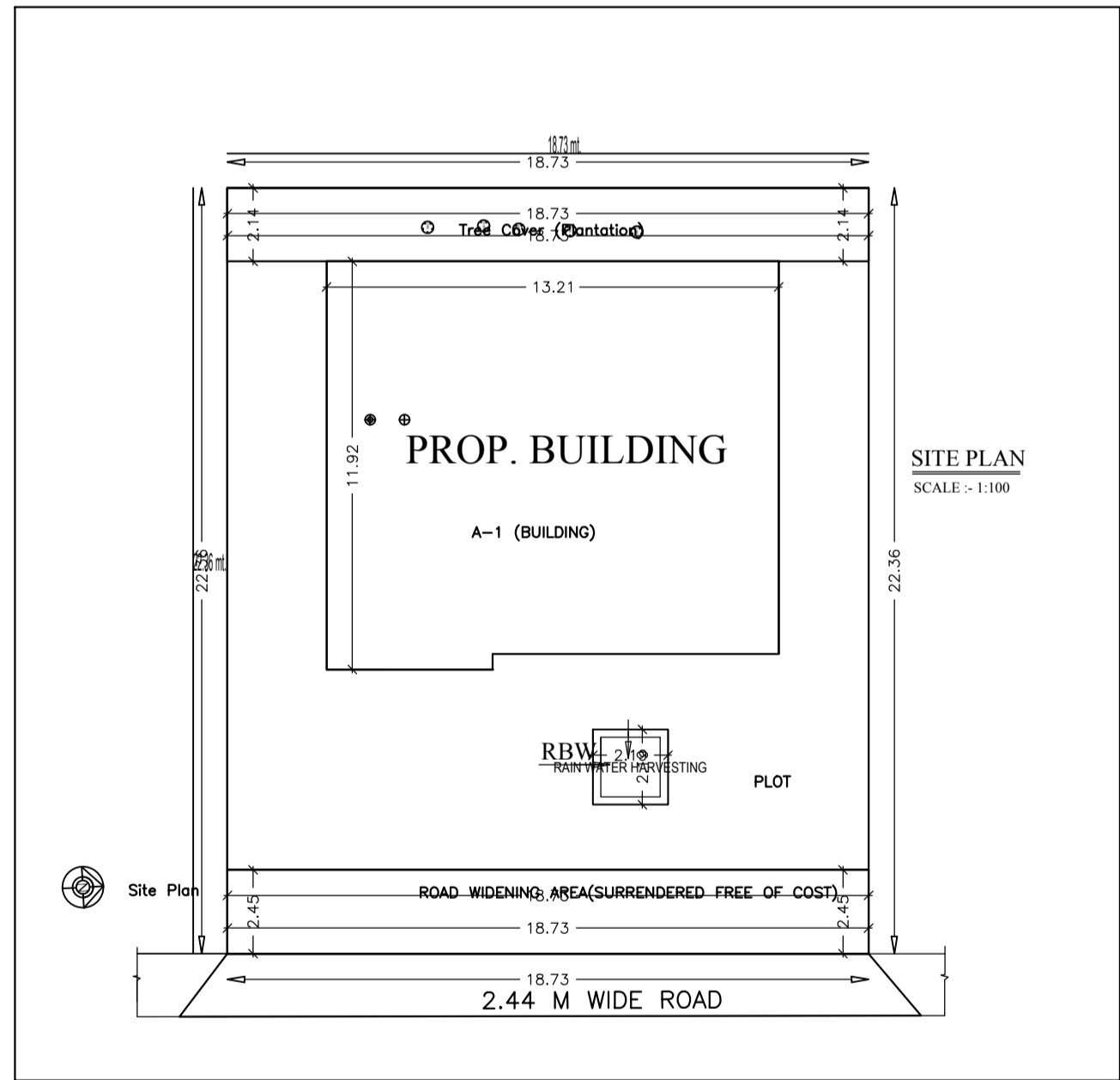

AREA STATEMENT :LOHARDAGA WARD PARIBAS

VERSION NO. :13.31

VERSION DATE: 30/10/2023

PROJECT DETAIL	ITEM NO.	DESCRIPTION
Plot No.	194	Residential
Block No.	194	Residential
Survey No.	194	Residential
Project Name	Residential Building	Residential
Location	Chhatar Bagicha	Residential

AREA/DETAIL	AREA (Sq. M)	% OF TOTAL
Plot Area	414.77	100%
Ground Floor Area	148.78	35.87%
1st Floor Area	148.78	35.87%
Total Covered Area	297.56	71.74%

COLOR INDEX

ITEM	COLOR
Plot Boundary	Red
Abutting Road	Blue
Proposed Floor Coverage Area	Green
Existing Floor Coverage Area	Yellow

FAR & Tariff Details (Table 4c-1)

Building	No. of Storey	Proposed FAR	Proposed FAR Area	Tariff
A (BUILDING)	2	0.717	297.56	01

Schedule of Joinery

ITEM NAME	QTY	UNIT	REMARKS
Column	4	NO.	
Beam	12	NO.	
Slab	2	NO.	

Schedule of Formwork

ITEM NAME	QTY	UNIT	REMARKS
Formwork for Column	32	Sq. M	
Formwork for Beam	24	Sq. M	
Formwork for Slab	4	Sq. M	

UNSLA Table for Building A (BUILDING)

ITEM	Name	UNSLA No	UNSLA Area	UNSLA Rate	No. of Items	Total Amount
FORMWORK	SPLIT 1	FLAT	294.87	294.87	10	2948.70
FORMWORK	SPLIT 1	FLAT	294.87	294.87	22	65072.40

A (BUILDING)