

Proposal Basic Information	
Proposal File No.	LNP/BP/0057/W22/2021
Owner Name	AMRIT KUMARI
Khata No	63
Plot No	796
Village Name	Lohardaga
Use	Residential
SubUse	Bungalow/ Dwelling / Non Apartment

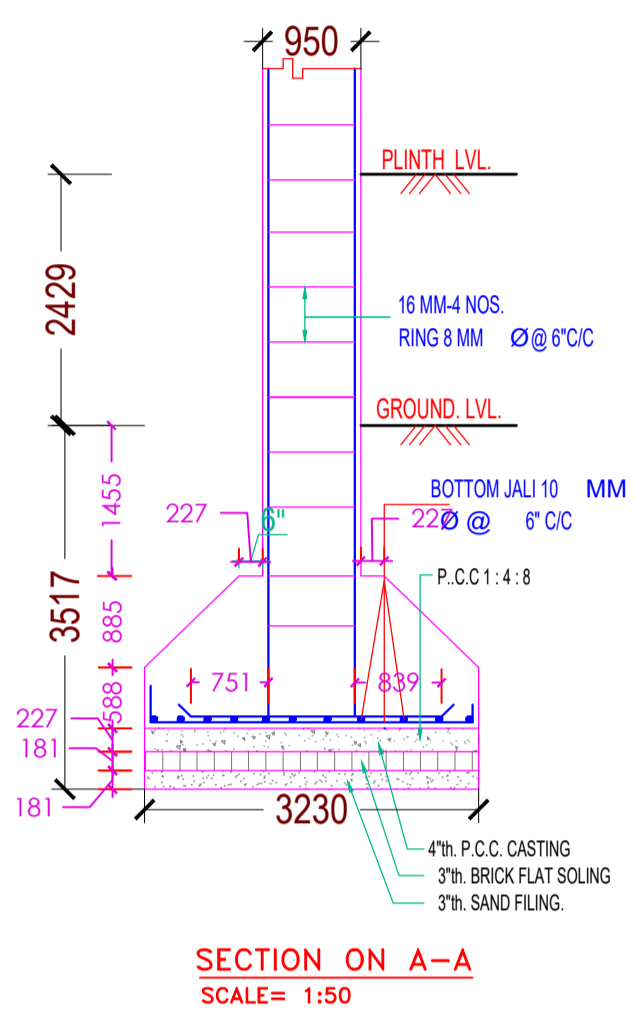
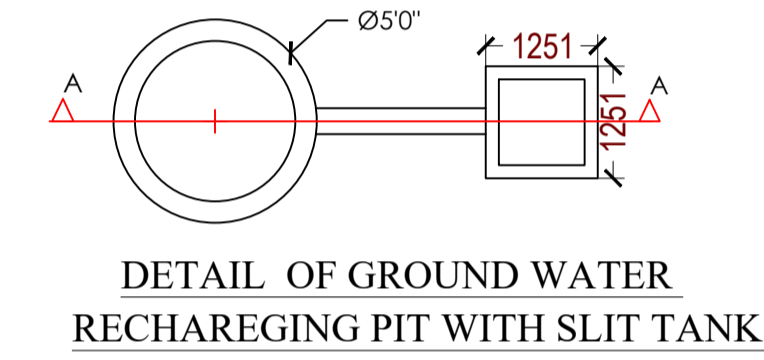
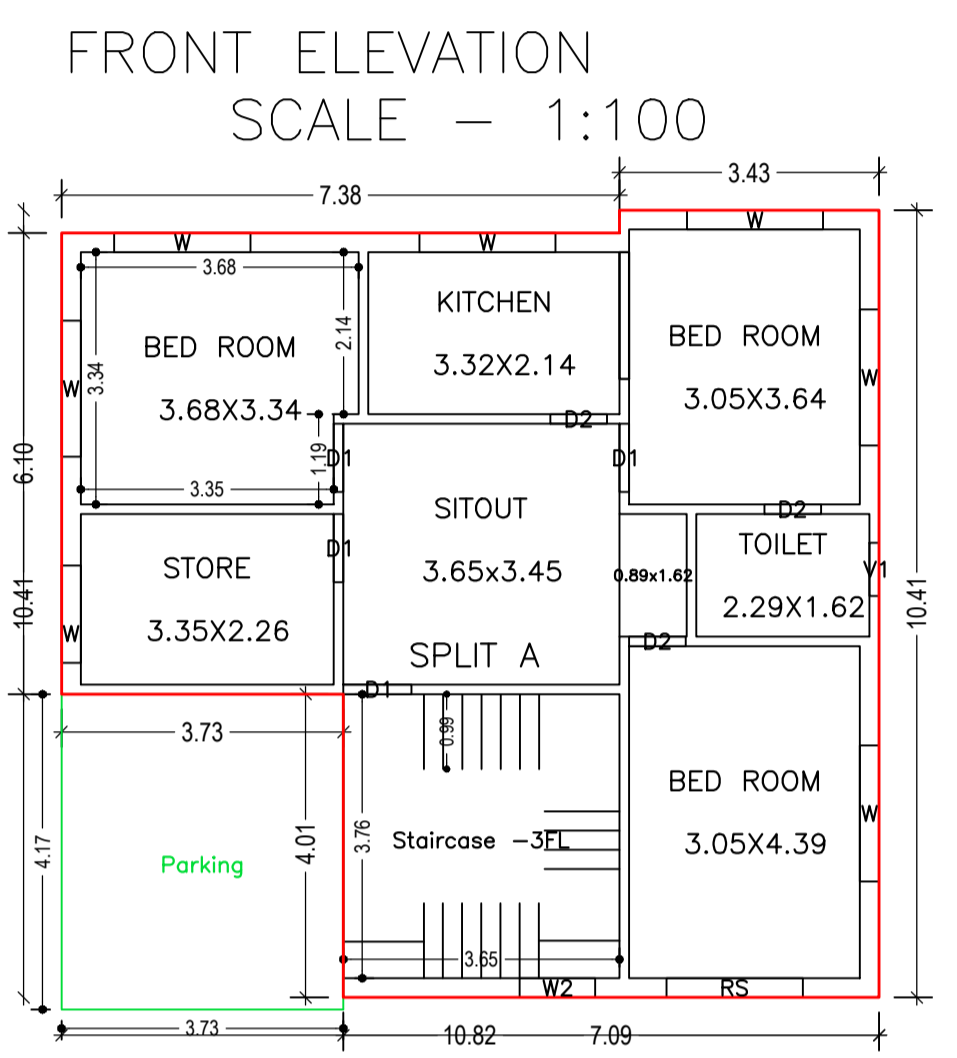
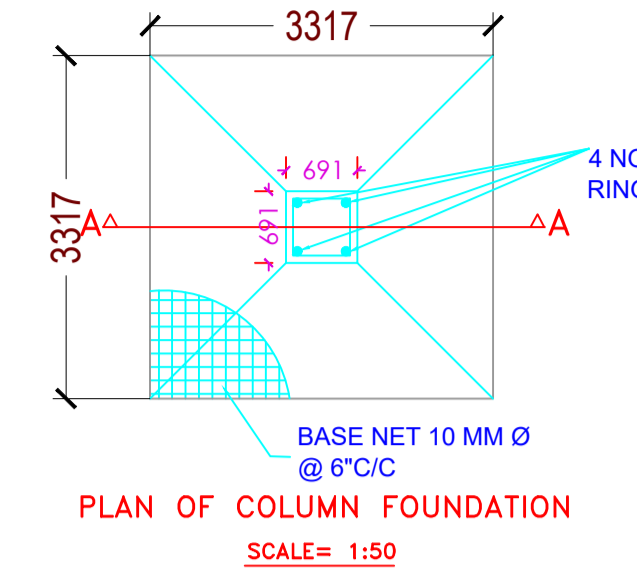
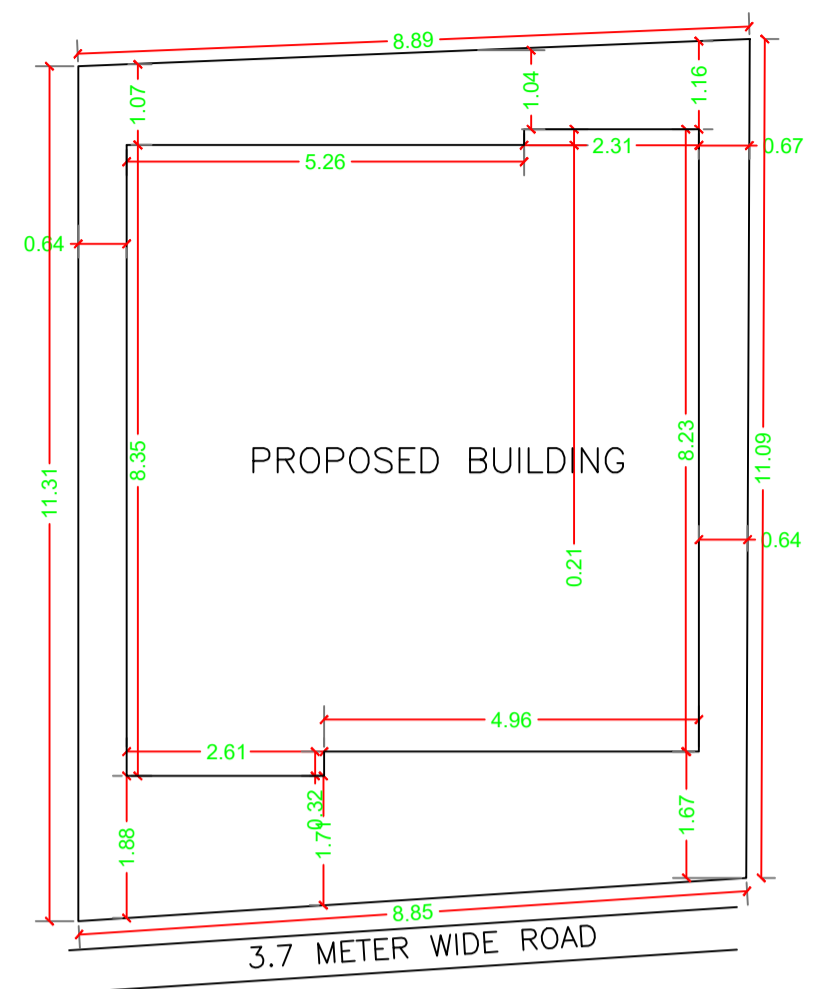
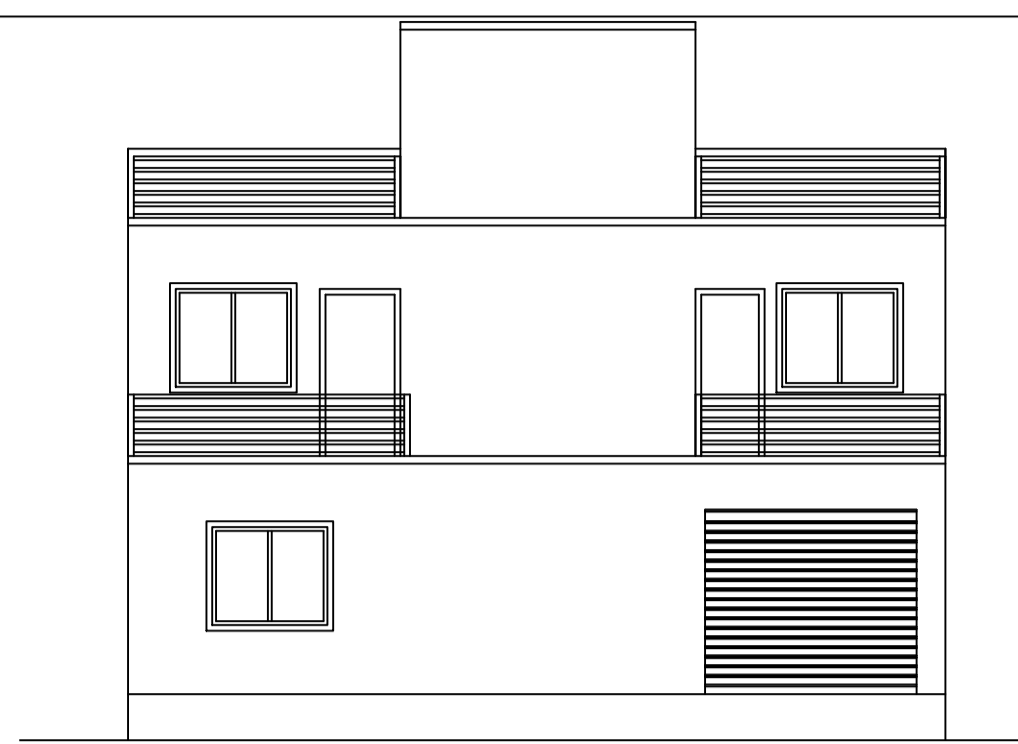
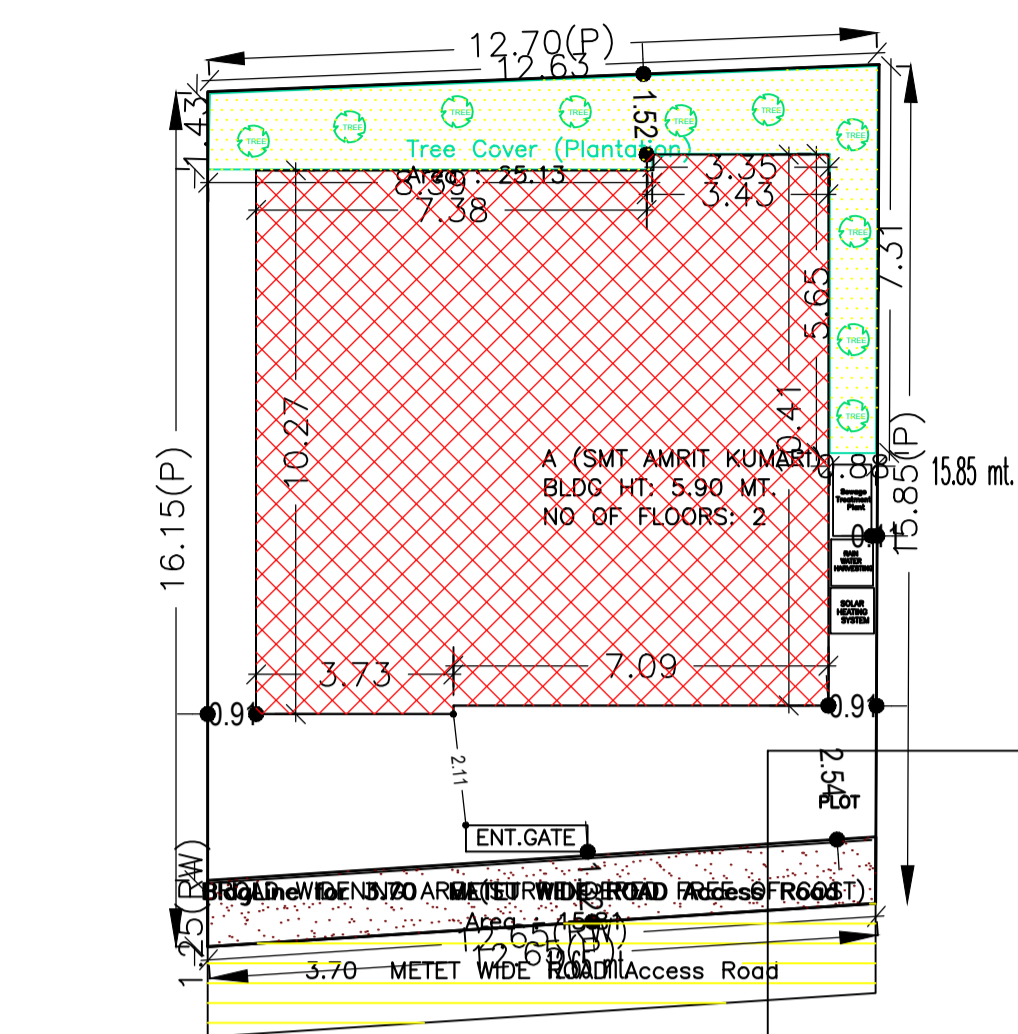
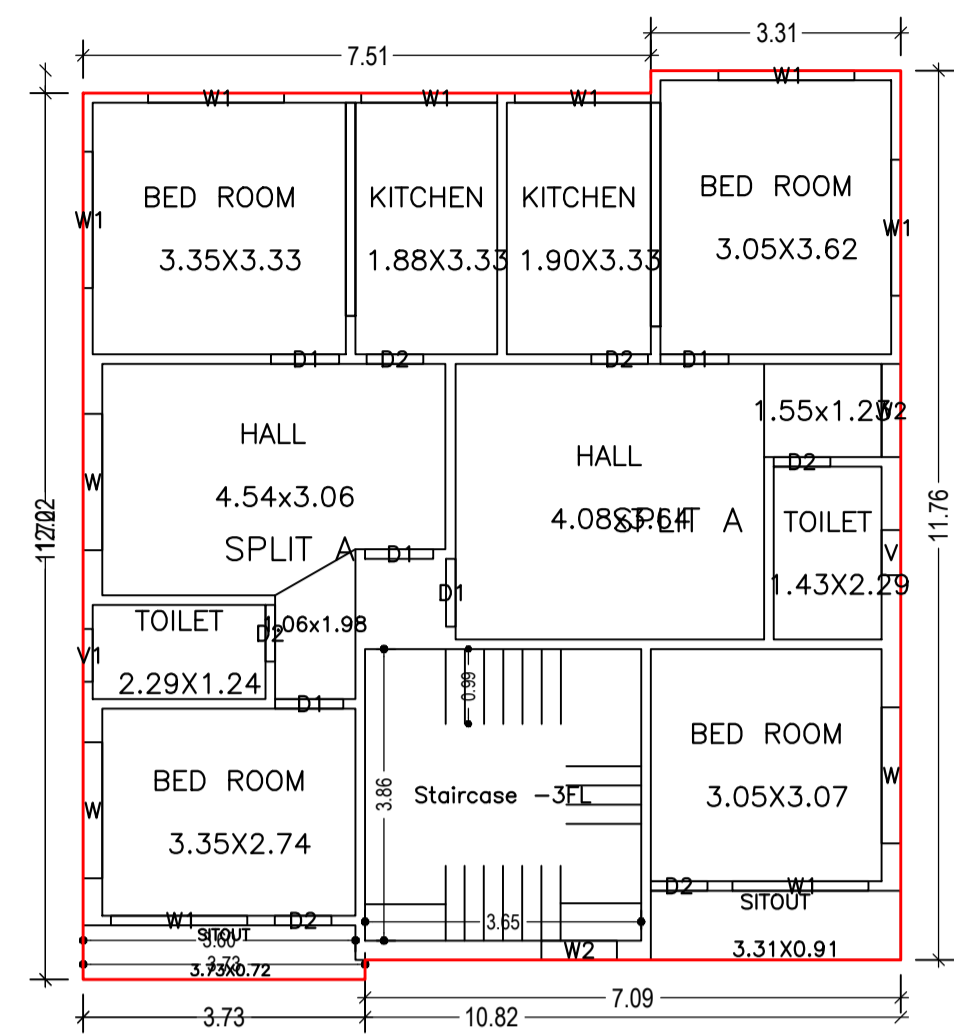

UnitBUA Table for Building :A (SMT AMRIT KUMARI)

FLOOR	Name	UnitBUA Type	UnitBUA Area	Carpet Area	No. of Rooms	No. of Tenement
GROUND FLOOR PLAN	SPLIT A	FLAT	173.03	172.08	7	1
FIRST FLOOR PLAN	SPLIT A	FLAT	0.00	0.00	6	0
Total:	-	-	173.03	172.08	19	1

SCHEDULE OF DOOR:

BUILDING NAME	NAME	LENGTH	HEIGHT	NOS
A (SMT AMRIT KUMARI)	D2	0.75	2.13	09
A (SMT AMRIT KUMARI)	D1	0.90	2.13	09
A (SMT AMRIT KUMARI)	RS	1.80	2.13	01

SCHEDULE OF WINDOW/VENTILATION:

BUILDING NAME	NAME	LENGTH	HEIGHT	NOS
A (SMT AMRIT KUMARI)	V	0.60	2.70	01
A (SMT AMRIT KUMARI)	V1	0.70	2.70	02
A (SMT AMRIT KUMARI)	W2	1.00	2.70	02
A (SMT AMRIT KUMARI)	W2	1.23	2.70	01
A (SMT AMRIT KUMARI)	W	1.29	2.70	01
A (SMT AMRIT KUMARI)	W1	1.80	2.70	08
A (SMT AMRIT KUMARI)	W	1.80	2.70	09

Building USE/SUBUSE Details

Building Name	Building Use	Building SubUse	Building Structure
A (SMT AMRIT KUMARI)	Residential	Bungalow/ Dwelling / Non Apartment	Non-Highrise

Buildingwise Floor FAR Details

Floor Name	Building Name A (SMT AMRIT KUMARI)		Total	
	Proposed Built Up Area (Sq.mt.)	Proposed FAR Area (Sq.mt.)	Total Proposed Built Up Area (Sq.mt.)	Total FAR Area (Sq.mt.)
Ground Floor	110.98	95.43	110.98	95.43
First Floor	125.92	125.92	125.92	125.92
Terrace Floor	0.00	0.00	0.00	0.00
Total :	236.90	221.35	236.90	221.35

Building :A (SMT AMRIT KUMARI)

Floor Name	Total Built Up Area (Sq.mt.)	Deductions (Area in Sq.mt.)		Proposed FAR Area (Sq.mt.)	Total FAR Area (Sq.mt.)	Total Consumed Additional FAR Area (Sq.mt.)	Tnmt (No.)
		Parking	Resi.				
Ground Floor	110.98	15.55	95.43	95.43	95.43	01	
First Floor	125.92	0.00	125.92	125.92	125.92	00	
Terrace Floor	0.00	0.00	0.00	0.00	0.00	00	
Total :	236.90	15.55	221.35	221.35	221.35	01	
Total Number of Same Buildings :	1						
Total :	236.90	15.55	221.35	221.35	221.35	01	

FAR & Tenement Details (Table 4c-1)

Building	No. of Same Bldg	Total Built Up Area (Sq.mt.)	Deductions (Area in Sq.mt.)		Proposed FAR Area (Sq.mt.)	Total FAR Area (Sq.mt.)	Total Consumed Additional FAR Area (Sq.mt.)	Tnmt (No.)
			Parking	Resi.				
A (SMT AMRIT KUMARI)	1	236.90	15.55	221.35	221.35	221.35	01	
Grand Total :	1	236.90	15.55	221.35	221.35	221.35	01	

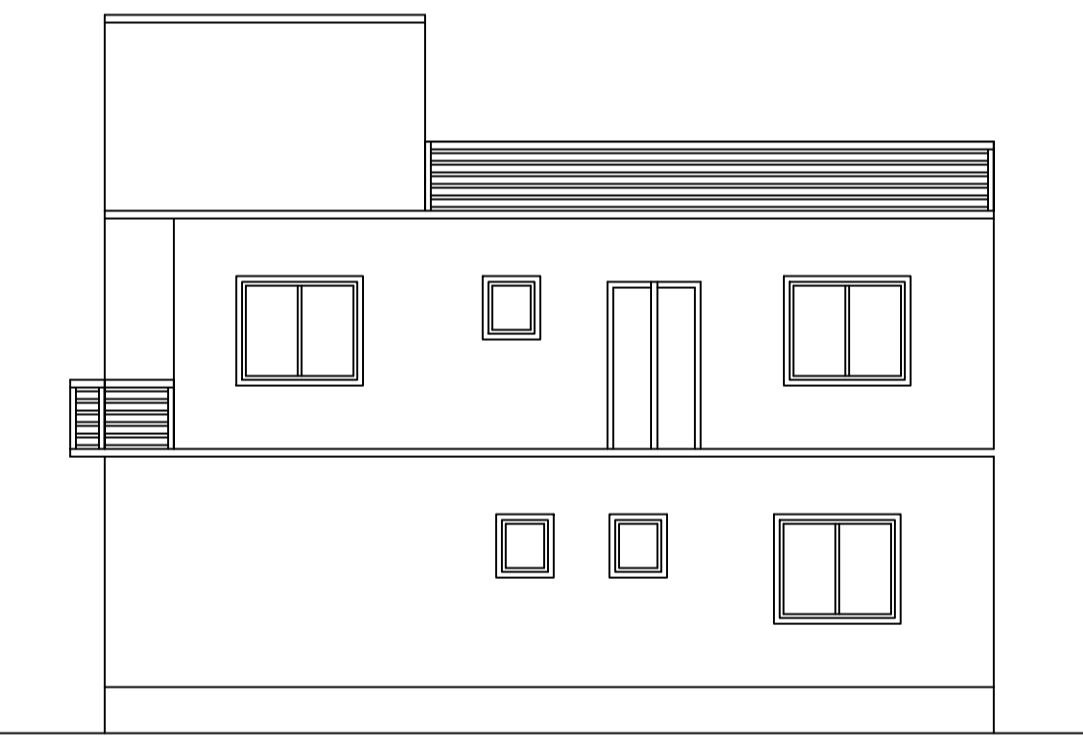
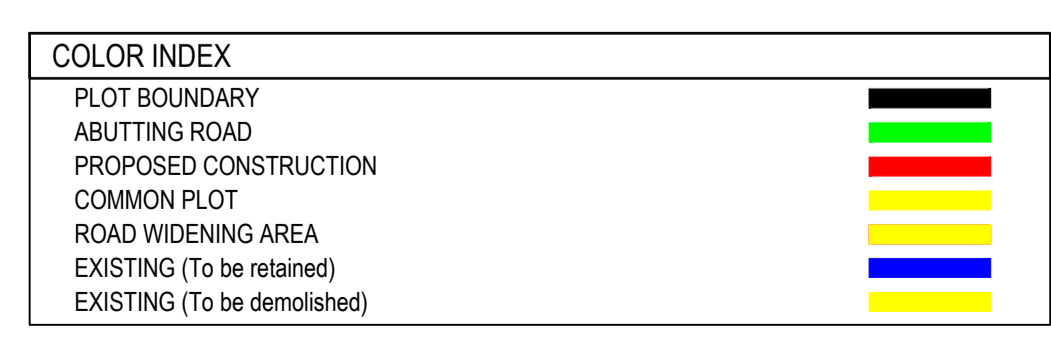

GROUND FLOOR PLAN (Proposed) (SCALE 1:100)

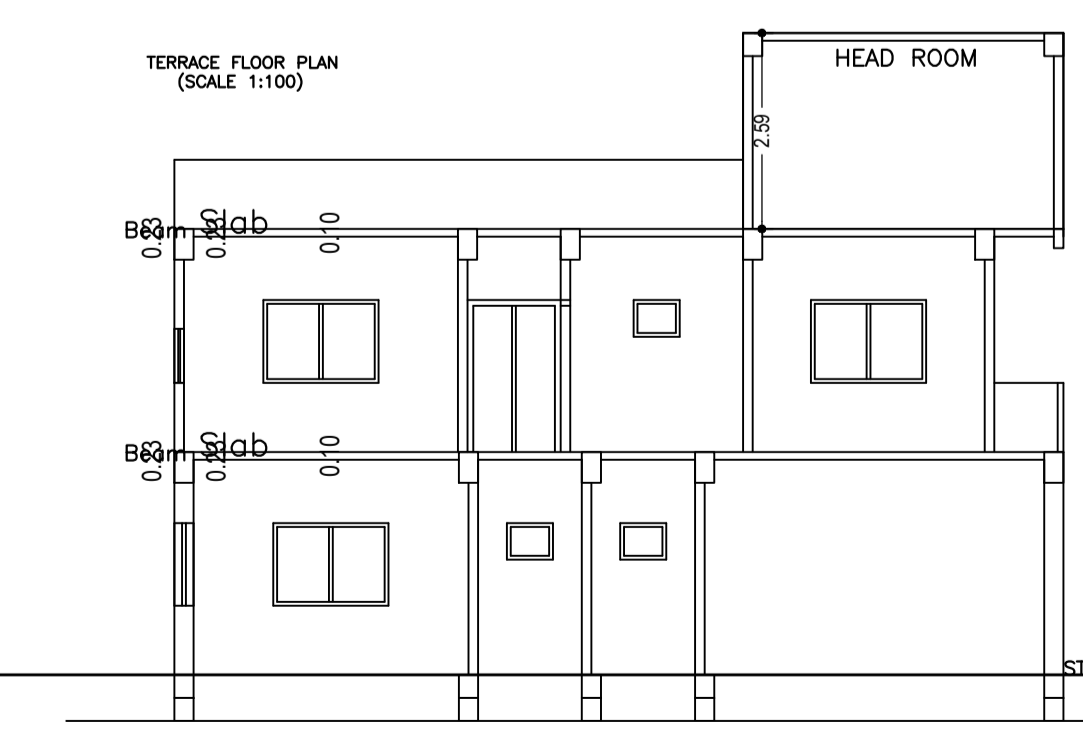
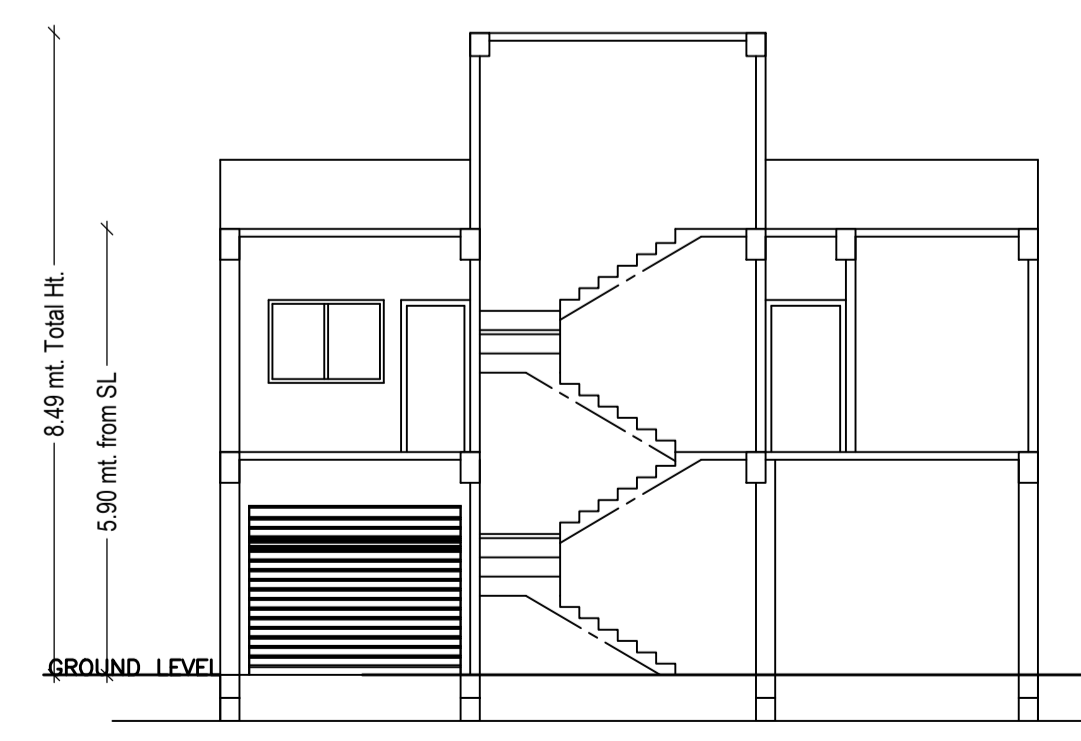
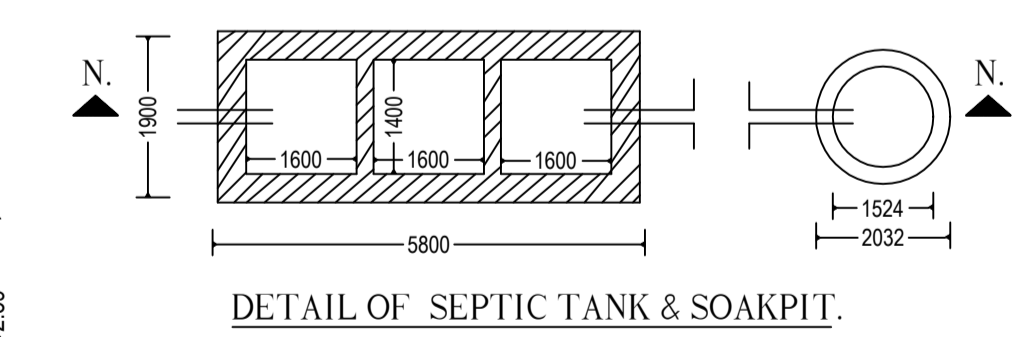
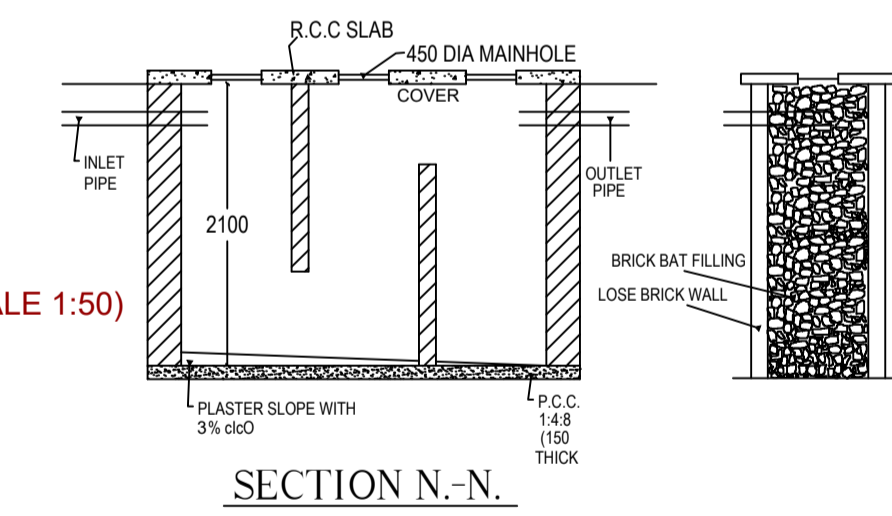
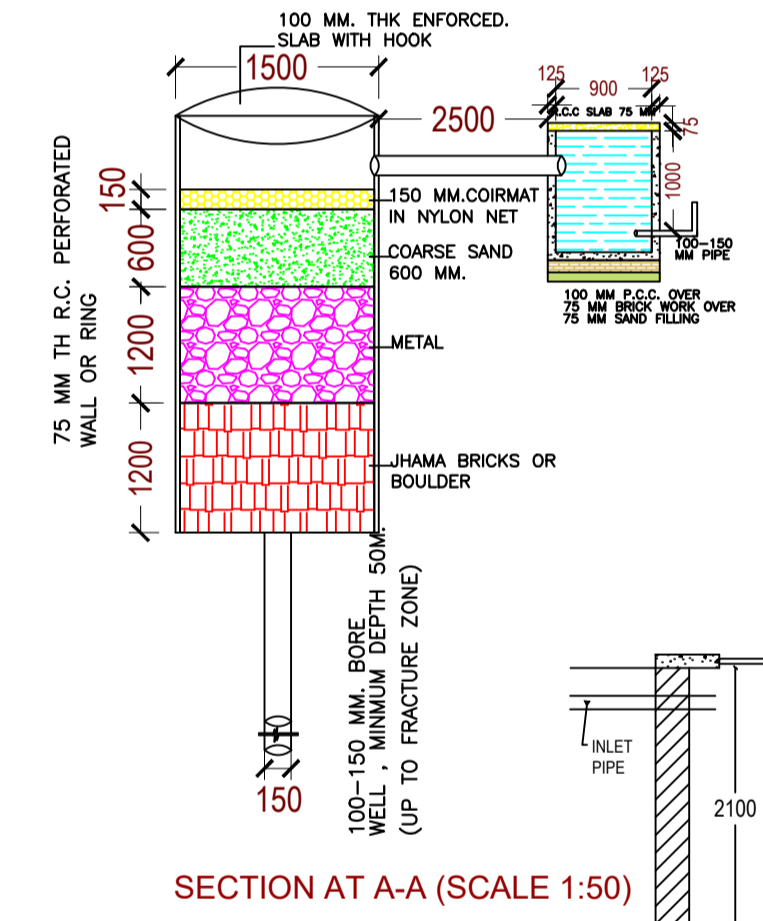
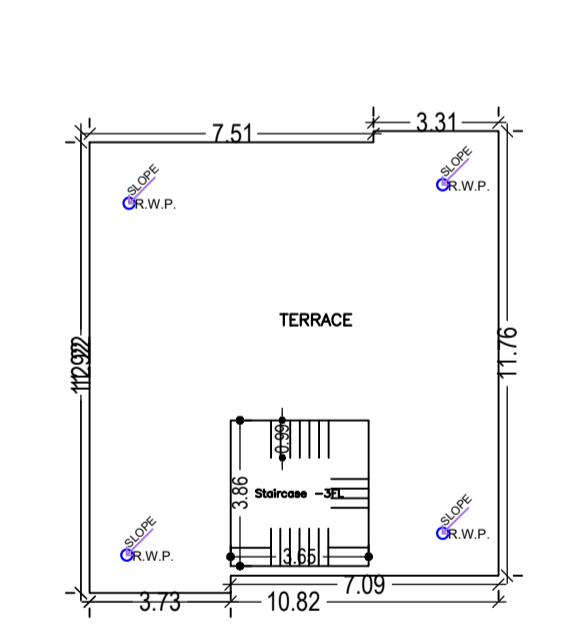

SECTION X-X' SCALE - 1:100

SECTION Y-Y' SCALE - 1:100

AREA STATEMENT	VERSION NO. : 1.0.61	SQ.MT.
LOHARDAGA NAGAR PARISHAD	VERSION DATE: 16/10/2020	202.50
PROJECT DETAIL:		
Region: JHARKHAND URBAN LOCAL BODIES	Plot Use: Residential	
District: LOHARDAGA	Plot SubUse: Bungalow/ Dwelling / Non Apartment	
Authority: LOHARDAGA NAGAR PARISHAD	PlotNearbyReligiousStructure: NA	
Inward No: LNP/BP/0057/W22/2021	Plot/SubPlot No: 796	
Application Type: General Proposal	North: Road Width - 3.70	
Project Type: Building Permission	South: Plot No. - 795	
Nature of Development: New	East: Plot No. - 796	
Location of Development Area: Old Area	West: Plot No. - 796	
AREA DETAILS:		
AREA OF PLOT (Minimum)	(A)	202.50
Deduction for NetPlot Area		
Surrender Free of Cost		15.81
Total		15.81
NET AREA OF PLOT(Gross Plot Area - Deduction from Gross Plot Area)	(A-Deductions)	186.69
Deduction for Balance Plot Area(from Gross Plot Area)		
Surrender Free of Cost		15.81
Common Plot		25.13
Total		40.95
BALANCE AREA OF PLOT(Net Plot Area - Recreational/Amenity space)	(A-Deductions)	161.55
PLOT AREA FOR COVERAGE(Net Plot Area)	(A-Deductions)	186.69
Plot Area for FAR (Net Plot Area + Road/Widening Area)	(A-Deductions)	202.50
COVERAGE CHECK		
Permissible Coverage area (70.00 %)		130.68
Proposed Coverage Area (59.45 %)		110.99
Total Prop. Coverage Area (59.45 %)		110.99
Balance coverage area (10.55 %)		19.69
FAR CHECK		
Perm. FAR Area (1.50)		303.75
Total Perm. FAR area		303.75
Residential FAR		221.36
Proposed FAR Area		221.36
Total Proposed FAR Area		221.36
Consumed FAR (Factor)		1.09
Balance FAR Area		82.39
BUILT UP AREA CHECK		
Total Proposed BuiltUp Area		236.90
ARCHITECT (Regd)		ASHWINI KUMAR SAHU
ENGINEER (Regd)		
SUPERVISOR (Regd)		AMRIT KUMARI
OWNER (Regd)		
DEVELOPMENT AUTHORITY		LOCAL BODY

LTP NAME AND SIGNATURE	STRUCTURAL ENG'S NAME AND SIGNATURE	BUILDER NAME AND SIGNATURE	DIGITAL SIGNATURE
ASHWINI KUMAR SAHU LNP/ENG/0005/2017			