

Project Title :

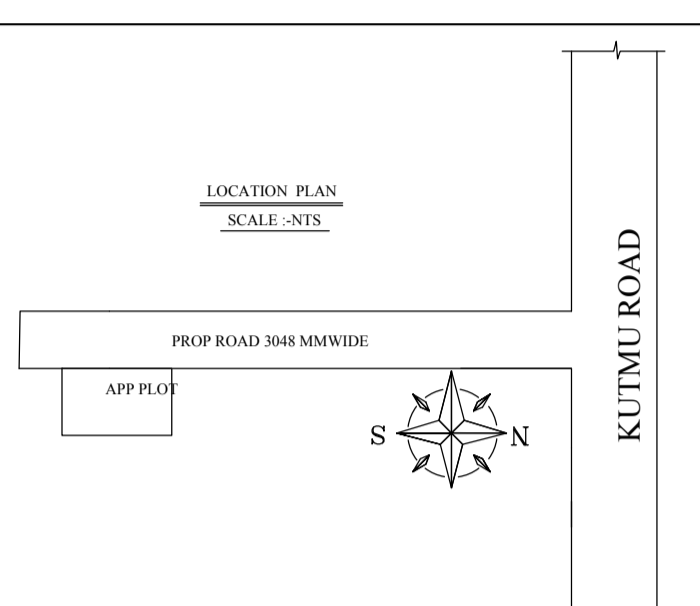

SPACE FOR STAMP

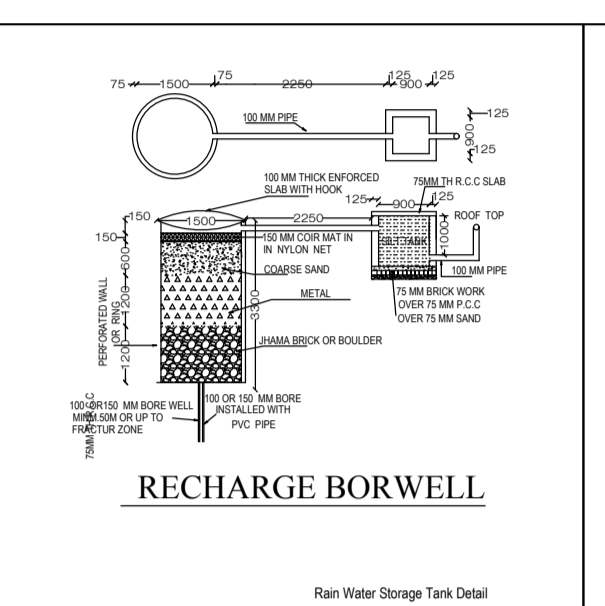
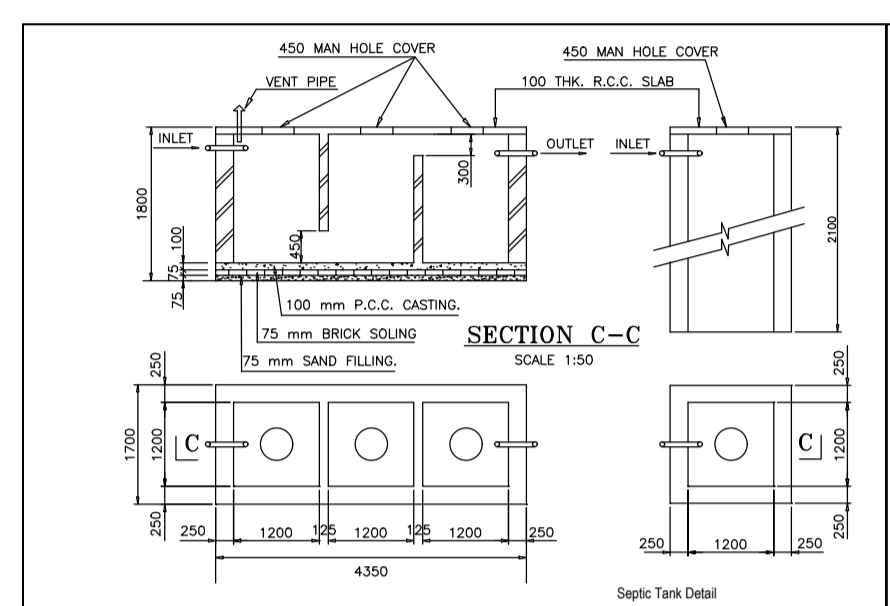
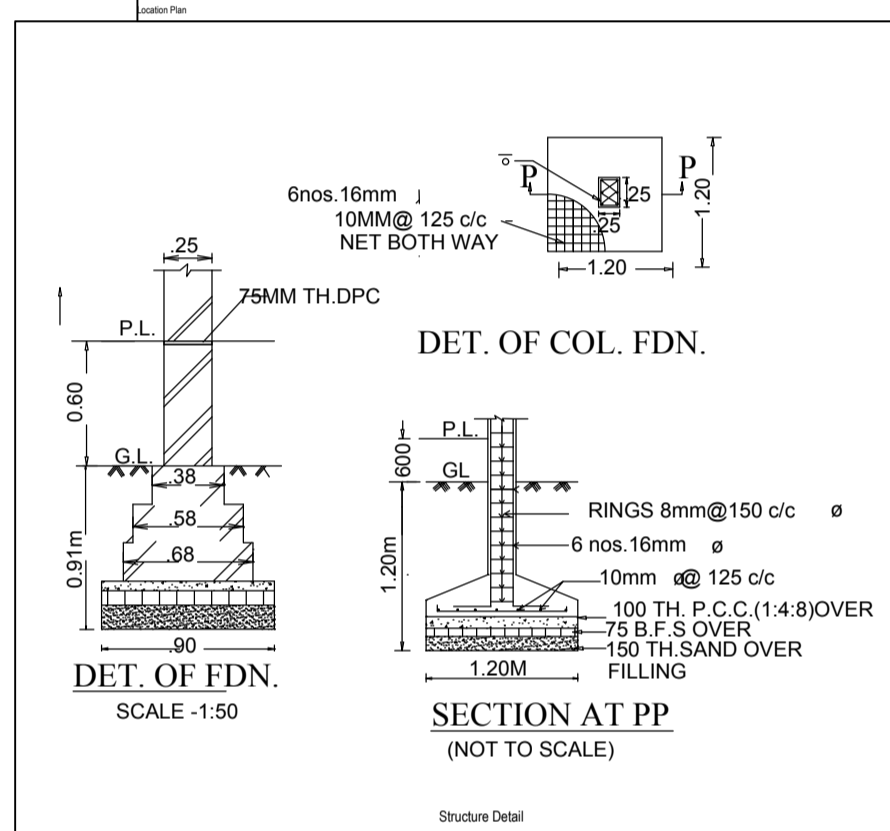
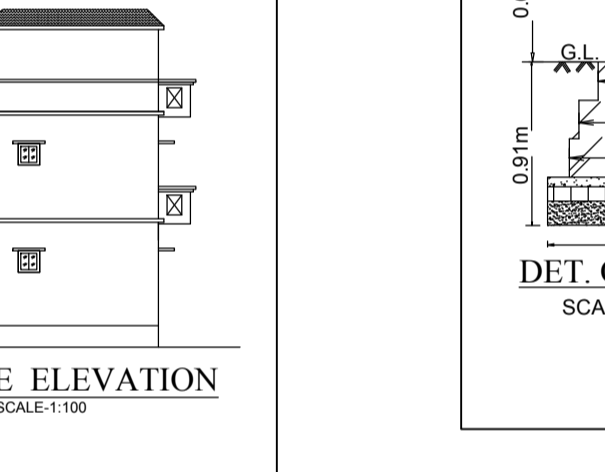
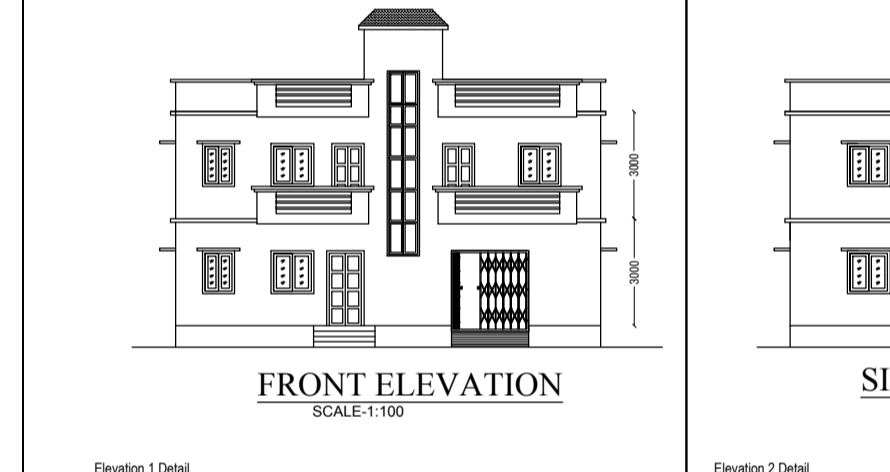
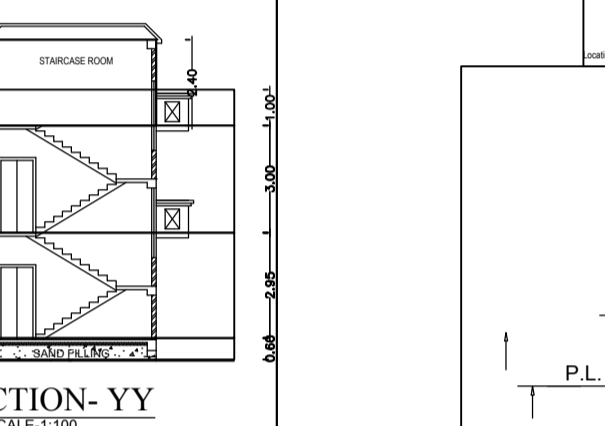
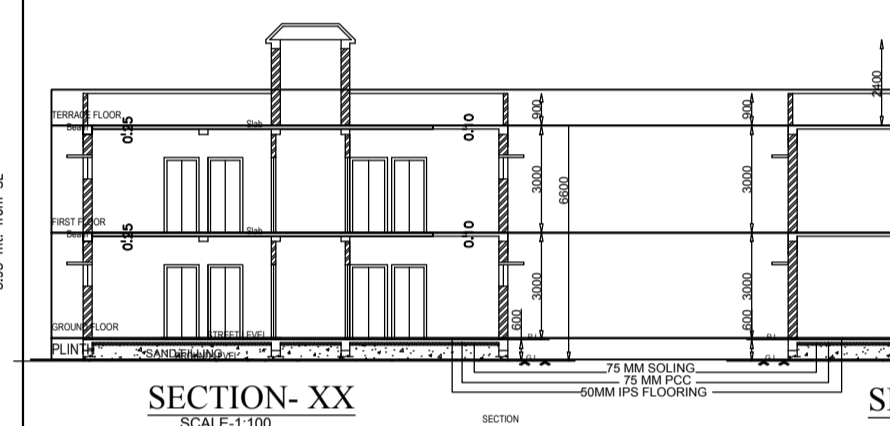

- SPECIFICATIONS
1. WALL FOUNDATION - P.C.C.(1:3:6)
 2. COLUMN FOOTING -- R.C.C. (1:1.5:3)
 3. LINTELS, BEAMS & ROOF SLAB R.C.C.(1:1.5:3)
 4. WALL FOOTING & SUPER STRUCTURE 1ST. CLASS BW IN CM.(1:6)
 5. D.P.C.-P.C.C.(1:1.5:3)+2% C.I.C.O.
 6. FLOOR FINISH IN SITU MOSAIC OR MOSAIC TILES.
 7. DOORS & WINDOWS STEEL CHOWKHAT & STEEL FRAME SHUTTER.
 8. WALL FINISH 0.012M TH. CEMENT PLASTER ON BOTH SIDE PAINTED INSIDE DRY DISTEMPER & SNOWCEM

SCHEDULE OF DOORS & WINDOWS

TYPE	WIDTH	HT.	SILL	DESCRIPTION
D1	900	2100	0.00	SAL WOOD FRAME
D2	750	2100	0.00	PANEL SHUTTER
D3	1050	2100	0.00	PANEL SHUTTER
W1	1500	1200	900	SAL WOOD FRAME
W2	1200	1200	900	SAL WOOD FRAME
W3	900	1200	900	GLAZED SHUTTER
V	600	600	1500	

AREA CALCULATION

PLOT AREA AS PER SITE	=	606.63 SQM
GROUND FLOOR AREA	=	98.39 SQM
FIRST FLOOR AREA	=	98.39 SQM
TOTAL COVERED AREA	=	192.78 SQM
F.A.R	=	0.32
% GROUND COVERAGE	=	15.88%

PROPOSED RESIDENTIAL BUILDING OF
SMT SUNITA STELLA KULUR W/O BIPIN KULUR
VILLAGE-BLOCK COLONY KUTMU, THANA NO. 247,
.THANA - LOHARDAGA, WARD NO-04,
DIST LOHARDAGA, R.S PLOT NO. 861, NEW PLOT NO 973
KHATA NO 44, NEW KHATA NO -192.

SIGNATURE OF APPLICANT'S _____ REGD. LICENCE NO. _____

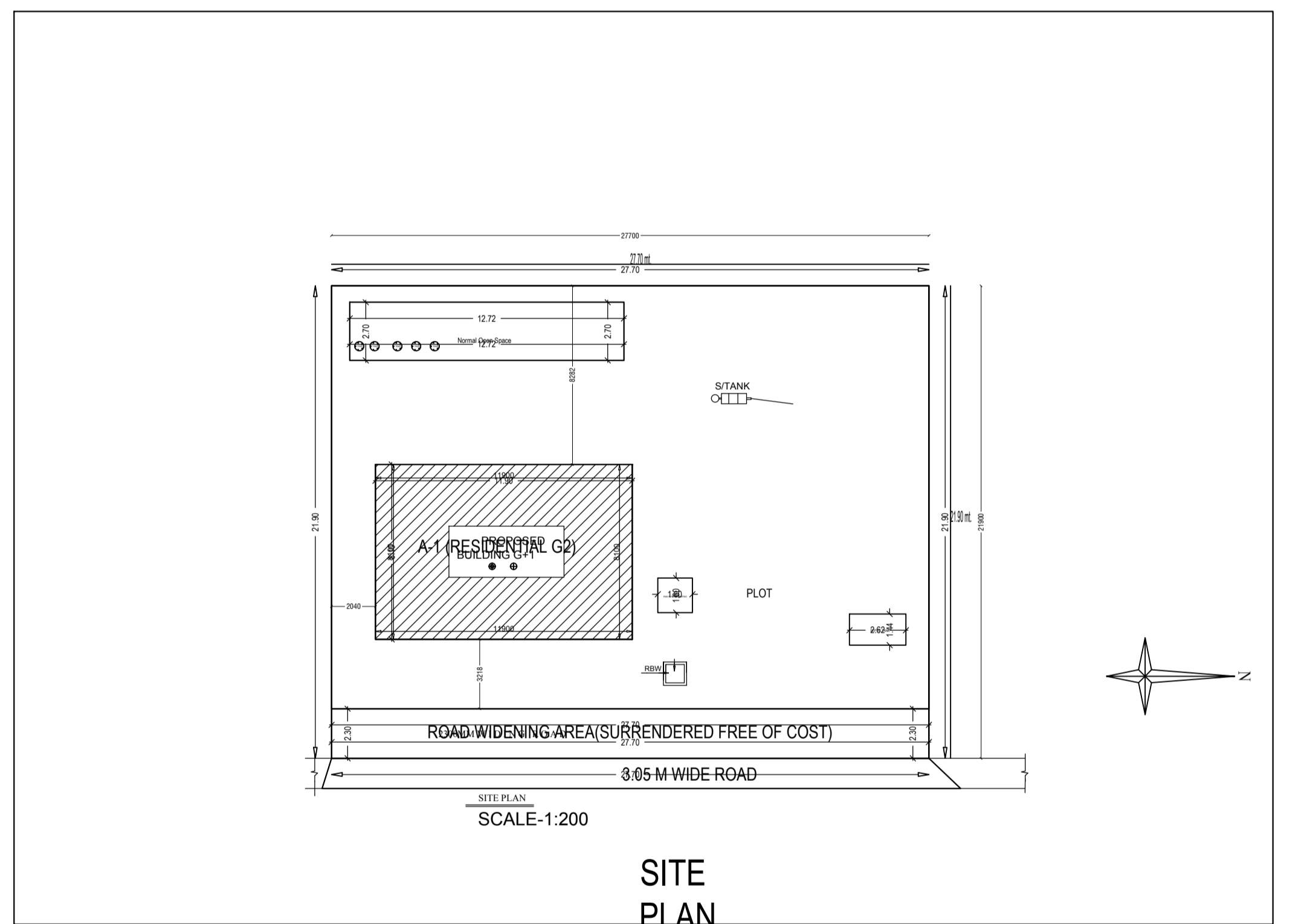
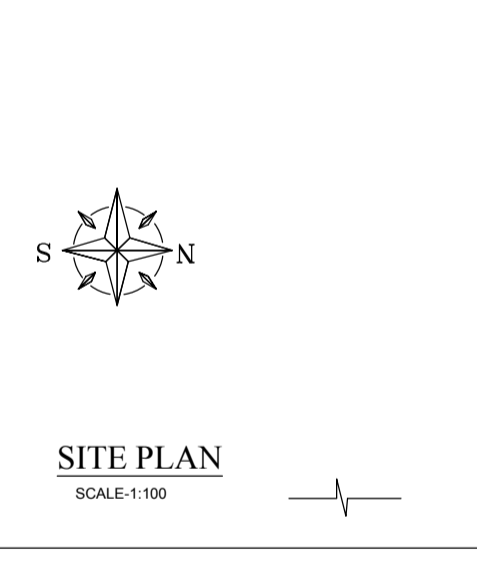
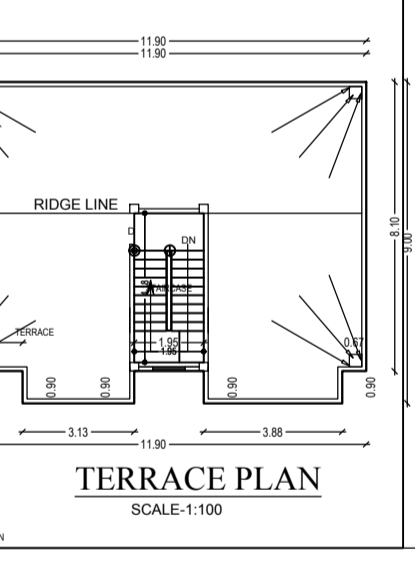
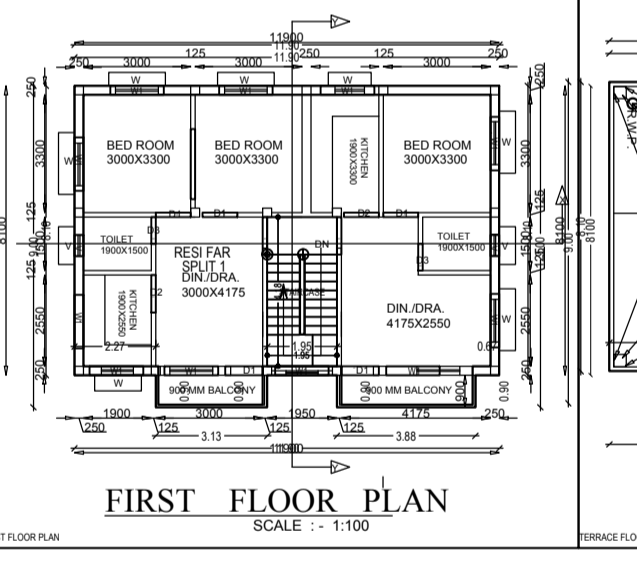
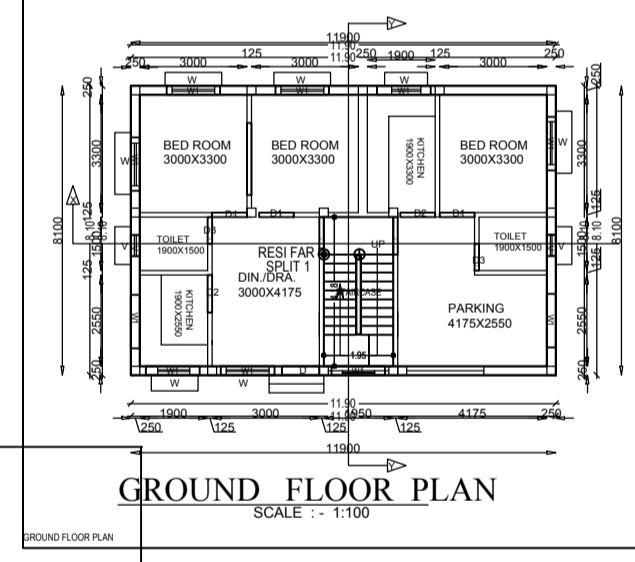

PROJECT DETAILS

NO.	DESCRIPTION	UNIT	QUANTITY
1	Plot Area	SQM	606.63
2	Ground Floor Area	SQM	98.39
3	First Floor Area	SQM	98.39
4	Total Covered Area	SQM	192.78
5	F.A.R		0.32
6	% Ground Coverage		15.88

COLOR INDEX

NO.	DESCRIPTION	UNIT	QUANTITY
1	Plot Area	SQM	606.63
2	Ground Floor Area	SQM	98.39
3	First Floor Area	SQM	98.39
4	Total Covered Area	SQM	192.78
5	F.A.R		0.32
6	% Ground Coverage		15.88

Building A (RESIDENTIAL G2)

FLOOR	Name	Area (Sq.M)	Volume (Cu.M)	% of Area	% of Volume
GROUND FLOOR	RESIDENTIAL G2	98.39	192.78	16.38	31.78
FIRST FLOOR	RESIDENTIAL G2	98.39	192.78	16.38	31.78
TERRACE	RESIDENTIAL G2	98.39	192.78	16.38	31.78

SCHEDULE OF JOINTS

JOINT NO.	Location	Height	Notes
1	Between G2 and G1	2.10	
2	Between G1 and G0	2.10	
3	Between G0 and G-1	2.10	

SCHEDULE OF JOINTS

JOINT NO.	Location	Height	Notes
1	Between G2 and G1	2.10	
2	Between G1 and G0	2.10	
3	Between G0 and G-1	2.10	

UNBIA Table for Building A (RESIDENTIAL G2)

FLOOR	Name	Area (Sq.M)	Volume (Cu.M)	% of Area	% of Volume
GROUND FLOOR	RESIDENTIAL G2	98.39	192.78	16.38	31.78
FIRST FLOOR	RESIDENTIAL G2	98.39	192.78	16.38	31.78
TERRACE	RESIDENTIAL G2	98.39	192.78	16.38	31.78