

Project Title :

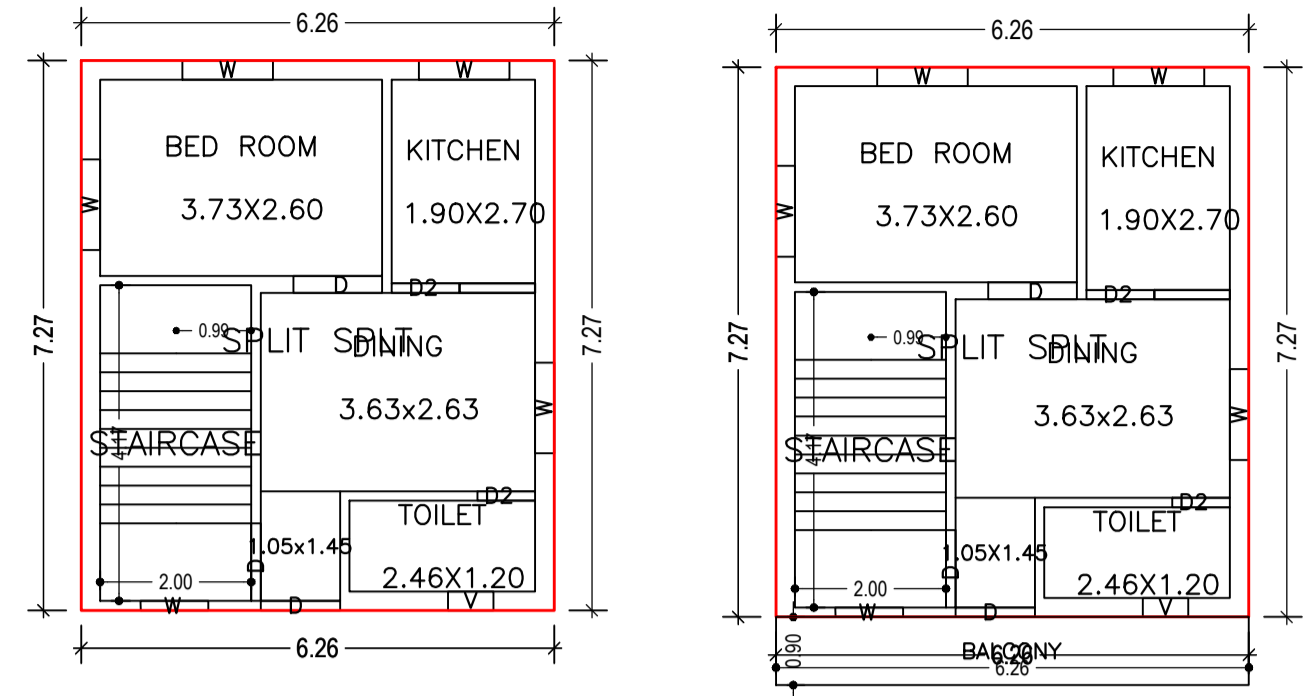

GROUND FLOOR PLAN (Proposed) (SCALE 1:100)

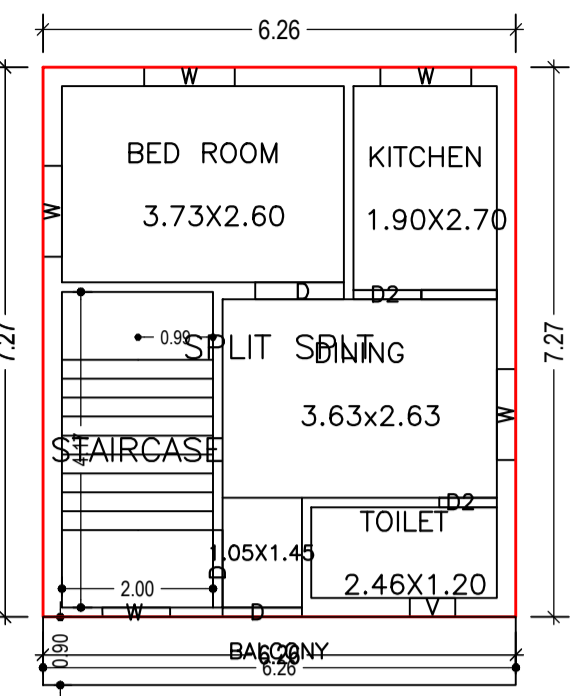

FIRST FLOOR PLAN (Proposed) (SCALE 1:100)

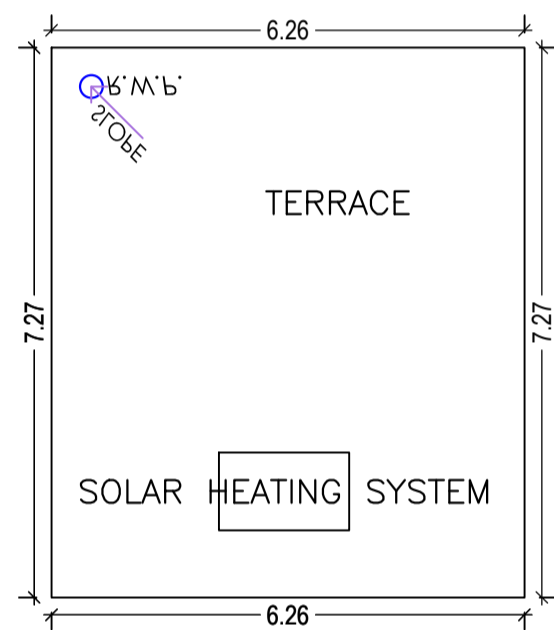

TERRACE FLOOR PLAN (SCALE 1:100)

FAR & Tenement Details (Table 4c-1)

Building	No. of Same Bldg	Total Built Up Area (Sq.mt.)	Deductions (Area in Sq.mt.)	Proposed FAR Area (Sq.mt.)	Total FAR Area (Sq.mt.)	Total Consumed Additional FAR Area (Sq.mt.)	Trmt (No.)
ABC (ABC1)	1	96.60	2.82	93.78	93.78	93.78	01
Grand Total :	1	96.60	2.82	93.78	93.78	93.78	01

Building USE/SUBUSE Details

Building Name	Building Use	Building SubUse	Building Structure
ABC (ABC1)	Residential	Residential Bldg/Apartment	Non-Highrise

UnitBUA Table for Building :ABC (ABC1)

FLOOR	Name	UnitBUA Type	UnitBUA Area	Carpet Area	No. of Rooms	No. of Tenement
GROUND FLOOR PLAN	SPLIT SPLIT	FLAT	60.45	60.20	4	1
FIRST FLOOR PLAN	SPLIT SPLIT	FLAT	0.00	0.00	4	0
Total :	-	-	60.45	60.20	8	1

Buildingwise Floor FAR Details

Floor Name	Building Name		Total	
	Proposed Built Up Area (Sq.mt.)	Proposed FAR Area (Sq.mt.)	Total Proposed Built Up Area (Sq.mt.)	Total FAR Area (Sq.mt.)
Ground Floor	45.48	45.48	45.48	45.48
First Floor	51.12	48.30	51.12	48.30
Terrace Floor	0.00	0.00	0.00	0.00
Total :	96.60	93.78	96.60	93.78

COLOR INDEX

PLOT BOUNDARY	Black
ABUTTING ROAD	Green
PROPOSED CONSTRUCTION	Red
COMMON PLOT	Yellow
ROAD WIDENING AREA	Blue
EXISTING (To be retained)	Light Blue
EXISTING (To be demolished)	Light Yellow

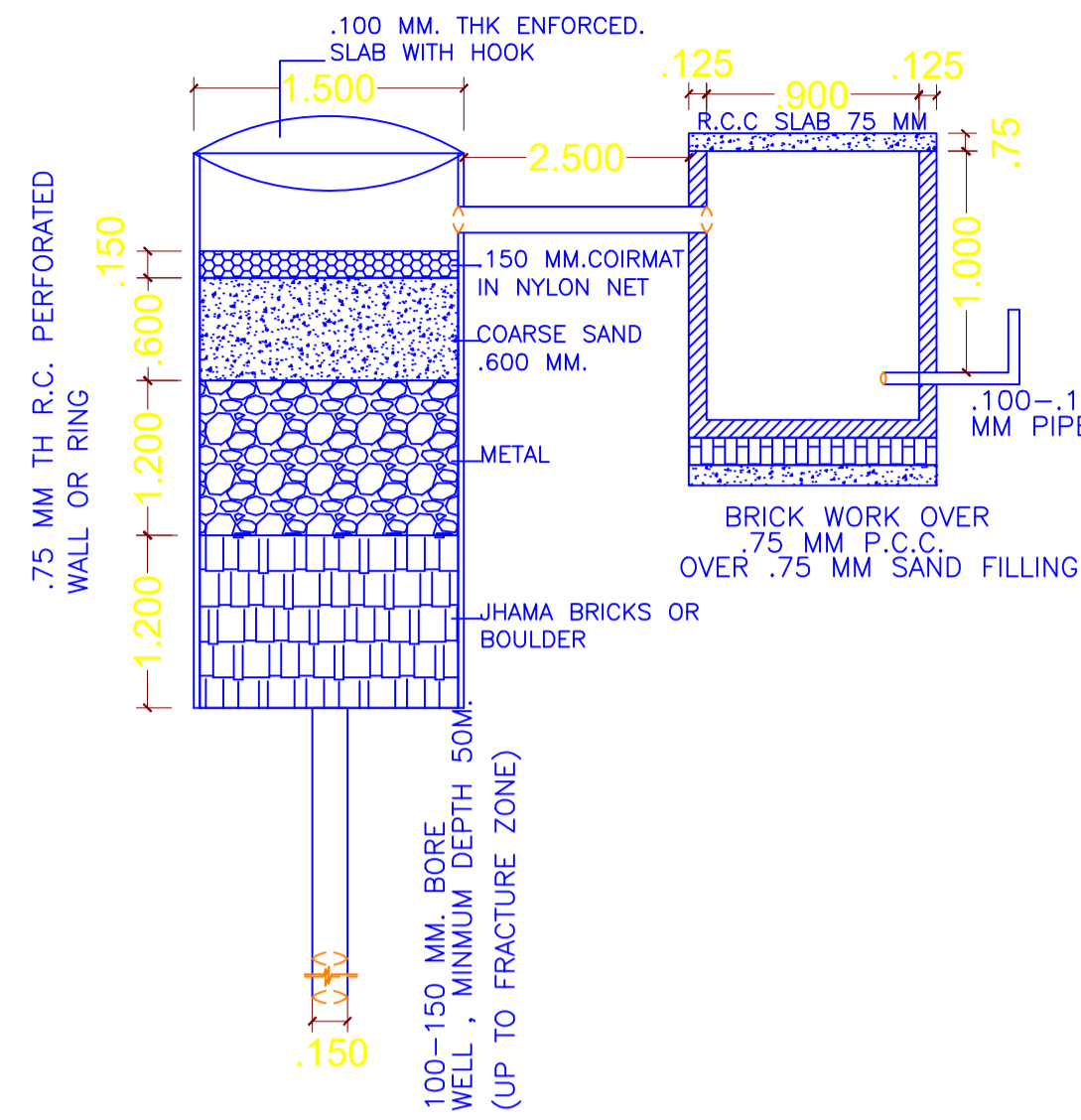

DETAIL OF GROUND WATER RECHARGING PIT WITH SLIT TANK (SCALE 1:50)

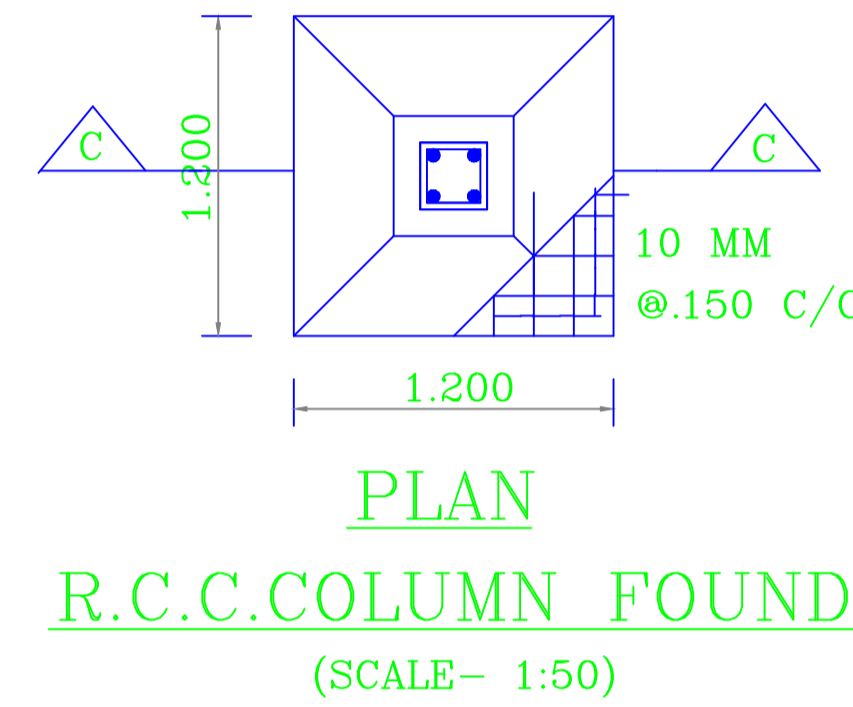

PLAN R.C.C COLUMN FOUNDN. (SCALE 1:50)

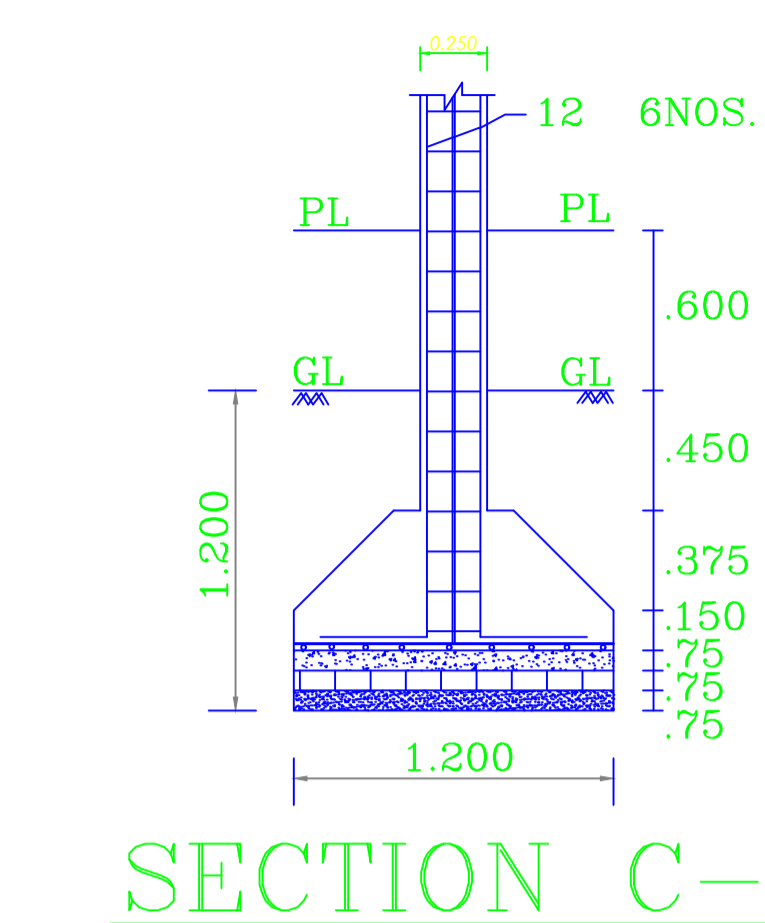

SECTION C-C

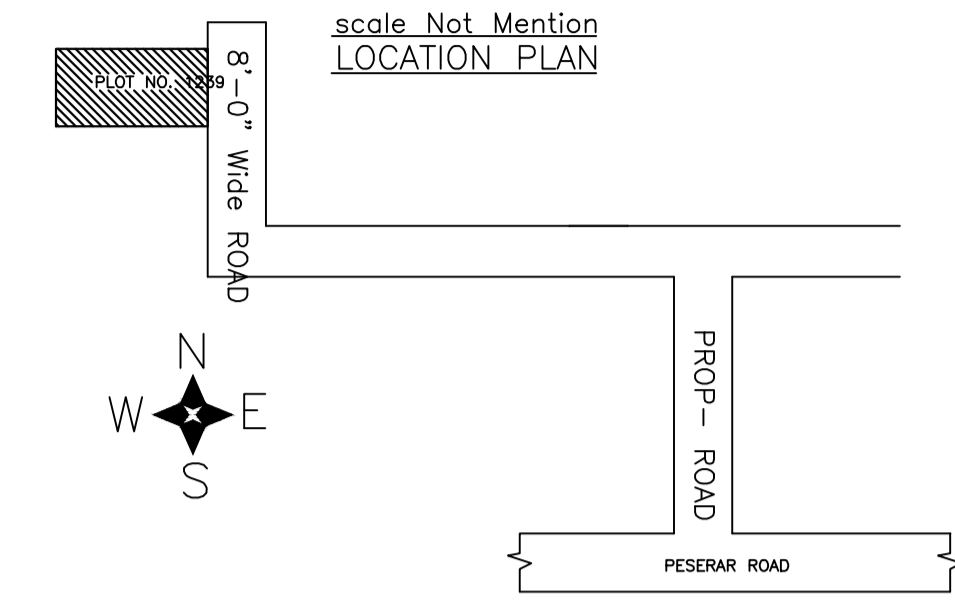

LOCATION & KEY PLAN (SCALE 1:100)

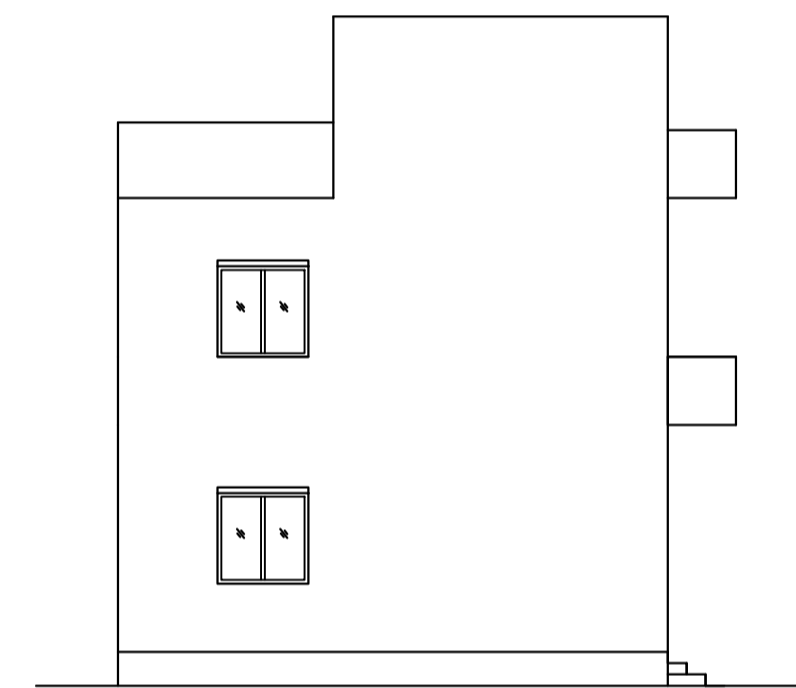

RIGHT SIDE ELEVATION (SCALE 1:100)

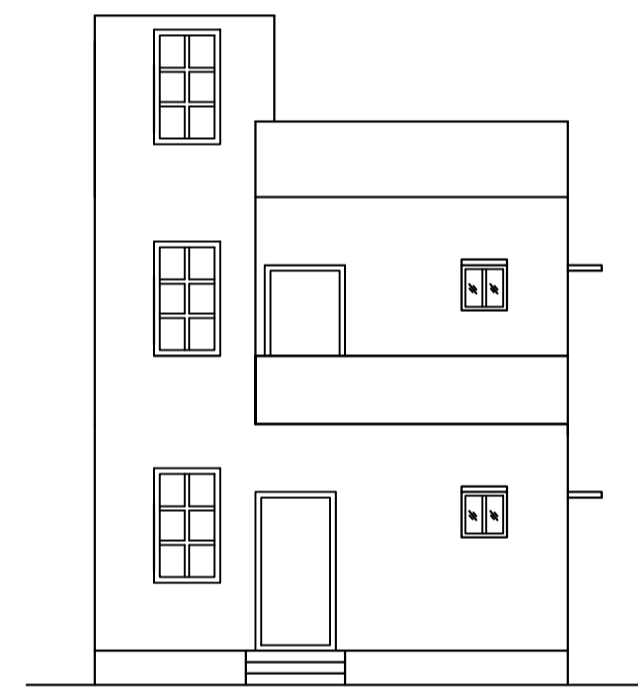

FRONT ELEVATION (SCALE 1:100)

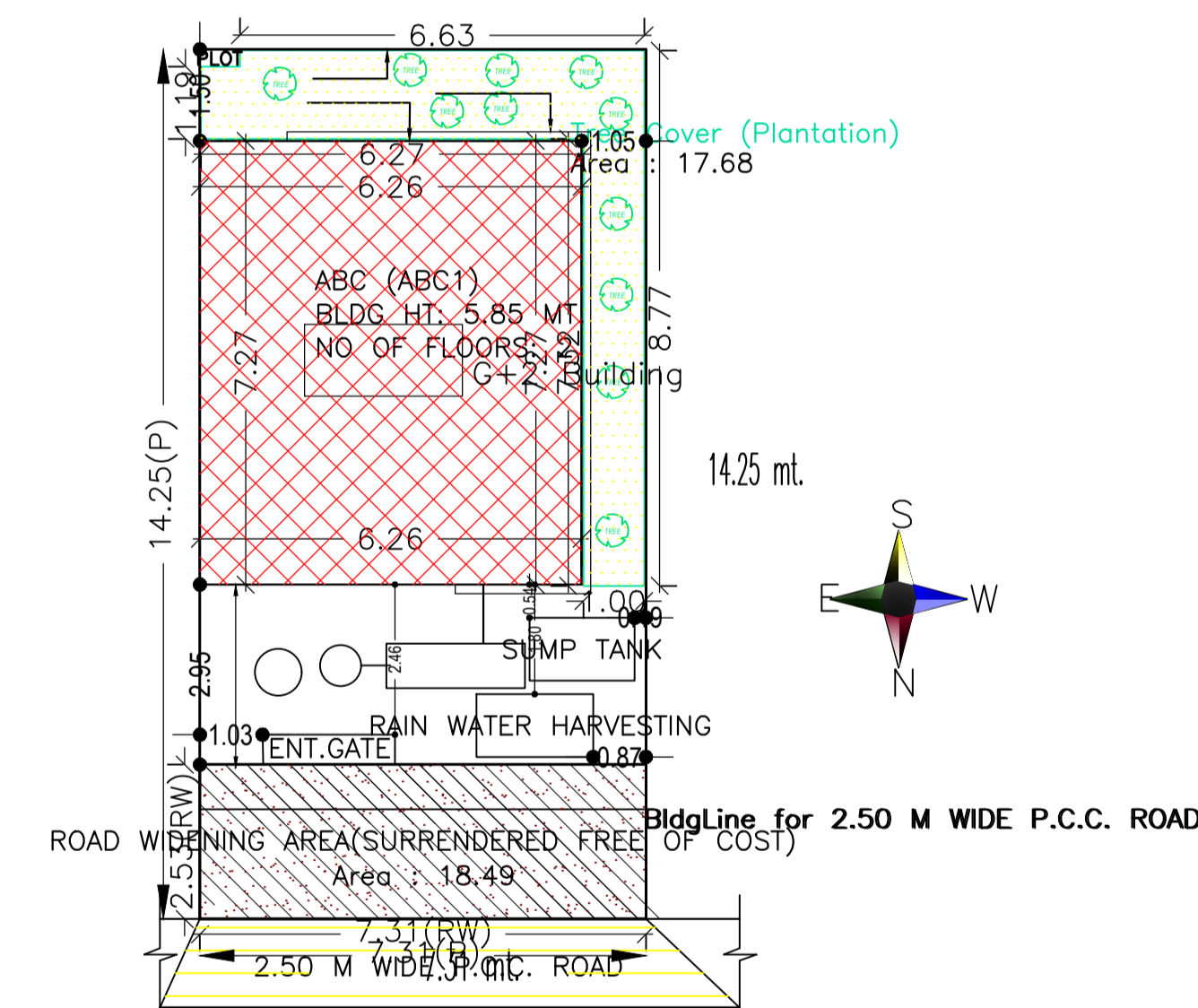

SITE PLAN (SCALE 1:100)

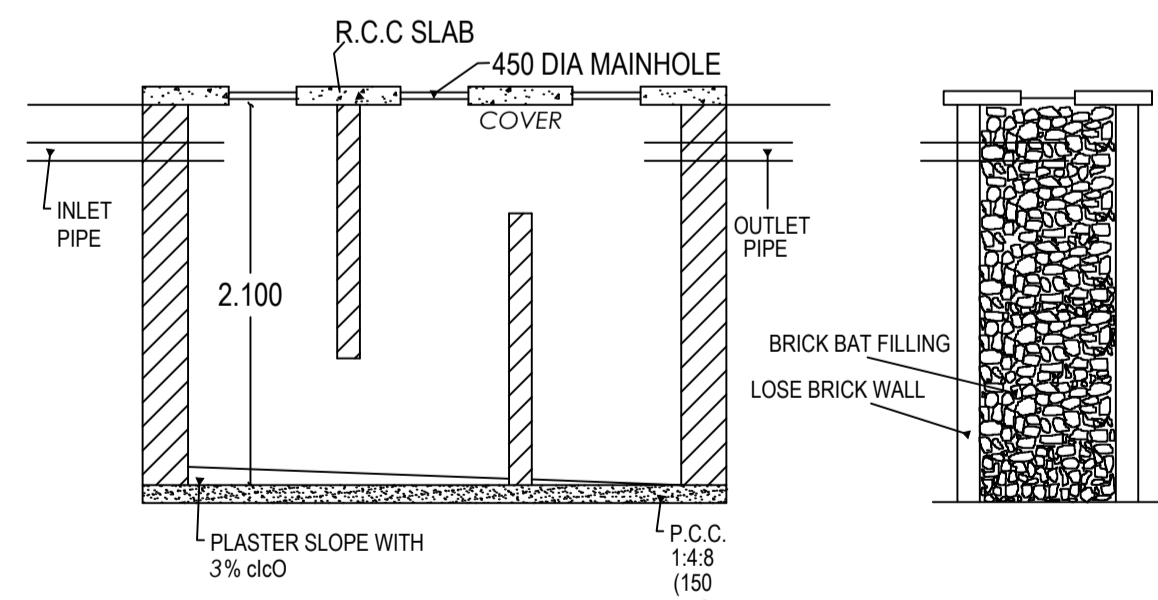

SECTION N-N

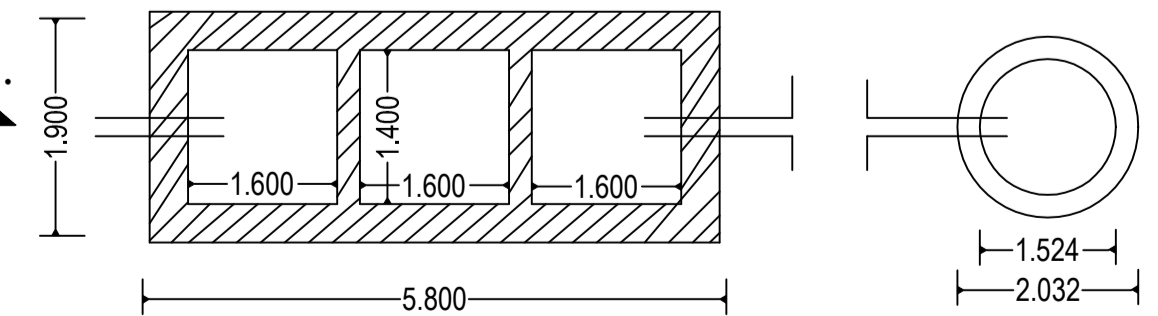

DETAIL OF SEPTIC TANK & SOAKPIT

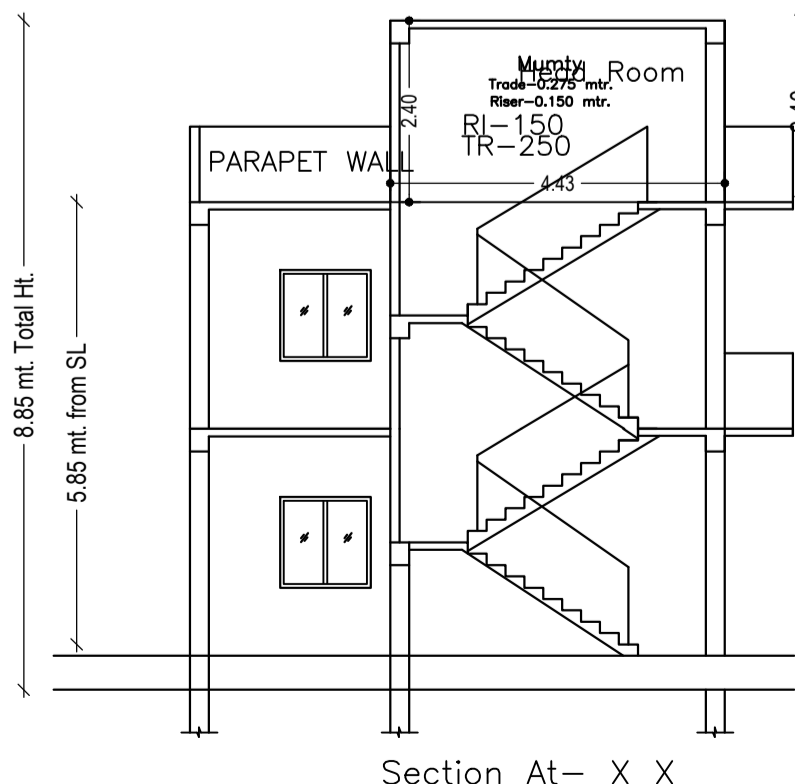

Section At-X X

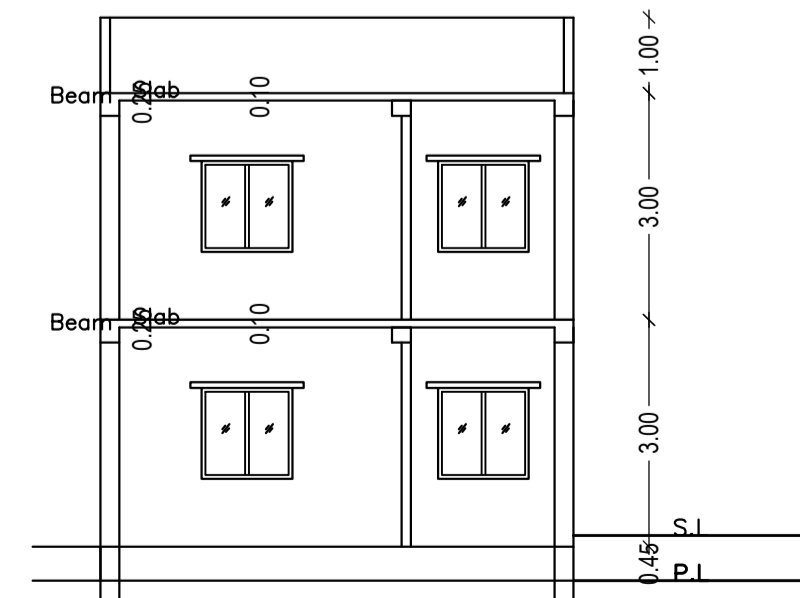

Section At-YY

Proposal Basic Information

Proposal File No.	LNP/0018/W01/2022
Owner Name	SUFIYA KHATOON
Khata No.	07
Plot No.	2239
Village Name	Nigni
Use	Residential
SubUse	Bungalow/ Dwelling / Non Apartment

Balcony Calculations Table

FLOOR	SIZE	AREA	TOTAL AREA
FIRST FLOOR PLAN	0.90 X 6.26 X 1 X 1	5.63	5.63
Total	-	-	5.63

Building :ABC (ABC1)

Floor Name	Total Built Up Area (Sq.mt.)	Deductions (Area in Sq.mt.)	Proposed FAR Area (Sq.mt.)	Total FAR Area (Sq.mt.)	Total Consumed Additional FAR Area (Sq.mt.)	Trmt (No.)
Ground Floor	45.48	0.00	45.48	45.48	45.48	01
First Floor	51.12	2.82	48.30	48.30	48.30	00
Terrace Floor	0.00	0.00	0.00	0.00	0.00	00
Total :	96.60	2.82	93.78	93.78	93.78	01
Total Number of Same Buildings :	1					
Total :	96.60	2.82	93.78	93.78	93.78	01

SCHEDULE OF DOOR:

BUILDING NAME	NAME	LENGTH	HEIGHT	NOS
ABC (ABC1)	D2	0.76	2.10	02
ABC (ABC1)	D2	0.90	2.10	02
ABC (ABC1)	D	1.03	2.10	02
ABC (ABC1)	D	1.05	2.10	02
ABC (ABC1)	D	1.18	2.10	02

SCHEDULE OF WINDOW/VENTILATION:

BUILDING NAME	NAME	LENGTH	HEIGHT	NOS
ABC (ABC1)	V	0.60	1.20	02
ABC (ABC1)	W	0.90	1.20	02
ABC (ABC1)	W	1.20	1.20	08

AREA STATEMENT LOHARDAGA NAGAR PARISHAD

VERSION NO.: 1.0.62
VERSION DATE: 16/10/2020

PROJECT DETAIL:

Region: JHARKHAND URBAN LOCAL BODIES
District: LOHARDAGA
Authority: LOHARDAGA NAGAR PARISHAD
Inward No: LNP/0018/W01/2022
Application Type: General Proposal
Project Type: Building Permission
Nature of Development: New
Location of Development Area: Old Area

Plot Use: Residential
Plot SubUse: Bungalow/ Dwelling / Non Apartment
PlotNearby/ReligiousStructure: NA
Plot/SubPlot No: 2239
North: -
South: -
East: -
West: -

AREA DETAILS:

AREA OF PLOT (Minimum)	(A)	SQ.MT.
Area of Plot	104.02	104.02
Deduction for NetPlot Area		
Surrender Free of Cost		18.49
Total		18.49
NET AREA OF PLOT(Gross Plot Area - Deduction from Gross Plot area)	(A-Deductions)	85.53
Deduction for Balance Plot Area(from Gross Plot Area)		
Surrender Free of Cost		18.49
Common Plot		17.68
Total		36.17
BALANCE AREA OF PLOT(Net Plot Area - Recreational/Amenity space)	(A-Deductions)	67.85
PLOT AREA FOR COVERAGE(Net Plot Area + RoadWidening Area)	(A-Deductions)	85.53
Plot Area for FAR (Net Plot Area + RoadWidening Area)	(A-Deductions)	104.02
COVERAGE CHECK		
Permissible Coverage area (70.00 %)		59.87
Proposed Coverage Area (53.18 %)		45.48
Total Prop. Coverage Area (53.18 %)		45.48
Balance coverage area (16.83 %)		14.39
FAR CHECK		
Perm. FAR Area (1.20)		124.82
Total Perm. FAR area		124.82
Residential FAR		93.78
Proposed FAR Area		93.78
Total Proposed FAR Area		93.78
Consumed FAR (Factor)		0.90
Balance FAR Area		31.04
BUILT UP AREA CHECK		
Total Proposed BuiltUp Area		96.60
ARCHITECT (Regd)	SUNIL KUMAR	
ENGINEER (Regd)		
SUPERVISOR (Regd)		
OWNER (Regd)	SUFIYA KHATOON	
DEVELOPMENT AUTHORITY	LOCAL BODY	

LTP NAME AND SIGNATURE	STRUCTURAL ENG'S NAME AND SIGNATURE	BUILDER NAME AND SIGNATURE	DIGITAL SIGNATURE
SUNIL KUMAR LNP/ENG/0004/2017			