

Project Title : Proposed Residential Building Plan For Mukesh Dubey

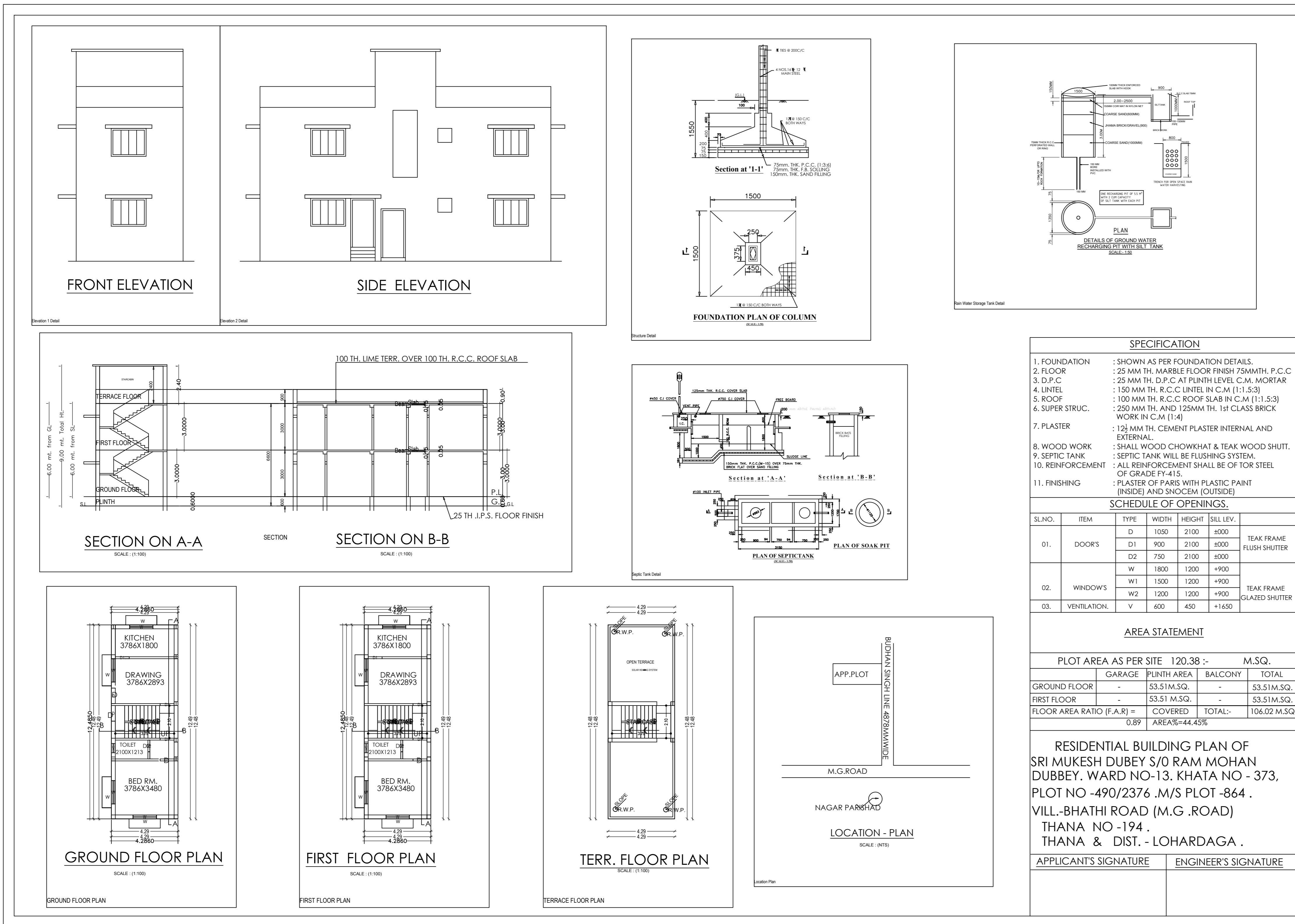

SPECIFICATION

- FOUNDATION : SHOWN AS PER FOUNDATION DETAILS.
- FLOOR : 25 MM TH. MARBLE FLOOR FINISH 75MMTH. P.C.C
- D.P.C. : 25 MM TH. D.P.C. AT PLINTH LEVEL C.M. MORTAR
- LINTEL : 150 MM TH. R.C.C. LINTEL IN C.M (1:1.5:3)
- ROOF : 100 MM TH. R.C.C. ROOF SLAB IN C.M (1:1.5:3)
- SUPER STRUC. : 250 MM TH. AND 125MM TH. 1st CLASS BRICK WORK IN C.M (1:4)
- PLASTER : 125 MM TH. CEMENT PLASTER INTERNAL AND EXTERNAL.
- WOOD WORK : SMALL WOOD CHOWKHAT & TEAK WOOD SHUTT.
- SEPTIC TANK : SEPTIC TANK WILL BE FLUSHING SYSTEM.
- REINFORCEMENT : ALL REINFORCEMENT SHALL BE OF TOR STEEL OF GRADE (Fe415).
- FINISHING : PLASTER OF PARIS WITH PLASTIC PAINT (INSIDE) AND SMOCKEN (OUTSIDE)

SCHEDULE OF OPENINGS

SL.NO.	ITEM	TYPE	WIDTH	HEIGHT	SILL LEV.	
01.	DOORS	D1	1050	2100	+000	TEAK FRAME FLUSH SHUTTER
		D2	900	2100	+000	
		D3	750	2100	+000	
		W	1800	1200	+900	
02.	WINDOWS	W1	1500	1200	+900	TEAK FRAME GLAZED SHUTTER
		W2	1200	1200	+900	
03.	VENTILATION	V	600	450	+1650	

AREA STATEMENT

	AREA (SQ.M)	TOTAL
GROUND FLOOR	53.51 M.SQ.	53.51 M.SQ.
FIRST FLOOR	53.51 M.SQ.	53.51 M.SQ.
FLOOR AREA RATIO (F.A.R) = COVERED	106.02 M.SQ.	
0.89	AREA% = 44.43%	

RESIDENTIAL BUILDING PLAN OF SRI MUKESH DUBEY S/O RAM MOHAN DUBBEY, WARD NO-13, KHATA NO - 373, PLOT NO -490/2376 .M/S PLOT -864 . VILL-BHATHI ROAD (M.G.ROAD) THANA NO -194 . THANA & DIST. - LOHARDAGA .

APPLICANT'S SIGNATURE _____ ENGINEER'S SIGNATURE _____

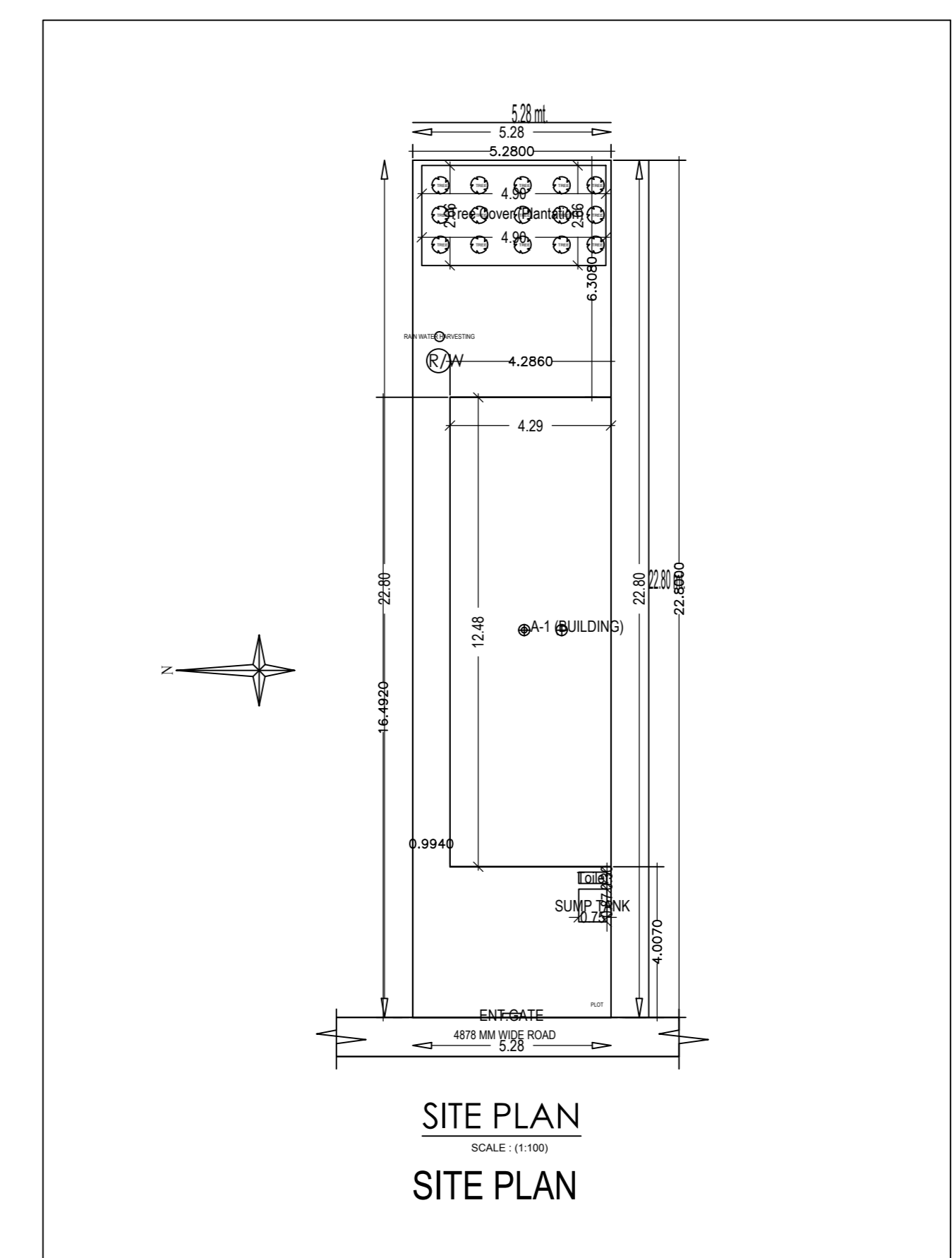

AREA STATEMENT (CONTINUED)

ITEM	AREA (SQ.M)	REMARKS
Plot Area	120.38	
Area of Building	106.02	
Area of Terrace	14.36	
Area of Ramp	0.00	
Area of Road	0.00	
Area of Open Space	0.00	
Area of Other	0.00	
Total	120.38	

TABLE DETAILS

ITEM	AREA (SQ.M)	REMARKS
Area of Floor Slab	53.51	
Area of Wall	106.02	
Area of Column	0.00	
Area of Foundation	0.00	
Area of Terrace	14.36	
Area of Ramp	0.00	
Area of Road	0.00	
Area of Open Space	0.00	
Area of Other	0.00	
Total	120.38	

COLOR INDEX

COLOR	DESCRIPTION
White	Plaster of Paris
Red	Marble
Green	Teak
Blue	Plastic Paint

TABLE INDEX

TABLE NO.	DESCRIPTION
1	Specification
2	Schedule of Openings
3	Area Statement
4	Site Plan

Building A (BUILDING)

Floor Name	Total Built up Area (Sq.M)	Proposed FAR Area (Sq.M)	Total FAR Area (Sq.M)	Scale (No.)
Ground Floor	53.51	53.51	53.51	01
First Floor	53.51	53.51	53.51	02
Total	107.02	107.02	107.02	01

SCHEDULE OF JOINERY

ITEM	NAME	LENGTH	HEIGHT	NO.
FLOORING	WOOD	0.75	2.15	08
	PLASTER	0.75	2.15	08
WALL	WOOD	1.00	2.15	08
	PLASTER	1.00	2.15	08

UphBIA Table for Building A (BUILDING)

FLOOR	Name	UphBIA Type	UphBIA Area	Cost Area	No. of Rooms	No. of Treatment
GROUND FLOOR PLAN	FLAT	01	107.02	107.02	01	1
		02	107.02	107.02	01	1