

Project Title :G+2 residential building

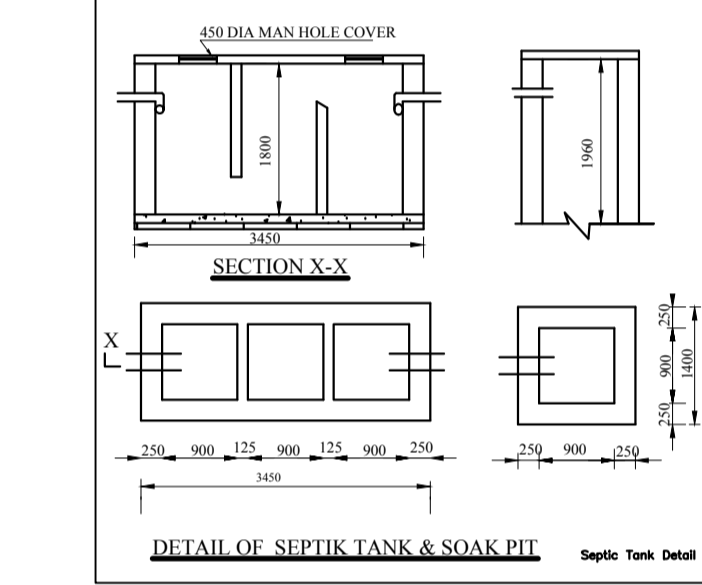
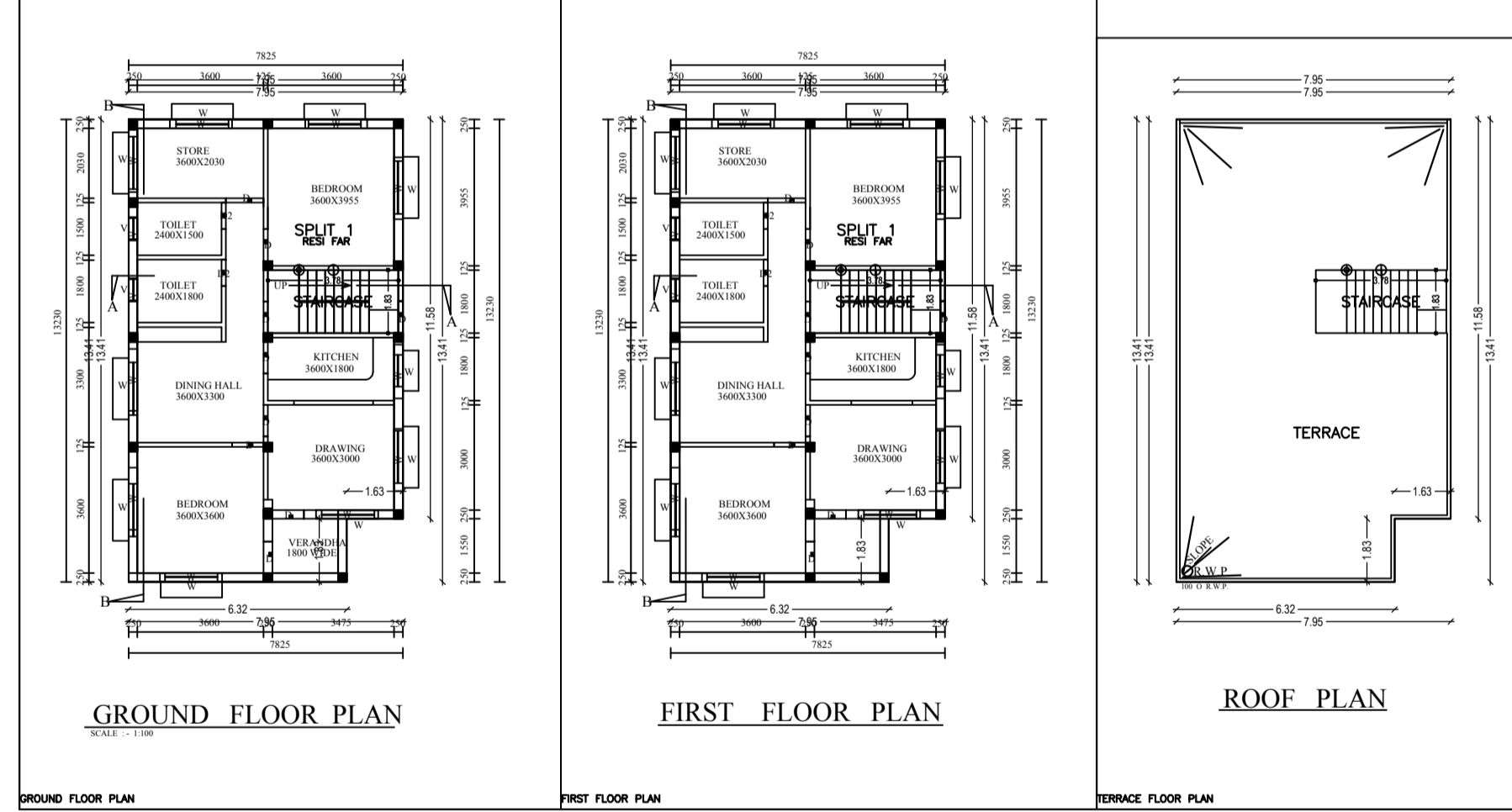
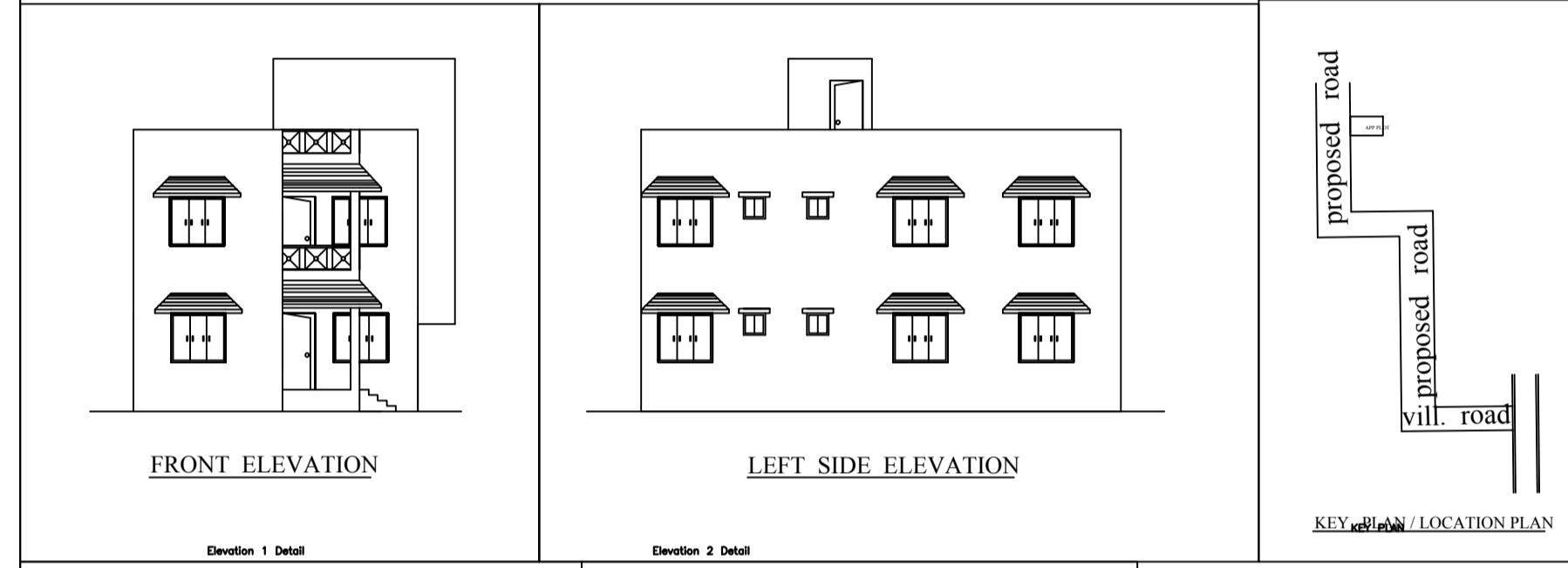
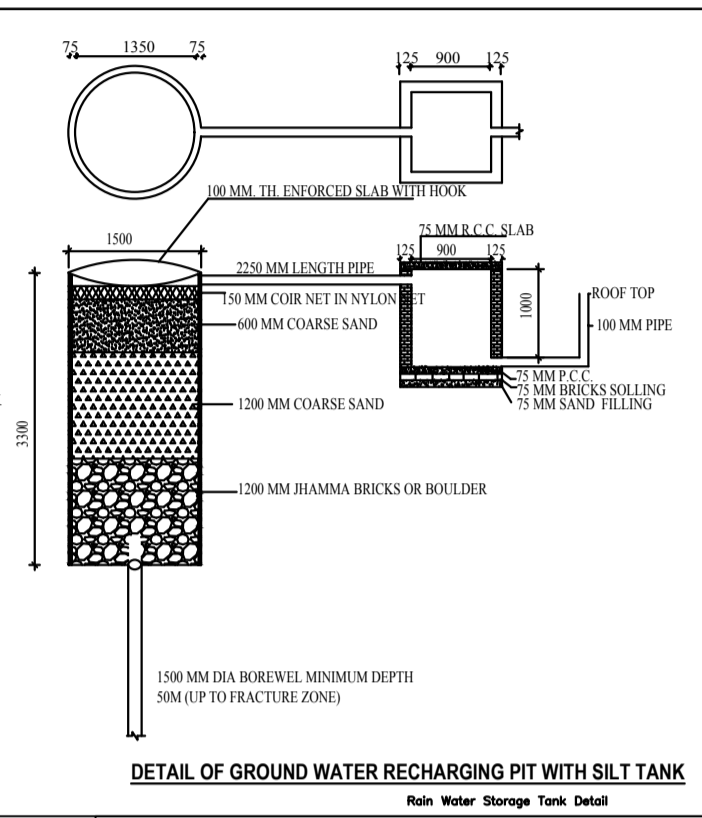
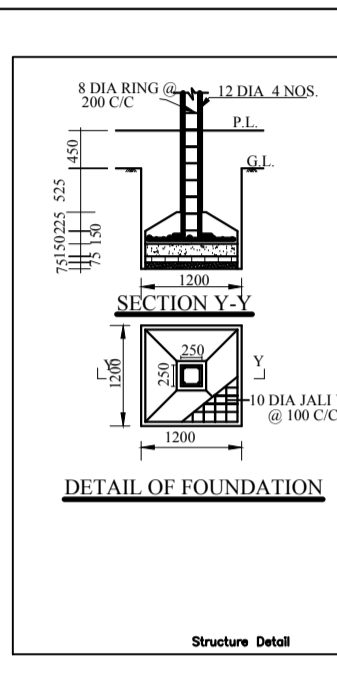
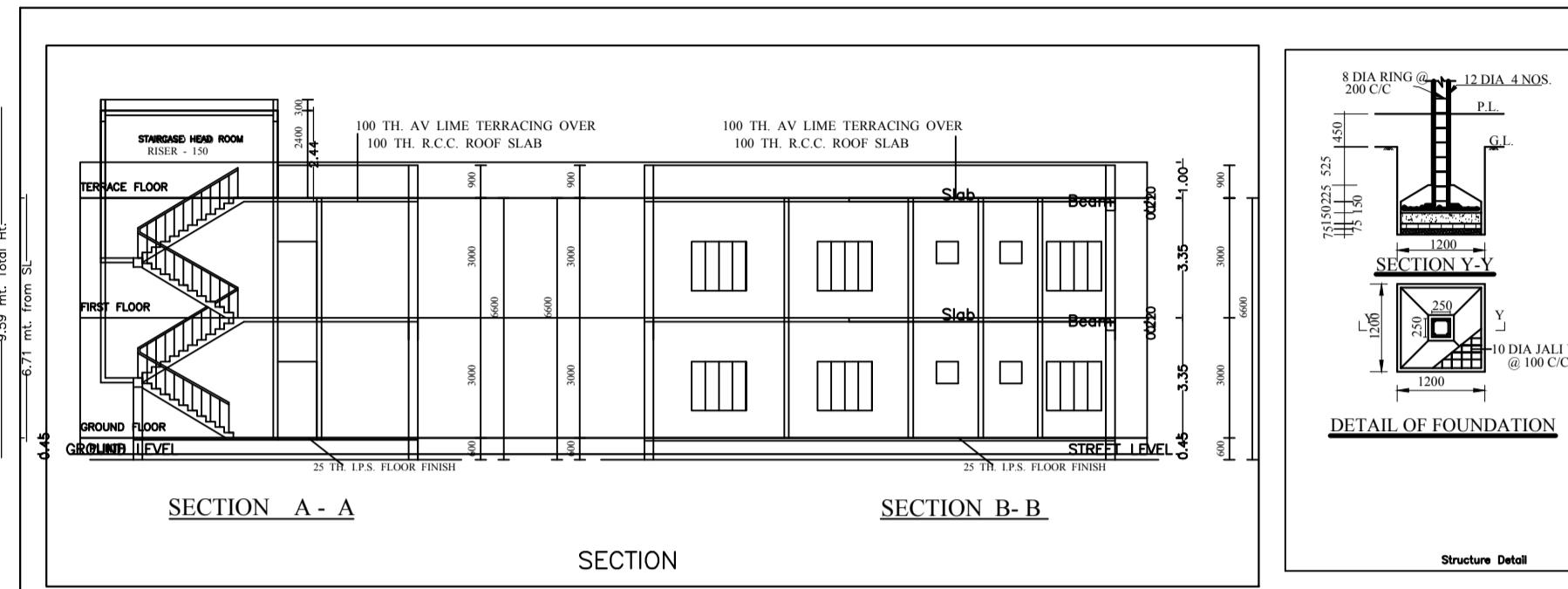

SPECIFICATION

FOUNDATION :- SHOWN IN DETAIL OF FOOTING & COLUMN FLOOR :- 25 TH FLOOR FINISH OVER 75 TH P.C.C. D.P.C. :- 25 TH D.P.C. AT PLINTH EVL IN C.M. LINTEL :- 150 TH R.C.C. LINTEL IN C.C. (1:2:4) ROOF :- 100 TH R.C.C. ROOF SLAB IN C.C. (1:2:4) SUPER STRUCTURE :- 250 TH OR 125 TH 1-ST CLASS BRICK WORK IN CEMENT MORTAR (1:6) PLASTER :- 12 TH CEMENT PLASTER INTERNAL & EXTERNAL SURFACE OF THE WALL (1:6) & 7 TH FOR CEILING (1:4) WOOD WORK :- SAL WOOD CHAIKCHAT & VINA WOOD SHUTTER SEWERAGE DISPOSAL :- THROUGH SEPTIC TANK FINISHING :- 2 COAT OF WHITE WASH SNOWSEM WASH

SCHEDULE OF DOORS&WINDOWS

S.L.NO.	ITEM	WIDTH	HEIGHT	SILL LVL	
1.	DOORS				
	D	1050	2100	0	
	D1	900	2100	0	
	D2	750	2100	0	
2.	WINDOWS				
	W1	1500	1350	750	
	W2	900	1200	900	
3.	VENTILATOR	V	750	600	1500
4.	GLAZING	G	600	1800	750

AREA STATEMENT

PLOT AREA = 200.21 M²
 BUILT UP AREA = M²
 GROUND FLOOR AREA = 103.52 M²
 FIRST FLOOR AREA = 103.52 M²
 TOTAL = 207.04 M²

F.A.R. = 1.0
 % OF COVERED AREA = $\frac{103.52 \times 100}{200.21} = 51.65\%$

PROPOSED RESIDENTIAL BUILDING OF SRI KARTIK KUMAR MAHTO S/O SUKHNATH MAHTO ON OVER R. S. PLOT NO. 1238 KHATA NO 353 WARD NO -22. VILL - BID PRAM NAGER THANA NO. 194 THANA - LOHARDAGA. DIST- LOHARDAGA

SIGN OF APPLICANT SIGN OF LIC/ENGG

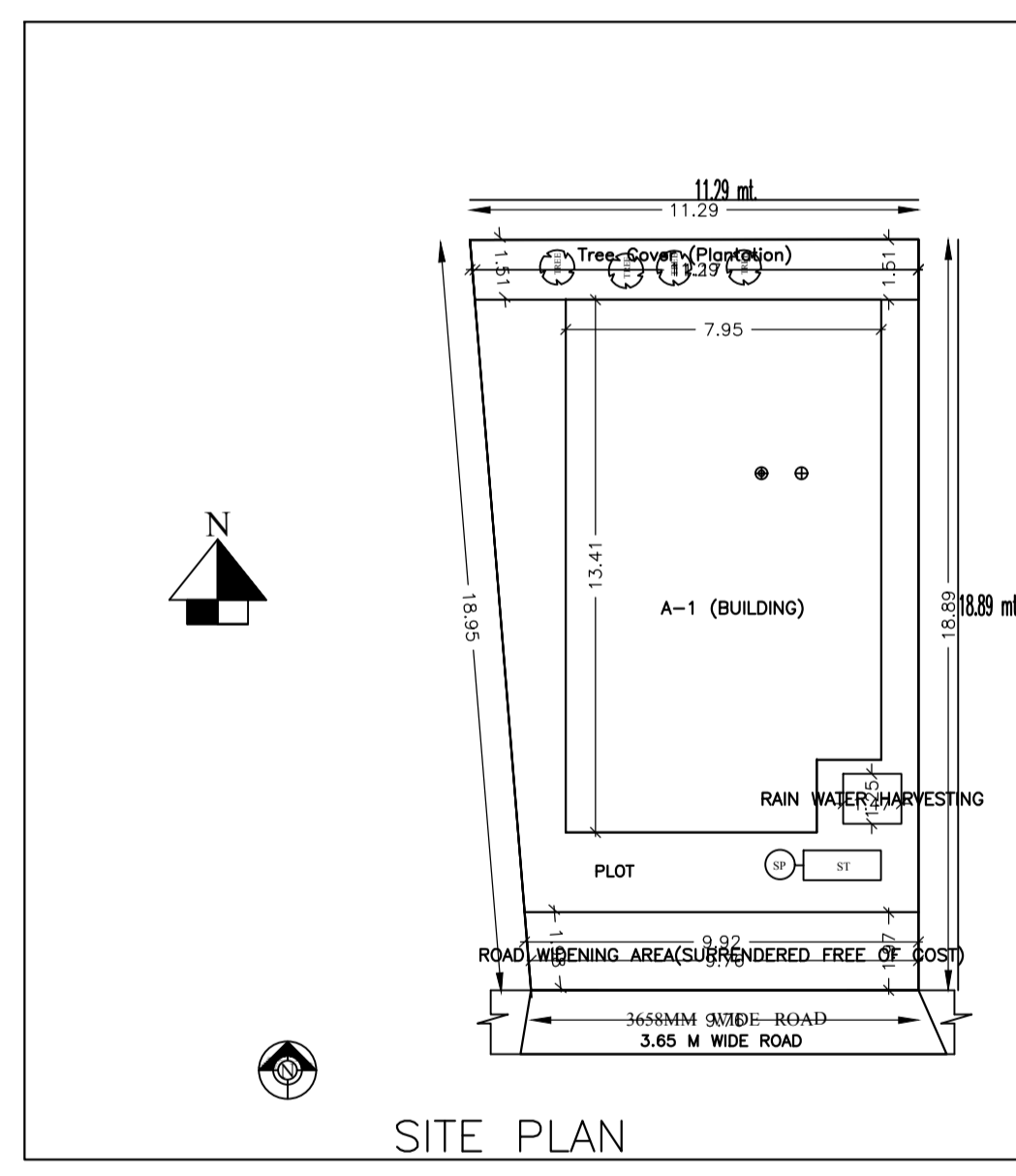

AREA STATEMENT (LOHARDAGA NAGER PARISHAD) VERSION NO. 1.0.02
 VERSION DATE: 09/02/2025

PROJECT DETAIL	Project No.	Plot No.	Plot Area
Project Name	Project Name	Project Name	Project Name
Project Type	Project Type	Project Type	Project Type
Project Location	Project Location	Project Location	Project Location
Project Status	Project Status	Project Status	Project Status
Project Date	Project Date	Project Date	Project Date
Project Owner	Project Owner	Project Owner	Project Owner
Project Designer	Project Designer	Project Designer	Project Designer
Project Engineer	Project Engineer	Project Engineer	Project Engineer
Project Supervisor	Project Supervisor	Project Supervisor	Project Supervisor
Project Inspector	Project Inspector	Project Inspector	Project Inspector
Project Approver	Project Approver	Project Approver	Project Approver
Project Signatory	Project Signatory	Project Signatory	Project Signatory
Project Seal	Project Seal	Project Seal	Project Seal
Project Stamp	Project Stamp	Project Stamp	Project Stamp
Project Mark	Project Mark	Project Mark	Project Mark
Project Note	Project Note	Project Note	Project Note
Project Remark	Project Remark	Project Remark	Project Remark
Project Comment	Project Comment	Project Comment	Project Comment
Project Observation	Project Observation	Project Observation	Project Observation
Project Suggestion	Project Suggestion	Project Suggestion	Project Suggestion
Project Recommendation	Project Recommendation	Project Recommendation	Project Recommendation
Project Conclusion	Project Conclusion	Project Conclusion	Project Conclusion
Project Summary	Project Summary	Project Summary	Project Summary
Project Final Report	Project Final Report	Project Final Report	Project Final Report
Project Final Drawing	Project Final Drawing	Project Final Drawing	Project Final Drawing
Project Final Approval	Project Final Approval	Project Final Approval	Project Final Approval
Project Final Signatory	Project Final Signatory	Project Final Signatory	Project Final Signatory
Project Final Seal	Project Final Seal	Project Final Seal	Project Final Seal
Project Final Stamp	Project Final Stamp	Project Final Stamp	Project Final Stamp
Project Final Mark	Project Final Mark	Project Final Mark	Project Final Mark
Project Final Note	Project Final Note	Project Final Note	Project Final Note
Project Final Remark	Project Final Remark	Project Final Remark	Project Final Remark
Project Final Comment	Project Final Comment	Project Final Comment	Project Final Comment
Project Final Observation	Project Final Observation	Project Final Observation	Project Final Observation
Project Final Suggestion	Project Final Suggestion	Project Final Suggestion	Project Final Suggestion
Project Final Recommendation	Project Final Recommendation	Project Final Recommendation	Project Final Recommendation
Project Final Conclusion	Project Final Conclusion	Project Final Conclusion	Project Final Conclusion
Project Final Summary	Project Final Summary	Project Final Summary	Project Final Summary
Project Final Final Report	Project Final Final Report	Project Final Final Report	Project Final Final Report
Project Final Final Drawing	Project Final Final Drawing	Project Final Final Drawing	Project Final Final Drawing
Project Final Final Approval	Project Final Final Approval	Project Final Final Approval	Project Final Final Approval
Project Final Final Signatory	Project Final Final Signatory	Project Final Final Signatory	Project Final Final Signatory
Project Final Final Seal	Project Final Final Seal	Project Final Final Seal	Project Final Final Seal
Project Final Final Stamp	Project Final Final Stamp	Project Final Final Stamp	Project Final Final Stamp
Project Final Final Mark	Project Final Final Mark	Project Final Final Mark	Project Final Final Mark
Project Final Final Note	Project Final Final Note	Project Final Final Note	Project Final Final Note
Project Final Final Remark	Project Final Final Remark	Project Final Final Remark	Project Final Final Remark
Project Final Final Comment	Project Final Final Comment	Project Final Final Comment	Project Final Final Comment
Project Final Final Observation	Project Final Final Observation	Project Final Final Observation	Project Final Final Observation
Project Final Final Suggestion	Project Final Final Suggestion	Project Final Final Suggestion	Project Final Final Suggestion
Project Final Final Recommendation	Project Final Final Recommendation	Project Final Final Recommendation	Project Final Final Recommendation
Project Final Final Conclusion	Project Final Final Conclusion	Project Final Final Conclusion	Project Final Final Conclusion
Project Final Final Summary	Project Final Final Summary	Project Final Final Summary	Project Final Final Summary
Project Final Final Final Report	Project Final Final Final Report	Project Final Final Final Report	Project Final Final Final Report
Project Final Final Final Drawing	Project Final Final Final Drawing	Project Final Final Final Drawing	Project Final Final Final Drawing
Project Final Final Final Approval	Project Final Final Final Approval	Project Final Final Final Approval	Project Final Final Final Approval
Project Final Final Final Signatory	Project Final Final Final Signatory	Project Final Final Final Signatory	Project Final Final Final Signatory
Project Final Final Final Seal	Project Final Final Final Seal	Project Final Final Final Seal	Project Final Final Final Seal
Project Final Final Final Stamp	Project Final Final Final Stamp	Project Final Final Final Stamp	Project Final Final Final Stamp
Project Final Final Final Mark	Project Final Final Final Mark	Project Final Final Final Mark	Project Final Final Final Mark
Project Final Final Final Note	Project Final Final Final Note	Project Final Final Final Note	Project Final Final Final Note
Project Final Final Final Remark	Project Final Final Final Remark	Project Final Final Final Remark	Project Final Final Final Remark
Project Final Final Final Comment	Project Final Final Final Comment	Project Final Final Final Comment	Project Final Final Final Comment
Project Final Final Final Observation	Project Final Final Final Observation	Project Final Final Final Observation	Project Final Final Final Observation
Project Final Final Final Suggestion	Project Final Final Final Suggestion	Project Final Final Final Suggestion	Project Final Final Final Suggestion
Project Final Final Final Recommendation	Project Final Final Final Recommendation	Project Final Final Final Recommendation	Project Final Final Final Recommendation
Project Final Final Final Conclusion	Project Final Final Final Conclusion	Project Final Final Final Conclusion	Project Final Final Final Conclusion
Project Final Final Final Summary	Project Final Final Final Summary	Project Final Final Final Summary	Project Final Final Final Summary
Project Final Final Final Final Report	Project Final Final Final Final Report	Project Final Final Final Final Report	Project Final Final Final Final Report
Project Final Final Final Final Drawing	Project Final Final Final Final Drawing	Project Final Final Final Final Drawing	Project Final Final Final Final Drawing
Project Final Final Final Final Approval	Project Final Final Final Final Approval	Project Final Final Final Final Approval	Project Final Final Final Final Approval
Project Final Final Final Final Signatory	Project Final Final Final Final Signatory	Project Final Final Final Final Signatory	Project Final Final Final Final Signatory
Project Final Final Final Final Seal	Project Final Final Final Final Seal	Project Final Final Final Final Seal	Project Final Final Final Final Seal
Project Final Final Final Final Stamp	Project Final Final Final Final Stamp	Project Final Final Final Final Stamp	Project Final Final Final Final Stamp
Project Final Final Final Final Mark	Project Final Final Final Final Mark	Project Final Final Final Final Mark	Project Final Final Final Final Mark
Project Final Final Final Final Note	Project Final Final Final Final Note	Project Final Final Final Final Note	Project Final Final Final Final Note
Project Final Final Final Final Remark	Project Final Final Final Final Remark	Project Final Final Final Final Remark	Project Final Final Final Final Remark
Project Final Final Final Final Comment	Project Final Final Final Final Comment	Project Final Final Final Final Comment	Project Final Final Final Final Comment
Project Final Final Final Final Observation	Project Final Final Final Final Observation	Project Final Final Final Final Observation	Project Final Final Final Final Observation
Project Final Final Final Final Suggestion	Project Final Final Final Final Suggestion	Project Final Final Final Final Suggestion	Project Final Final Final Final Suggestion
Project Final Final Final Final Recommendation	Project Final Final Final Final Recommendation	Project Final Final Final Final Recommendation	Project Final Final Final Final Recommendation
Project Final Final Final Final Conclusion	Project Final Final Final Final Conclusion	Project Final Final Final Final Conclusion	Project Final Final Final Final Conclusion
Project Final Final Final Final Summary	Project Final Final Final Final Summary	Project Final Final Final Final Summary	Project Final Final Final Final Summary

AREA STATEMENT

AREA DETAILS	Area (Sq. M)	Area (Sq. Ft)
Plot Area	200.21	220.00
Built Up Area	207.04	225.00
Ground Floor Area	103.52	112.50
First Floor Area	103.52	112.50
Terrace Area	0.00	0.00
Roof Area	0.00	0.00
Other Area	0.00	0.00
Total Area	207.04	225.00

COLOR INDEX

Color	Description
Red	Proposed Building
Blue	Proposed Road
Green	Proposed Open Green Area
Black	Existing (To be retained)
Grey	Existing (To be demolished)

MARGIN DETAIL

Margin Type	Front Margin	Rear Margin	Side Margin	Setback Margin
Building	2.00	1.00	0.00	1.00

FAR & Tenement Details (Table 4c-1)

Building	No. of Storeys	Total Built Up Area (Sq. M)	Proposed FAR Area (Sq. M)	Total FAR Area (Sq. M)	Street No.
A (BUILDING)	1	207.04	207.04	207.04	01
Grand Total	1	207.04	207.04	207.04	01

Building A (BUILDING)

Floor Name	Total Built Up Area (Sq. M)	Proposed FAR Area (Sq. M)	Total FAR Area (Sq. M)	Tenement No.
Ground Floor	103.52	103.52	103.52	01
First Floor	103.52	103.52	103.52	02
Terrace	0.00	0.00	0.00	03
Total	207.04	207.04	207.04	01

SCHEDULE OF JOINERY:

ITEM	NAME	LENGTH	HEIGHT	NO. OF
A (BUILDING)	W1	1.50	1.20	04
A (BUILDING)	W2	0.75	0.75	04
A (BUILDING)	W3	0.75	0.75	04
A (BUILDING)	W4	0.75	0.75	04
A (BUILDING)	W5	0.75	0.75	04
A (BUILDING)	W6	0.75	0.75	04
A (BUILDING)	W7	0.75	0.75	04
A (BUILDING)	W8	0.75	0.75	04
A (BUILDING)	W9	0.75	0.75	04
A (BUILDING)	W10	0.75	0.75	04
A (BUILDING)	W11	0.75	0.75	04
A (BUILDING)	W12	0.75	0.75	04
A (BUILDING)	W13	0.75	0.75	04
A (BUILDING)	W14	0.75	0.75	04
A (BUILDING)	W15	0.75	0.75	04
A (BUILDING)	W16	0.75	0.75	04
A (BUILDING)	W17	0.75	0.75	04
A (BUILDING)	W18	0.75	0.75	04
A (BUILDING)	W19	0.75	0.75	04
A (BUILDING)	W20	0.75	0.75	04
A (BUILDING)	W21	0.75	0.75	04
A (BUILDING)	W22	0.75	0.75	04
A (BUILDING)	W23	0.75	0.75	04
A (BUILDING)	W24	0.75	0.75	04
A (BUILDING)	W25	0.75	0.75	04
A (BUILDING)	W26	0.75	0.75	04
A (BUILDING)	W27	0.75	0.75	04
A (BUILDING)	W28	0.75	0.75	04
A (BUILDING)	W29	0.75	0.75	04
A (BUILDING)	W30	0.75	0.75	04
A (BUILDING)	W31	0.75	0.75	04
A (BUILDING)	W32	0.75	0.75	04
A (BUILDING)	W33	0.75	0.75	04
A (BUILDING)	W34	0.75	0.75	04
A (BUILDING)	W35	0.75	0.75	04
A (BUILDING)	W36	0.75	0.75	04
A (BUILDING)	W37	0.75	0.75	04
A (BUILDING)	W38	0.75	0.75	04
A (BUILDING)	W39	0.75	0.75	04
A (BUILDING)	W40	0.75	0.75	04
A (BUILDING)	W41	0.75	0.75	04
A (BUILDING)	W42	0.75	0.75	04
A (BUILDING)	W43	0.75	0.75	04
A (BUILDING)	W44	0.75	0.75	04
A (BUILDING)	W45	0.75	0.75	04
A (BUILDING)	W46	0.75	0.75	04
A (BUILDING)	W47	0.75	0.75	04
A (BUILDING)	W48	0.75	0.75	04
A (BUILDING)	W49	0.75	0.75	04
A (BUILDING)	W50	0.75	0.75	04
A (BUILDING)	W51	0.75	0.75	04
A (BUILDING)	W52	0.75	0.75	04
A (BUILDING)	W53	0.75	0.75	04
A (BUILDING)	W54	0.75	0.75	04
A (BUILDING)	W55	0.75	0.75	04
A (BUILDING)	W56	0.75	0.75	04
A (BUILDING)	W57	0.75	0.75	04
A (BUILDING)	W58	0.75	0.75	04
A (BUILDING)	W59	0.75	0.75	04
A (BUILDING)	W60	0.75	0.75	04
A (BUILDING)	W61	0.75	0.75	04
A (BUILDING)	W62	0.75	0.75	04
A (BUILDING)	W63	0.75	0.75	04
A (BUILDING)	W64	0.75	0.75	04
A (BUILDING)	W65	0.75	0.75	04
A (BUILDING)	W66	0.75	0.75	04
A (BUILDING)	W67	0.75	0.75	04
A (BUILDING)	W68	0.75	0.75	04
A (BUILDING)	W69	0.75	0.75	04
A (BUILDING)	W70	0.75	0.75	04
A (BUILDING)	W71	0.75	0.75	04
A (BUILDING)	W72	0.75	0.75	04
A (BUILDING)	W73	0.75	0.75	04
A (BUILDING)	W74	0.75	0.75	04
A (BUILDING)	W75	0.75	0.75	04
A (BUILDING)	W76	0.75	0.75	04
A (BUILDING)	W77	0.75	0.75	04
A (BUILDING)	W78	0.75	0.75	04
A (BUILDING)	W79	0.75	0.75	04
A (BUILDING)	W80	0.75	0.75	04
A (BUILDING)	W81	0.75	0.75	04
A (BUILDING)	W82	0.75	0.75	04
A (BUILDING)	W83	0.75	0.75	04
A (BUILDING)	W84	0.75	0.75	04
A (BUILDING)	W85	0.75	0.75	04
A (BUILDING)	W86	0.75	0.75	04
A (BUILDING)	W87	0.75	0.75	04
A (BUILDING)	W			