

Proposal Basic Information

Proposal File No.	LNP/BP/0020/W22/2022
Owner Name	SHANTI BALA TIRKEY
Khata No	305/140
Plot No	520/462
Village Name	Juriya
Use	Residential
SubUse	Bungalow/ Dwelling / Non Apartment

UnitBUA Table for Building :ABC (123)

FLOOR	Name	UnitBUA Type	UnitBUA Area	Carpet Area	No. of Rooms	No. of Tenement
GROUND FLOOR PLAN	SPLIT SPTS	FLAT	152.38	151.95	6	1
FIRST FLOOR PLAN	SPLIT SPTS	FLAT	0.00	0.00	6	0
Total:	-	-	152.38	151.95	12	1

SCHEDULE OF DOOR:

BUILDING NAME	NAME	LENGTH	HEIGHT	NOS
ABC (123)	D2	0.60	2.10	04
ABC (123)	D1	0.90	2.10	06
ABC (123)	D	1.05	2.10	04

SCHEDULE OF WINDOW/VENTILATION:

BUILDING NAME	NAME	LENGTH	HEIGHT	NOS
ABC (123)	V	0.60	1.20	04
ABC (123)	W2	0.90	1.20	02
ABC (123)	W1	1.20	1.20	02
ABC (123)	W1	1.50	1.20	04
ABC (123)	W	1.80	1.20	02

Buildingwise Floor FAR Details

Floor Name	Building Name ABC (123)		Total	
	Proposed Built Up Area (Sq.mt.)	Proposed FAR Area (Sq.mt.)	Total Proposed Built Up Area (Sq.mt.)	Total FAR Area (Sq.mt.)
Ground Floor	76.19	76.19	76.19	76.19
First Floor	76.19	76.19	76.19	76.19
Terrace Floor	0.00	0.00	0.00	0.00
Total :	152.38	152.38	152.38	152.38

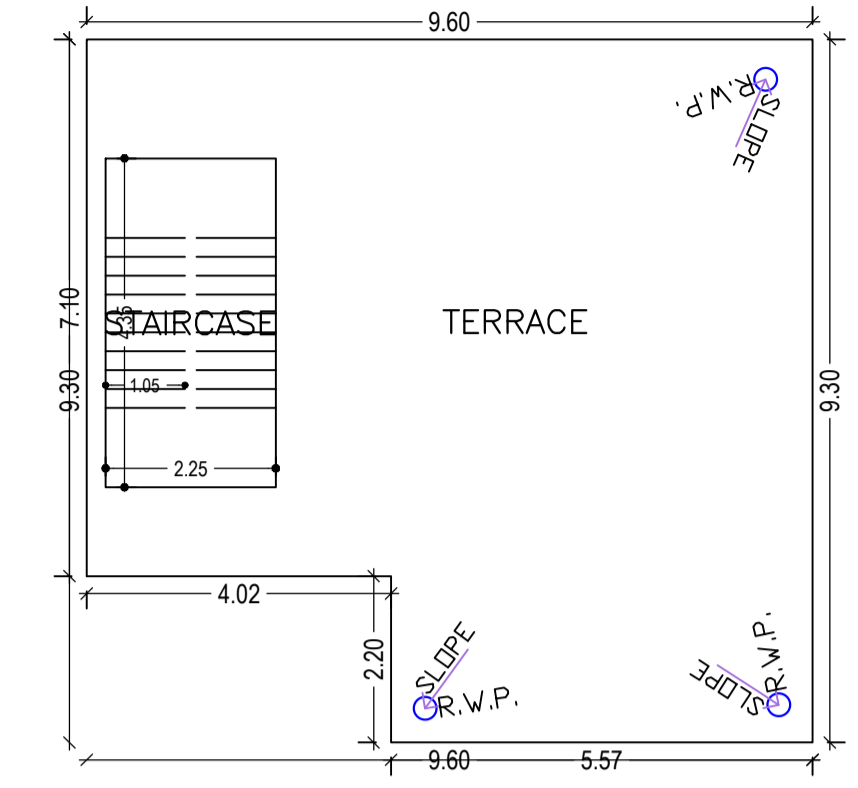
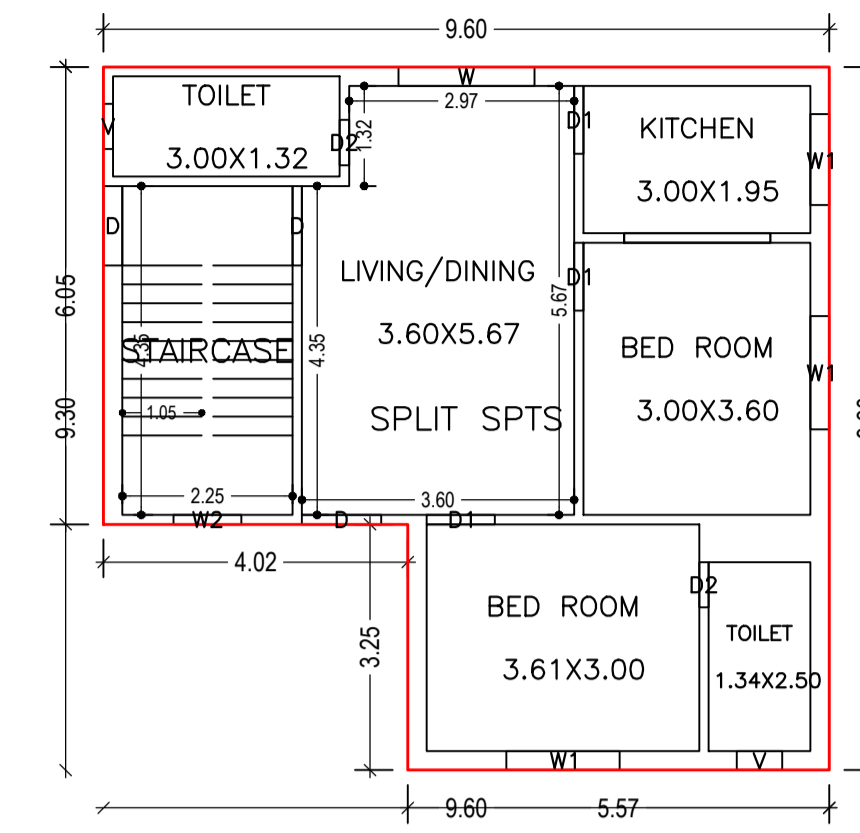
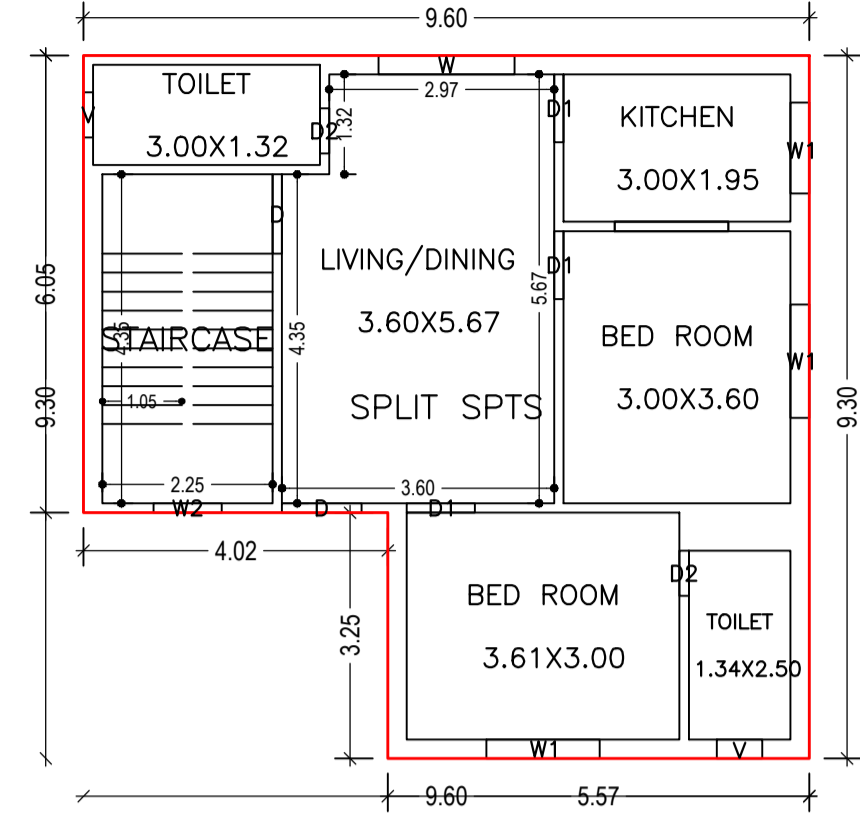
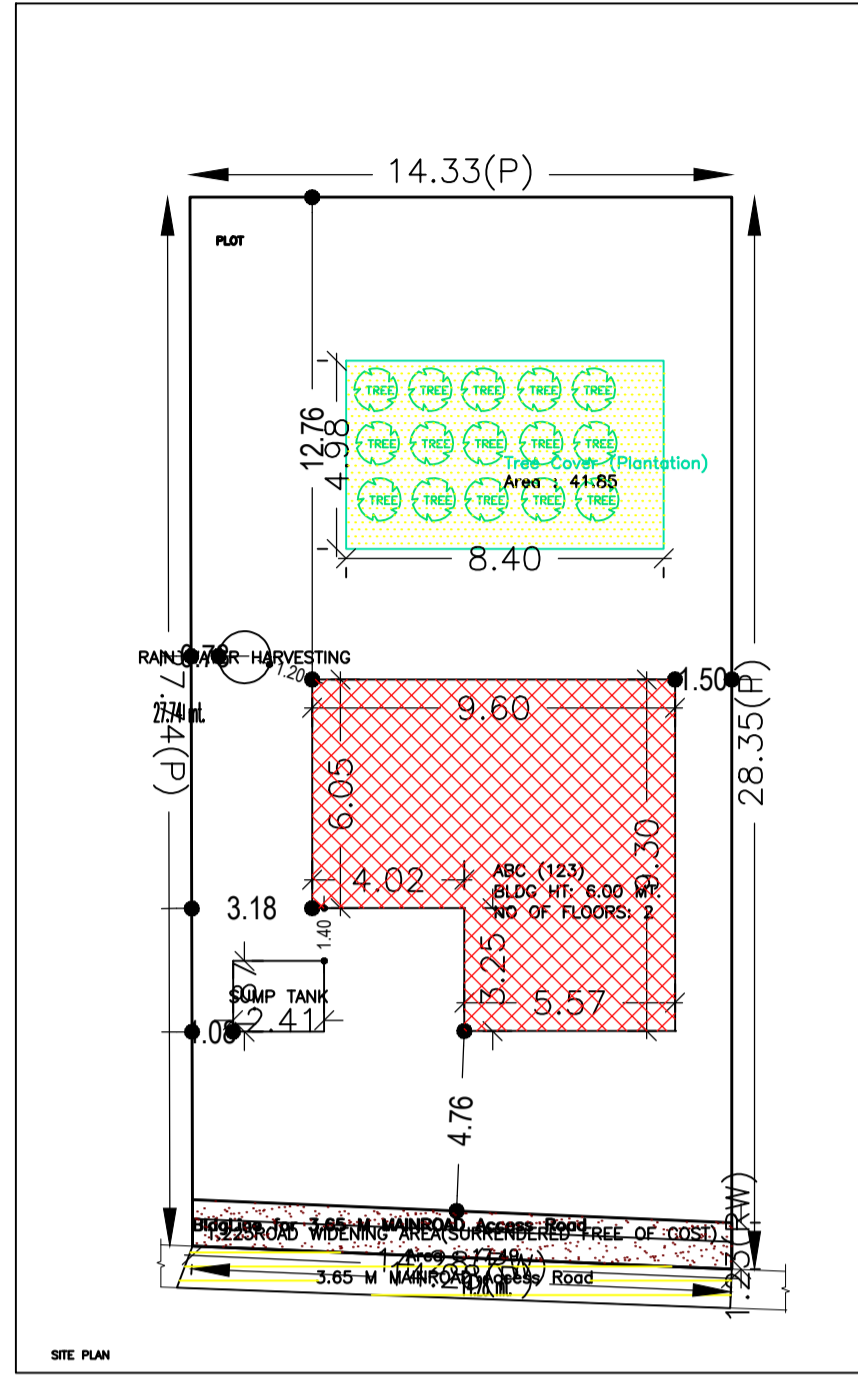

FIRST FLOOR PLAN (Proposed) (SCALE 1:100)

GROUND FLOOR PLAN (Proposed) (SCALE 1:100)

TERRACE FLOOR PLAN (SCALE 1:100)

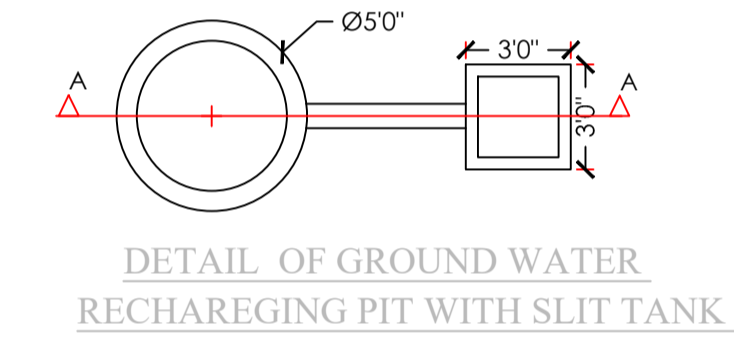
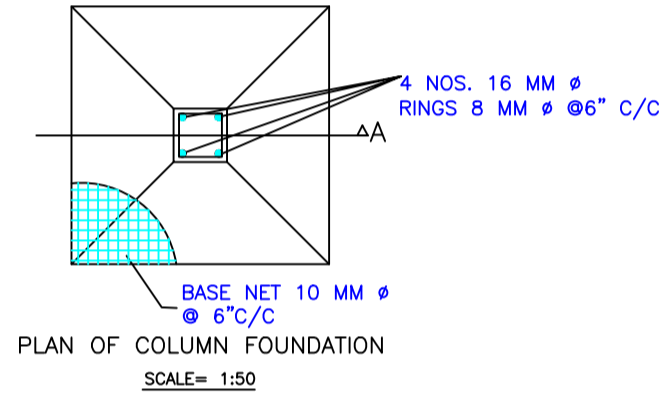
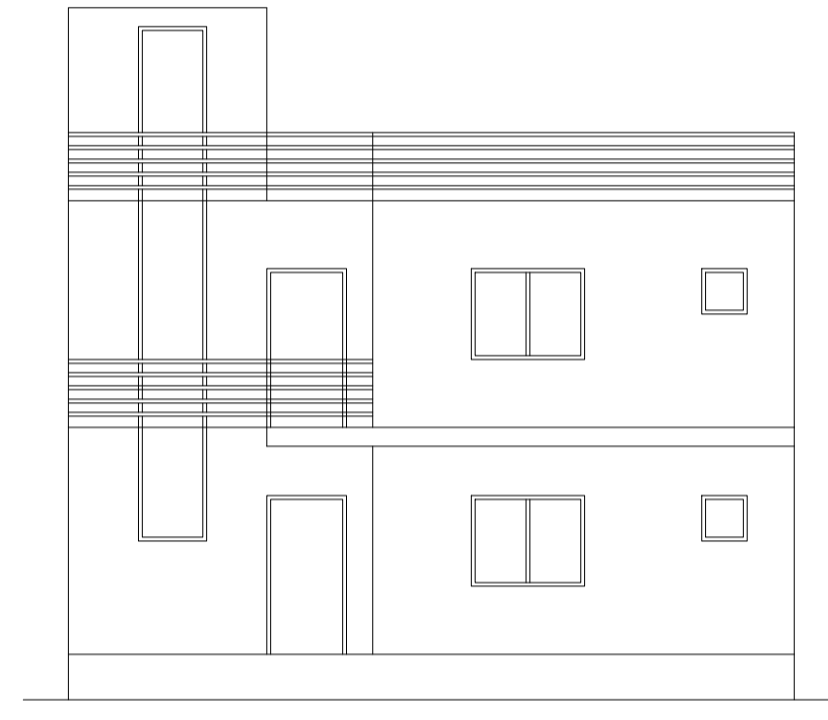

Building USE/SUBUSE Details

Building Name	Building Use	Building SubUse	Building Structure
ABC (123)	Residential	Bungalow/ Dwelling / Non Apartment	Non-Highrise

FAR & Tenement Details (Table 4c-1)

Building	No. of Same Bldg	Total Built Up Area (Sq.mt.)	Proposed FAR Area (Sq.mt.) Resi.	Total FAR Area (Sq.mt.)	Total Consumed Additional FAR Area (Sq.mt.)	Tnmt (No.)
ABC (123)	1	152.38	152.38	152.38	152.38	01
Grand Total :	1	152.38	152.38	152.38	152.38	01

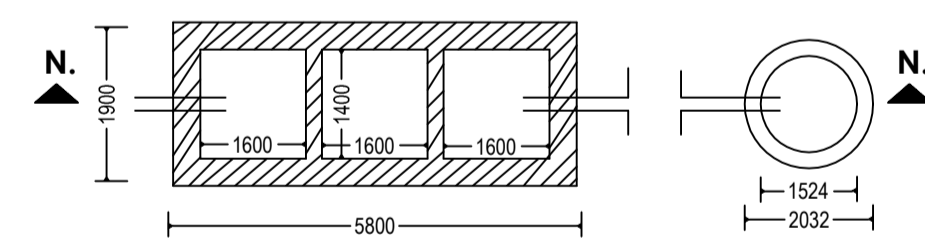
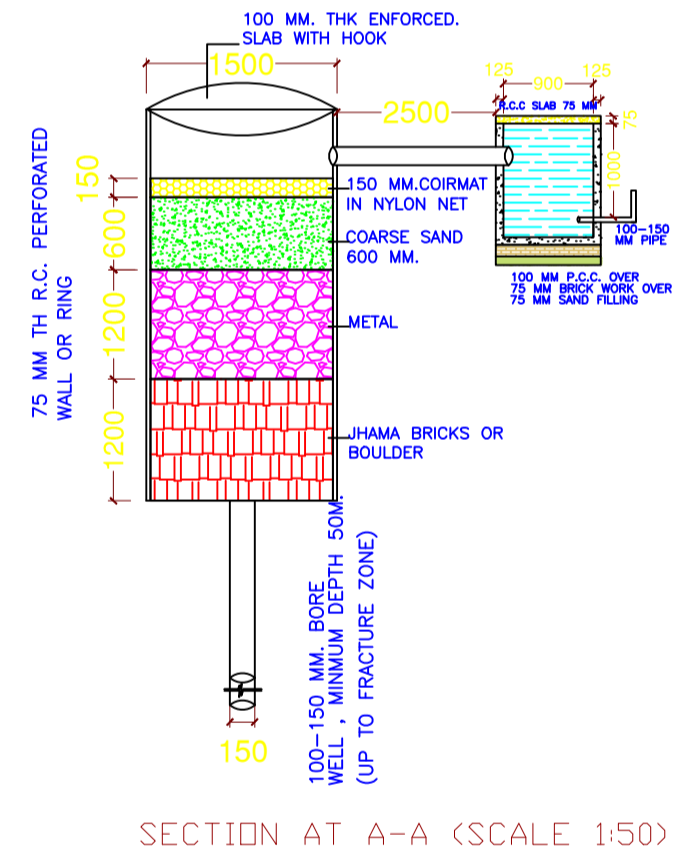
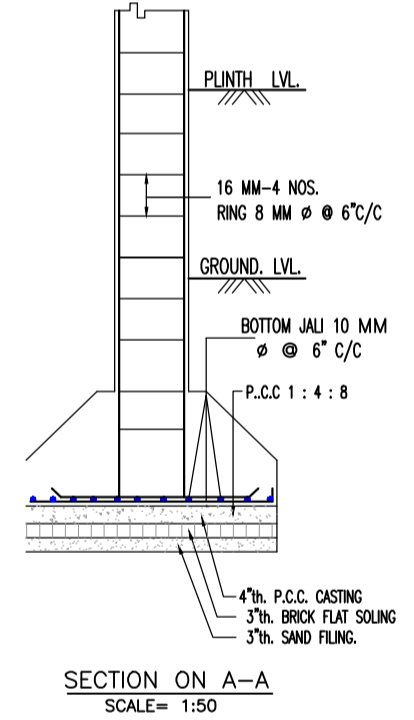
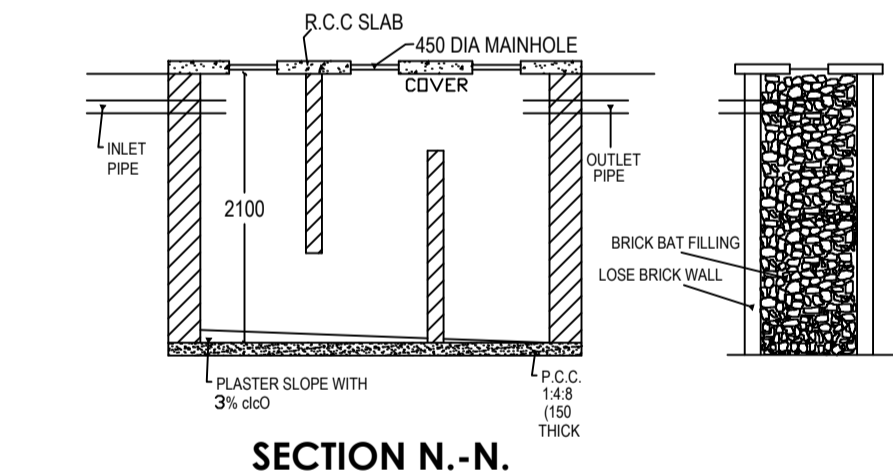

Building :ABC (123)

Floor Name	Total Built Up Area (Sq.mt.)	Proposed FAR Area (Sq.mt.) Resi.	Total FAR Area (Sq.mt.)	Total Consumed Additional FAR Area (Sq.mt.)	Tnmt (No.)
Ground Floor	76.19	76.19	76.19	76.19	01
First Floor	76.19	76.19	76.19	76.19	00
Terrace Floor	0.00	0.00	0.00	0.00	00
Total :	152.38	152.38	152.38	152.38	01
Total Number of Same Buildings	1				
Total :	152.38	152.38	152.38	152.38	01

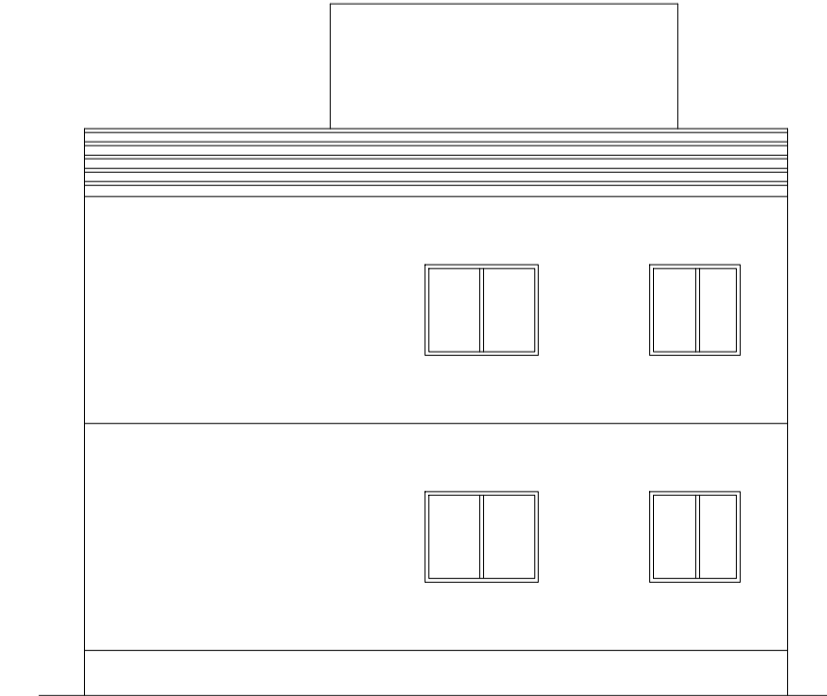
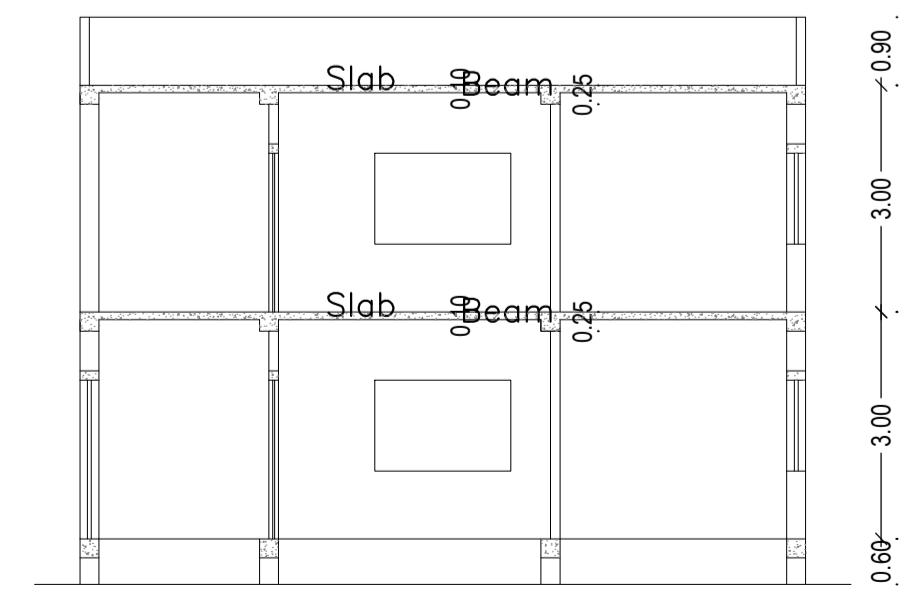
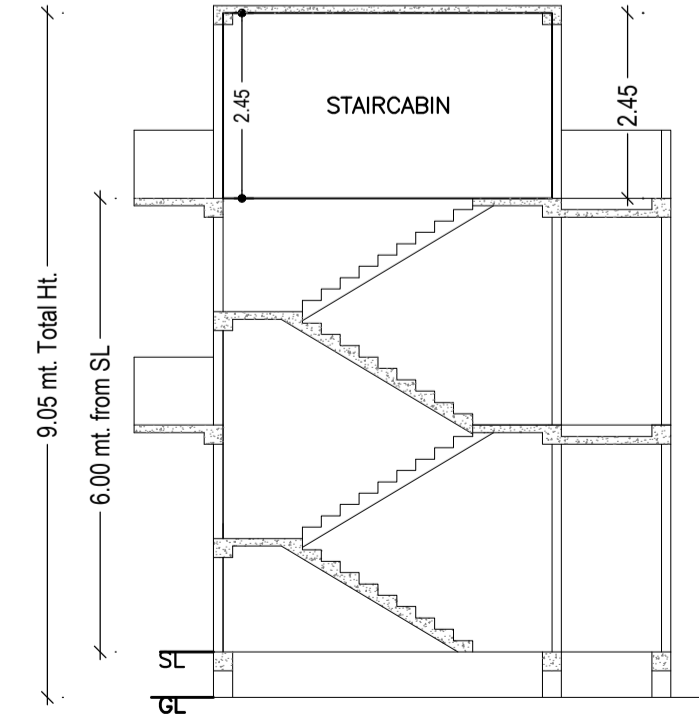

COLOR INDEX

PLOT BOUNDARY	Black
ABUTTING ROAD	Green
PROPOSED CONSTRUCTION	Red
COMMON PLOT	Yellow
ROAD WIDENING AREA	Blue
EXISTING (To be retained)	Light Blue
EXISTING (To be demolished)	Dark Blue

AREA STATEMENT LOHARDAGA NAGAR PARISHAD		VERSION NO.: 1.0.62
PROJECT DETAIL:		VERSION DATE: 16/10/2020
Region: JHARKHAND URBAN	Plot Use: Residential	
District: LOHARDAGA	Plot SubUse: Bungalow/ Dwelling / Non Apartment	
Authority: LOHARDAGA NAGAR PARISHAD	PlotNearby/ReligiousStructure: NA	
Inward No: LNP/BP/0020/W22/2022	Plot/SubPlot No: 520/462	
Application Type: General Proposal	North: Road Width - 3.65	
Project Type: Building Permission	South: Plot No. - 499	
Nature of Development: New	East: Plot No. - 520	
Location of Development Area: Old Area	West: Plot No. - 520	
AREA DETAILS:		SQ.MT.
AREA OF PLOT (Minimum)	(A)	400.98
Deduction for NetPlot Area		
Surrender Free of Cost		17.49
Total		17.49
NET AREA OF PLOT(Gross Plot Area - Deduction from Gross Plot Area)	(A-Deductions)	383.49
Deduction for Balance Plot Area(from Gross Plot Area)		
Surrender Free of Cost		17.49
Common Plot		41.85
Total		59.34
BALANCE AREA OF PLOT(Net Plot Area - Recreational/Amenity space)	(A-Deductions)	341.64
PLOT AREA FOR COVERAGE(Net Plot Area)	(A-Deductions)	383.49
Plot Area for FAR (Net Plot Area + RoadWidening Area)	(A-Deductions)	400.98
COVERAGE CHECK		
Permissible Coverage area (60.00 %)		230.09
Proposed Coverage Area (19.87 %)		76.19
Total Prop. Coverage Area (19.87 %)		76.19
Balance coverage area (40.13 %)		153.90
FAR CHECK		
Perm. FAR Area (1.50)		601.47
Total Perm. FAR area		601.47
Residential FAR		152.38
Proposed FAR Area		152.38
Total Proposed FAR Area		152.38
Consumed FAR (Factor)		0.38
Balance FAR Area		449.09
BUILT UP AREA CHECK		
Total Proposed BuiltUp Area		152.38
ARCHITECT (Regd)	Ataul Haque	
ENGINEER (Regd)		
SUPERVISOR (Regd)		
OWNER (Regd)	SHANTI BALA TIRKEY	
DEVELOPMENT AUTHORITY	LOCAL BODY	

LTP NAME AND SIGNATURE	STRUCTURAL ENG'S NAME AND SIGNATURE	BUILDER NAME AND SIGNATURE	DIGITAL SIGNATURE
Ataul Haque LNP/ENG/001/2021			