

Proposal Basic Information	
Proposal File No.	LNP/BP/0054/W13/2022
Owner Name	MD ANWAR ANSARI
Khata No	63/66
Plot No	348/349
Village Name	Nadia
Use	Residential
SubUse	Bungalow/ Dwelling / Non Apartment

BUILDING NAME	NAME	LENGTH	HEIGHT	NOS
ABC (123)	D	0.75	2.10	02
ABC (123)	D	0.96	2.10	02
ABC (123)	D	1.01	2.10	01
ABC (123)	D	1.05	2.10	05
ABC (123)	D	1.10	2.10	01

BUILDING NAME	NAME	LENGTH	HEIGHT	NOS
ABC (123)	V	0.60	1.20	02
ABC (123)	W	0.90	1.20	01
ABC (123)	W	1.20	1.20	04
ABC (123)	W	1.50	1.20	05

FLOOR	Name	UnitBUA Type	UnitBUA Area	Carpet Area	No. of Rooms	No. of Tenement
GROUND FLOOR PLAN	SPLIT SPLIT	FLAT	131.66	126.03	7	1
FIRST FLOOR PLAN	SPLIT SPLIT	FLAT	0.00	0.00	3	0
Total:	-	-	131.66	126.03	10	1

Floor Name	Building Name		Total	
	Proposed Built Up Area (Sq.mt.)	Proposed FAR Area (Sq.mt.)	Total Proposed Built Up Area (Sq.mt.)	Total FAR Area (Sq.mt.)
Ground Floor	83.01	83.01	83.01	83.01
First Floor	48.65	45.93	48.65	45.93
Terrace Floor	0.00	0.00	0.00	0.00
Total :	131.66	128.94	131.66	128.94

AREA STATEMENT		VERSION NO. : 1.0.64
LOHARDAGA NAGAR PARISHAD		VERSION DATE: 16/10/2020
PROJECT DETAIL:		
Region: JHARKHAND URBAN LOCAL BODIES	Plot Use: Residential	
District: LOHARDAGA	Plot SubUse: Bungalow/ Dwelling / Non Apartment	
Authority: LOHARDAGA NAGAR PARISHAD	PlotNearbyReligiousStructure: NA	
Inward_No: LNP/BP/0054/W13/2022	PlotSubPlot No: 348/349	
Application Type: General Proposal	North: Plot No. - 349	
Project Type: Building Permission	South: Plot No. - 348	
Nature of Development: New	East: Road Width - 3	
Location of Development Area: Old Area	West: Plot No. - 344	
AREA DETAILS:		SQ.MT.
AREA OF PLOT (Minimum)	(A)	809.21
Deduction for NetPlot Area		
Surrender Free of Cost		38.94
Total		38.94
NET AREA OF PLOT(Gross Plot Area - Deduction from Gross Plot area)	(A-Deductions)	770.27
Deduction for Balance Plot Area(from Gross Plot Area)		
Surrender Free of Cost		38.94
Common Plot		56.48
Total		95.42
BALANCE AREA OF PLOT(Net Plot Area - Recreational/Amenity space)	(A-Deductions)	713.79
PLOT AREA FOR COVERAGE(Net Plot Area)	(A-Deductions)	770.27
Plot Area for FAR (Net Plot Area + RoadWidening Area)	(A-Deductions)	809.21
COVERAGE CHECK		
Permissible Coverage area ( 60.00 % )		462.16
Proposed Coverage Area ( 10.78 % )		83.01
Total Prop. Coverage Area ( 10.78 % )		83.01
Balance coverage area ( 49.22 % )		379.15
FAR CHECK		
Perm. FAR Area ( 1.200 )		971.05
Total Perm. FAR area		971.05
Residential FAR area		128.94
Proposed FAR Area		128.94
Total Proposed FAR Area		128.94
Consumed FAR (Factor)		0.16
Balance FAR Area		842.11
BUILT UP AREA CHECK		
Total Proposed BuiltUp Area		131.66
ARCHITECT ( Regd )	Ataul Haque	
ENGINEER ( Regd )		
SUPERVISOR ( Regd )		
OWNER ( Regd )	MD ANWAR ANSARI	
DEVELOPMENT AUTHORITY		LOCAL BODY

Building Name	Building Use	Building SubUse	Building Structure
ABC (123)	Residential	Bungalow/ Dwelling / Non Apartment	Non-Highrise

FLOOR	SIZE	AREA	TOTAL AREA
FIRST FLOOR PLAN	1.20 X 4.54 X 1 X 1	5.45	5.45
Total	-	-	5.45

Building	No. of Same Bldg	Total Built Up Area (Sq.mt.)	Deductions (Area in Sq.mt.)	Proposed FAR Area (Sq.mt.)	Total FAR Area (Sq.mt.)	Total Consumed Additional FAR Area (Sq.mt.)	Trmt (No.)
ABC (123)	1	131.66	2.72	128.94	128.94	128.94	01
Grand Total :	1	131.66	2.72	128.94	128.94	128.94	01

Floor Name	Total Built Up Area (Sq.mt.)	Deductions (Area in Sq.mt.)	Proposed FAR Area (Sq.mt.)	Total FAR Area (Sq.mt.)	Total Consumed Additional FAR Area (Sq.mt.)	Trmt (No.)
Ground Floor	83.01	0.00	83.01	83.01	83.01	01
First Floor	48.65	2.72	45.93	45.93	45.93	00
Terrace Floor	0.00	0.00	0.00	0.00	0.00	00
Total :	131.66	2.72	128.94	128.94	128.94	01
Total Number of Same Buildings	1					
Total :	131.66	2.72	128.94	128.94	128.94	01

PLOT BOUNDARY	
ABUTTING ROAD	
PROPOSED CONSTRUCTION	
COMMON PLOT	
ROAD WIDENING AREA	
EXISTING (To be retained)	
EXISTING (To be demolished)	

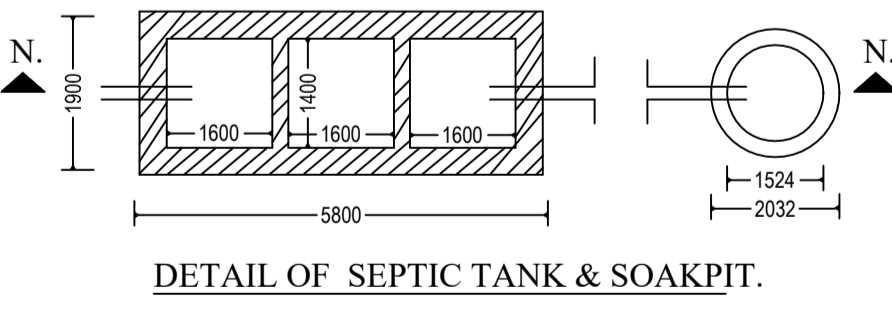
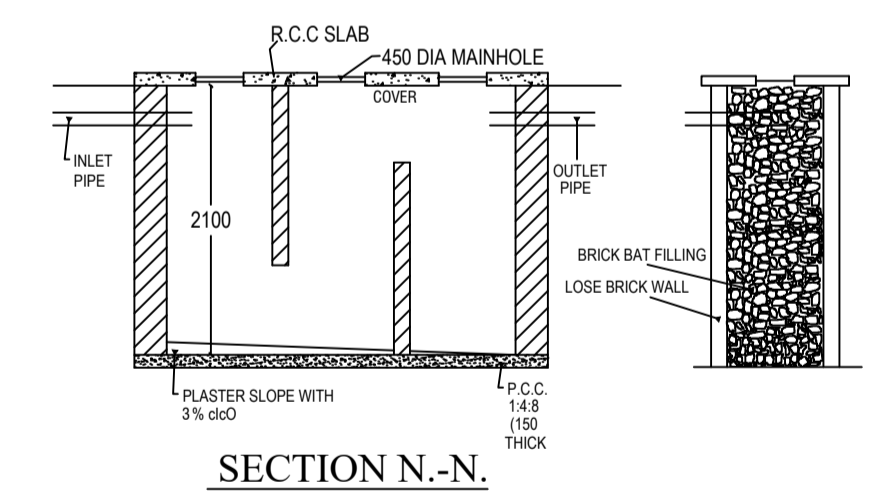
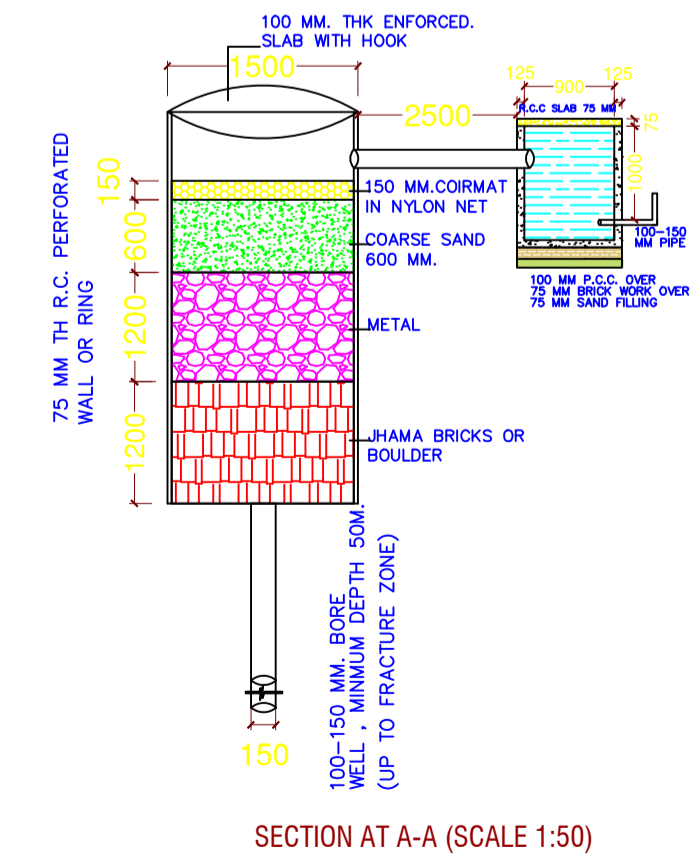
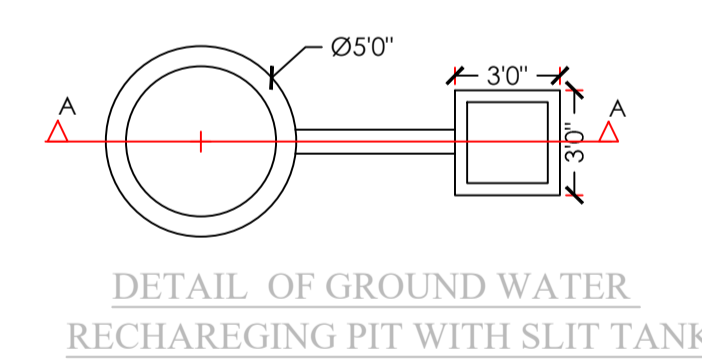
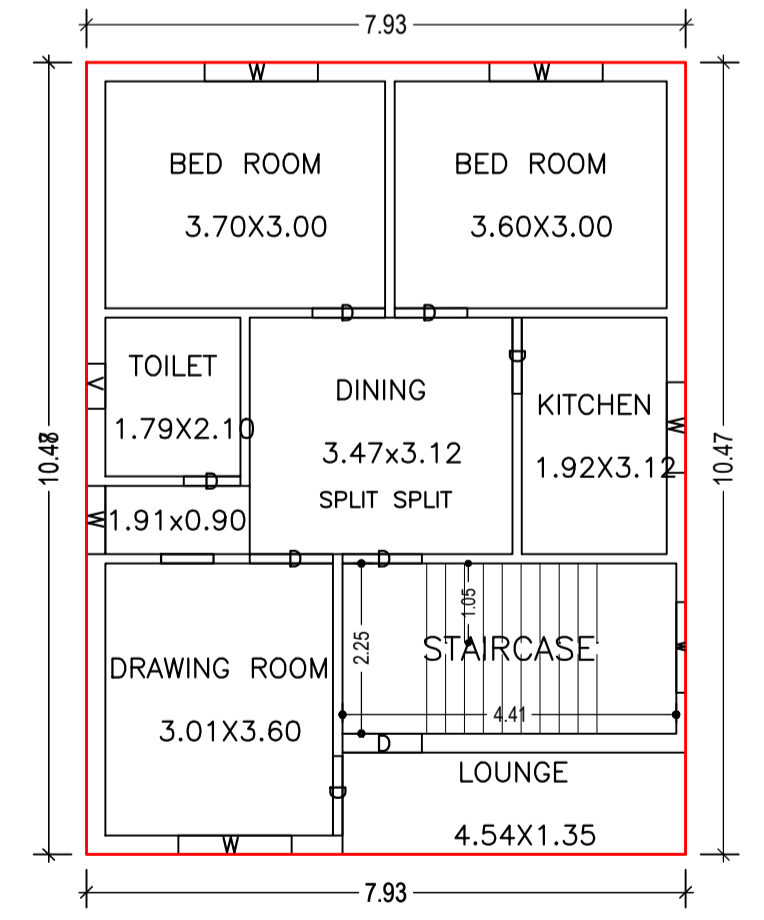

LTP NAME AND SIGNATURE	STRUCTURAL ENG'S NAME AND SIGNATURE	BUILDER NAME AND SIGNATURE	DIGITAL SIGNATURE
Ataul Haque LNP/ENG/001/2021			