

GROUND FLOOR PLAN
(Proposed)
(SCALE 1:100)

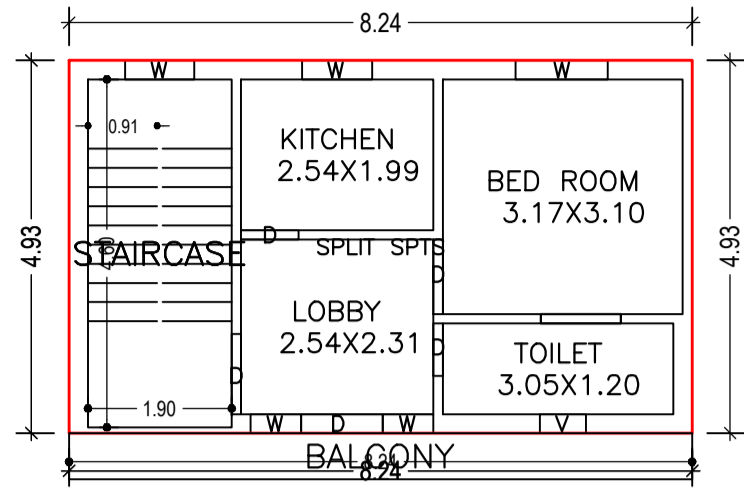

FIRST FLOOR PLAN
(Proposed)
(SCALE 1:100)

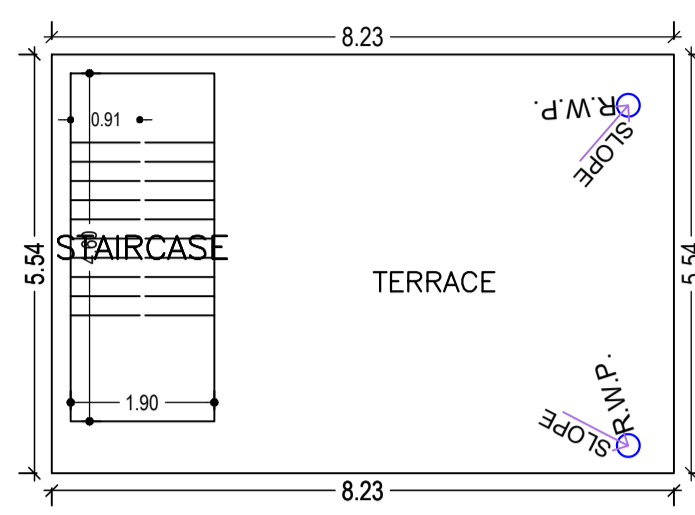

TERRACE FLOOR PLAN
(SCALE 1:100)

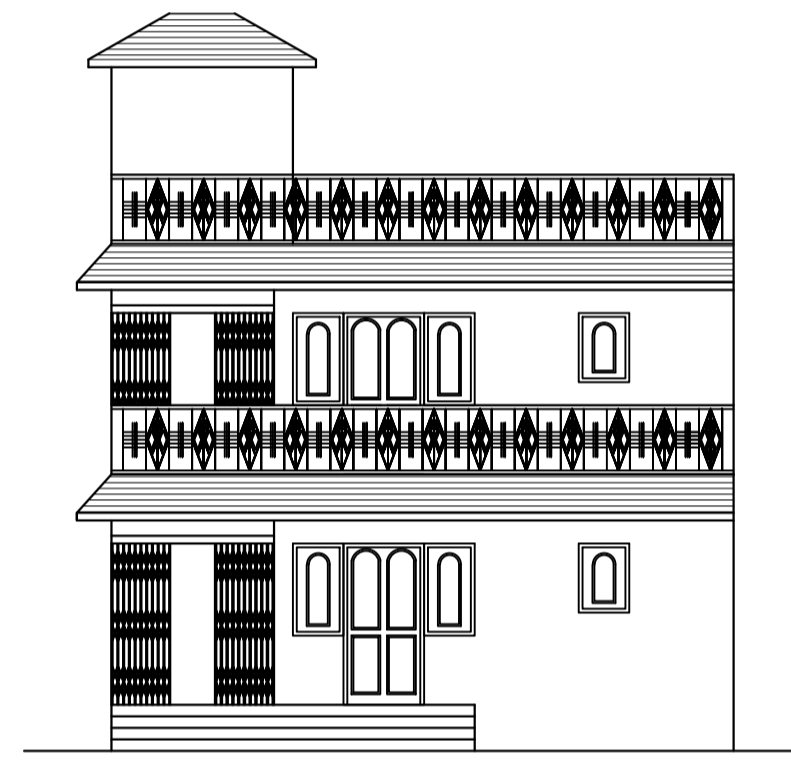

FRONT ELEVATION
SCALE :- 1"=100

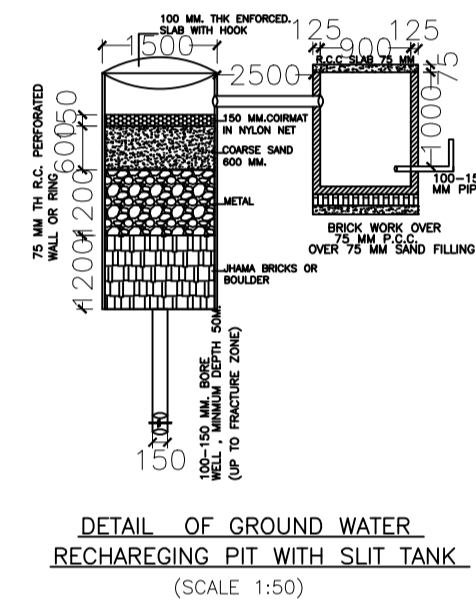

DETAIL OF GROUND WATER
RECHARGING PIT WITH SLIT TANK
(SCALE 1:50)

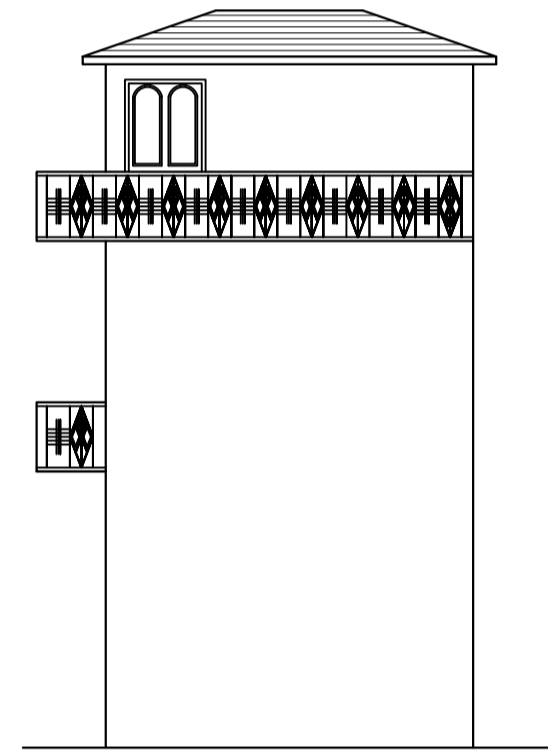

RIGHT SIDE ELEVATION
SCALE :- 1"=100

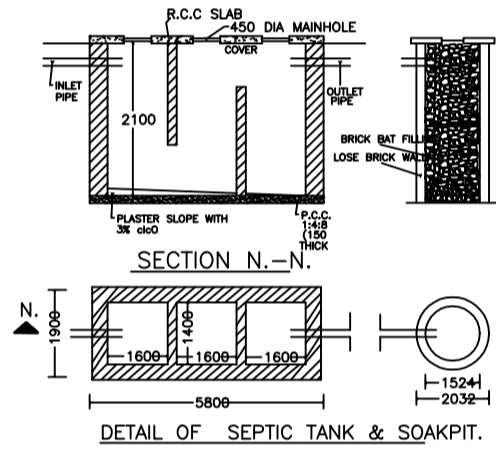

SECTION N-N
DETAIL OF SEPTIC TANK & SOA/PIT.

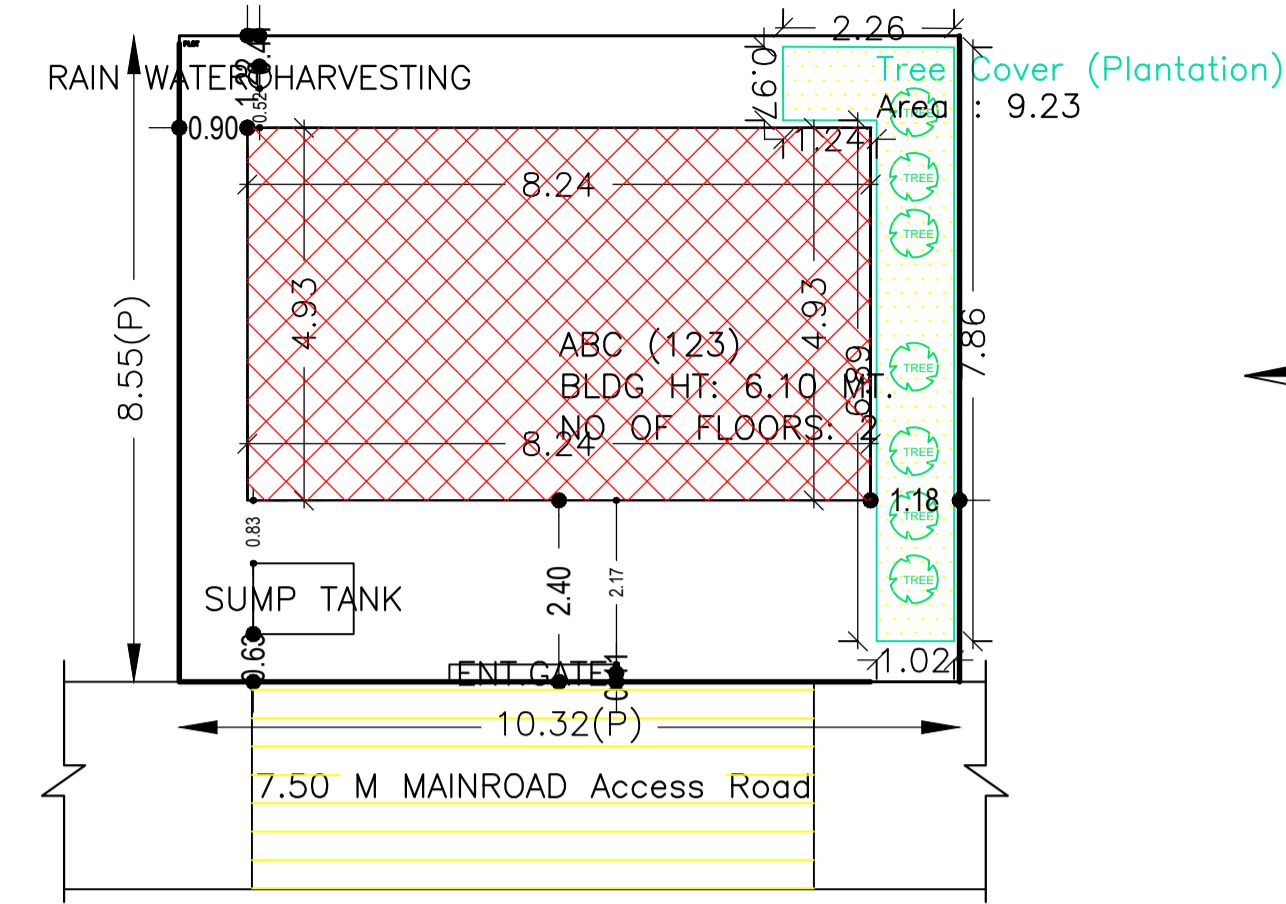

SITE PLAN
SCALE :- nts

SITE PLAN

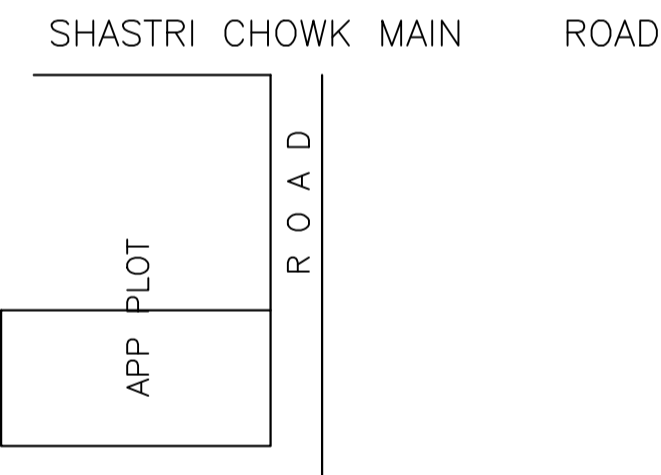

KEY PLAN
AS PER SITE

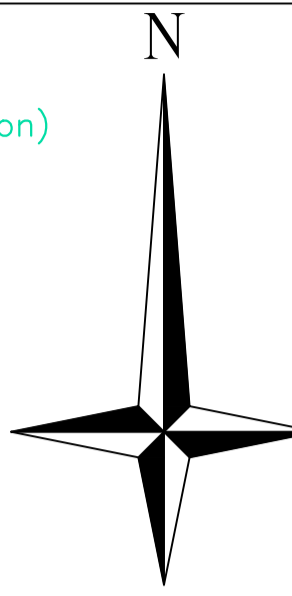

Proposal Basic Information	
Proposal File No.	LNP/BI/0032/W16/2023
Owner Name	VARUN KUMAR
Khata No.	-
Plot No.	M/S 1128
Village Name	Lohardaga
Use	Residential
SubUse	Bungalow/ Dwelling / Non Apartment

UnitBUA Table for Building :ABC (123)

FLOOR	Name	UnitBUA Type	UnitBUA Area	Carpet Area	No. of Rooms	No. of Tenement
GROUND FLOOR PLAN	SPLIT SPTS	FLAT	86.29	81.02	4	1
FIRST FLOOR PLAN	SPLIT SPTS	FLAT	0.00	0.00	4	0
Total:	-	-	86.29	81.02	8	1

SCHEDULE OF DOOR:

BUILDING NAME	NAME	LENGTH	HEIGHT	NOS
ABC (123)	D	0.69	2.10	02
ABC (123)	D	0.76	2.10	02
ABC (123)	D	0.98	2.10	02
ABC (123)	D	1.06	2.10	02
ABC (123)	D	1.08	2.10	02

SCHEDULE OF WINDOW/VENTILATION:

BUILDING NAME	NAME	LENGTH	HEIGHT	NOS
ABC (123)	V	0.61	1.20	02
ABC (123)	W	0.67	1.20	04
ABC (123)	W	0.91	1.20	02
ABC (123)	W	0.93	1.20	02
ABC (123)	W	1.22	1.20	02

Building :ABC (123)

Floor Name	Total Built Up Area (Sq.mt.)	Deductions (Area in Sq.mt.)	Proposed FAR Area (Sq.mt.)	Total FAR Area (Sq.mt.)	Total Consumed Additional FAR Area (Sq.mt.)	Tnmt (No.)
Ground Floor	40.63	0.00	40.63	40.63	40.63	01
First Floor	45.65	2.51	43.14	43.14	43.14	00
Terrace Floor	0.00	0.00	0.00	0.00	0.00	00
Total :	86.28	2.51	83.77	83.77	83.77	01
Total Number of Same Buildings	1					
Total :	86.28	2.51	83.77	83.77	83.77	01

Building USE/SUBUSE Details

Building Name	Building Use	Building SubUse	Building Structure
ABC (123)	Residential	Bungalow/ Dwelling / Non Apartment	Non-Highrise

FAR & Tenement Details (Table 4c-1)

Building	No. of Same Bldg	Total Built Up Area (Sq.mt.)	Deductions (Area in Sq.mt.)		Proposed FAR Area (Sq.mt.)	Total FAR Area (Sq.mt.)	Total Consumed Additional FAR Area (Sq.mt.)	Tnmt (No.)
			Balcony	Resi.				
ABC (123)	1	86.28	2.51	83.77	83.77	83.77	01	
Grand Total :	1	86.28	2.51	83.77	83.77	83.77	01	

Balcony Calculations Table

FLOOR	SIZE	AREA	TOTAL AREA
FIRST FLOOR PLAN	0.61 X 8.24 X 1 X 1	5.03	5.03
Total	-	-	5.03

Buildingwise Floor FAR Details

Floor Name	Building Name		Total	
	Proposed Built Up Area (Sq.mt.)	Proposed FAR Area (Sq.mt.)	Total Proposed Built Up Area (Sq.mt.)	Total FAR Area (Sq.mt.)
Ground Floor	40.63	40.63	40.63	40.63
First Floor	45.65	43.14	45.65	43.14
Terrace Floor	0.00	0.00	0.00	0.00
Total :	86.28	83.77	86.28	83.77

COLOR INDEX	
PLOT BOUNDARY	Black
ABUTTING ROAD	Green
PROPOSED CONSTRUCTION	Red
COMMON PLOT	Yellow
ROAD WIDENING AREA	Blue
EXISTING (To be retained)	Orange
EXISTING (To be demolished)	Light Blue

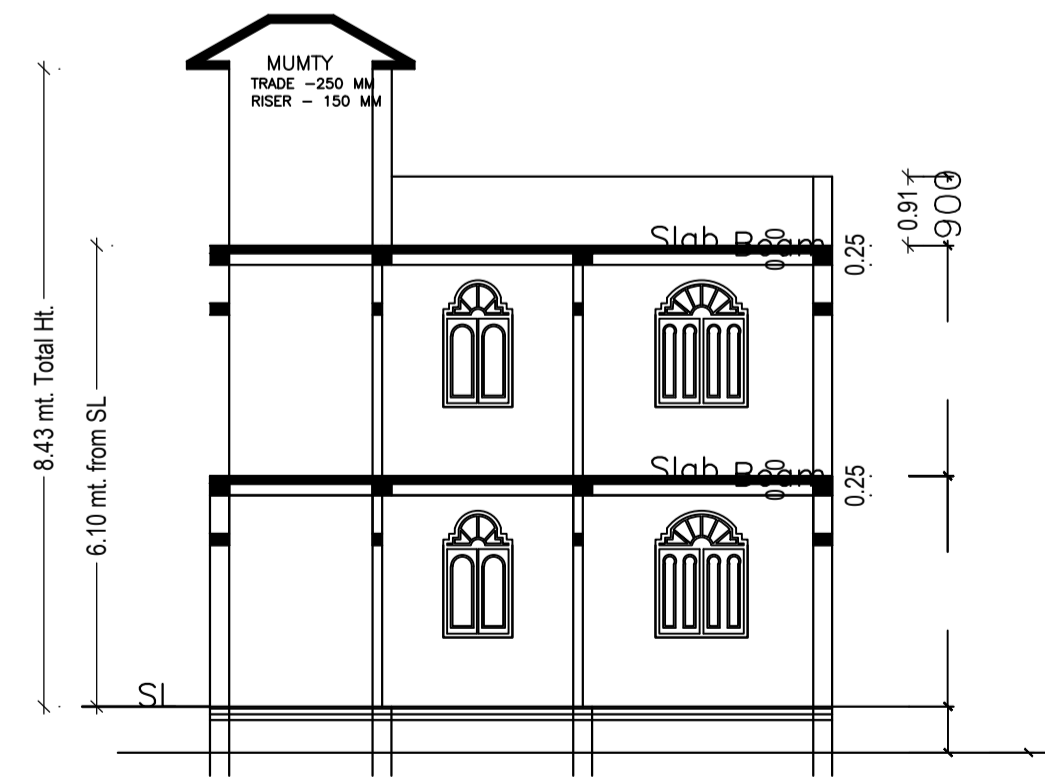

SECTION AT (X-X)
SCALE :- 1"=100

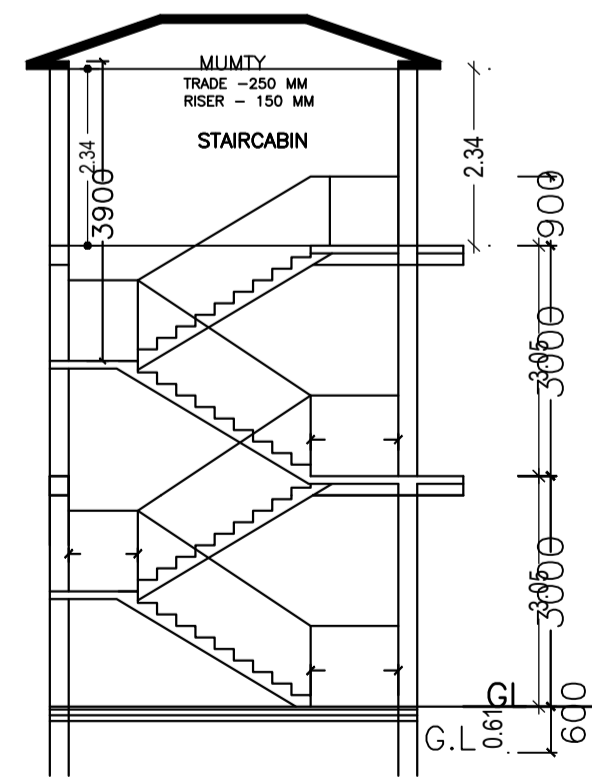

SECTION AT (Y-Y)
SCALE :- 1"=100

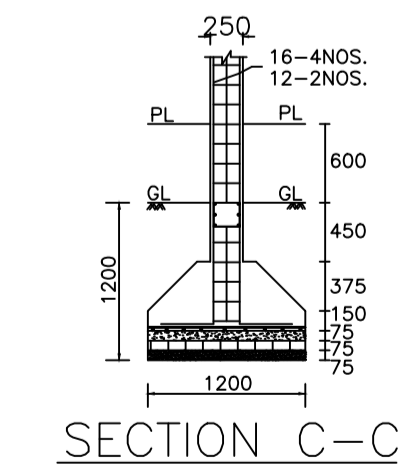

SECTION C-C

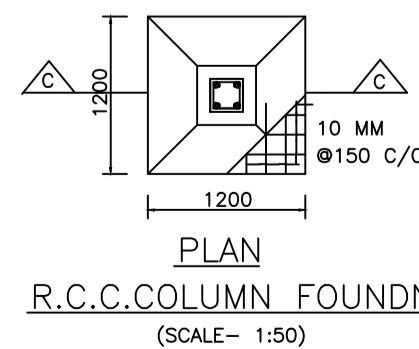

PLAN
R.C.C.COLUMN FOUNDN.
(SCALE :- 1:50)

LTP NAME AND SIGNATURE	STRUCTURAL ENG'S NAME AND SIGNATURE	BUILDER NAME AND SIGNATURE	DIGITAL SIGNATURE
SUNIL KUMAR LNP/ENG/0004/2017			