

Project Title :SUKHDEV BHAGAT

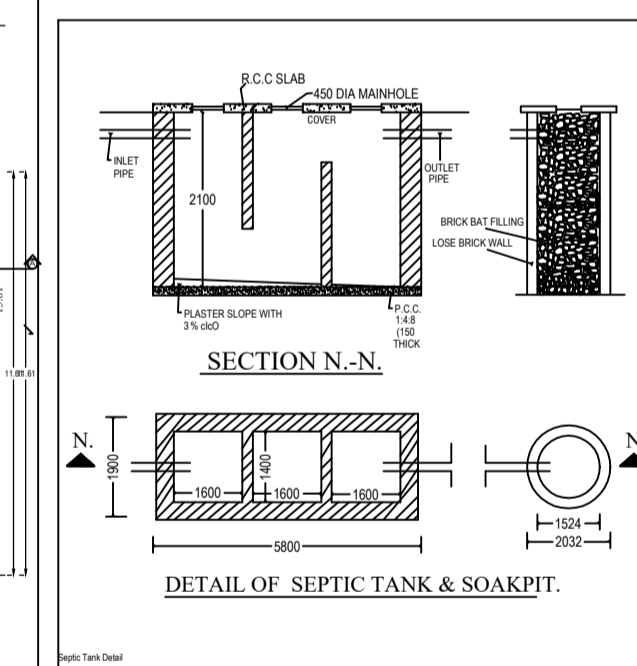
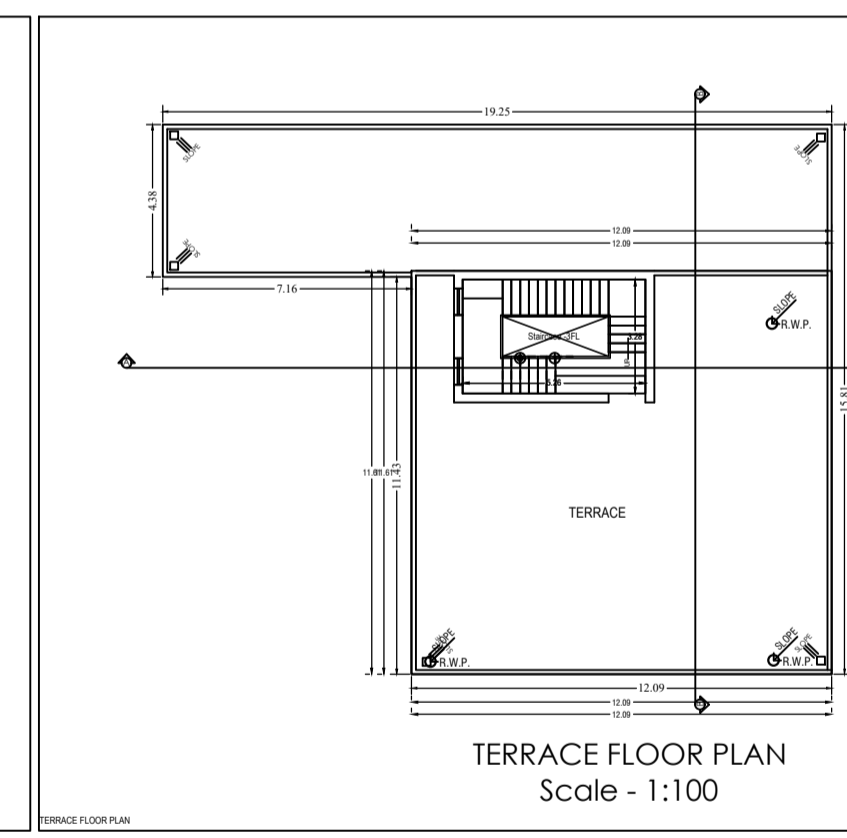
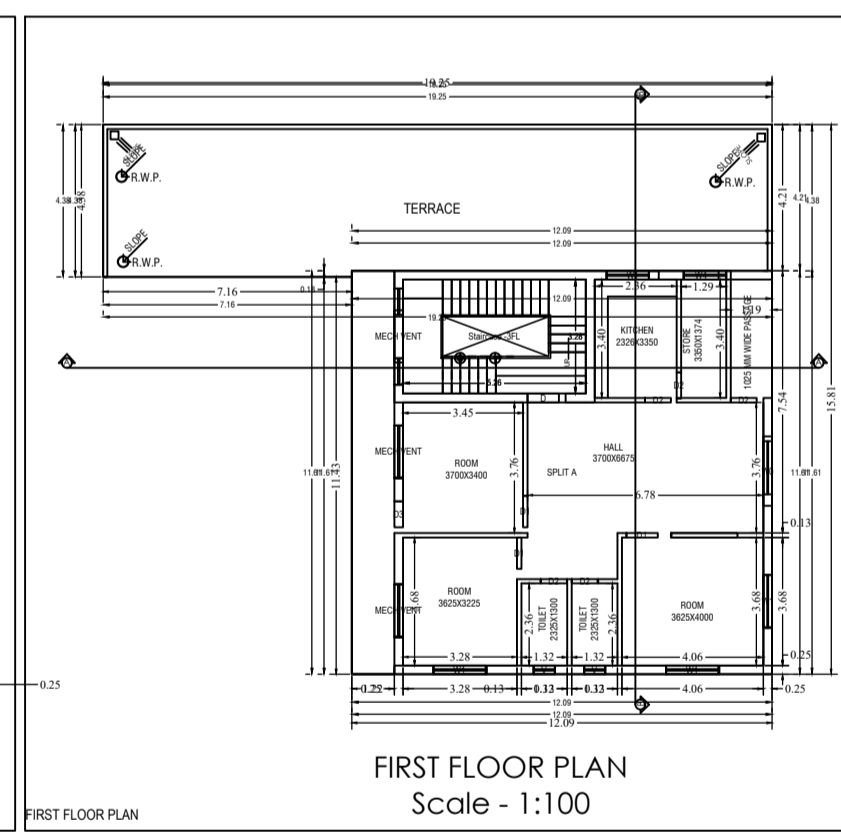
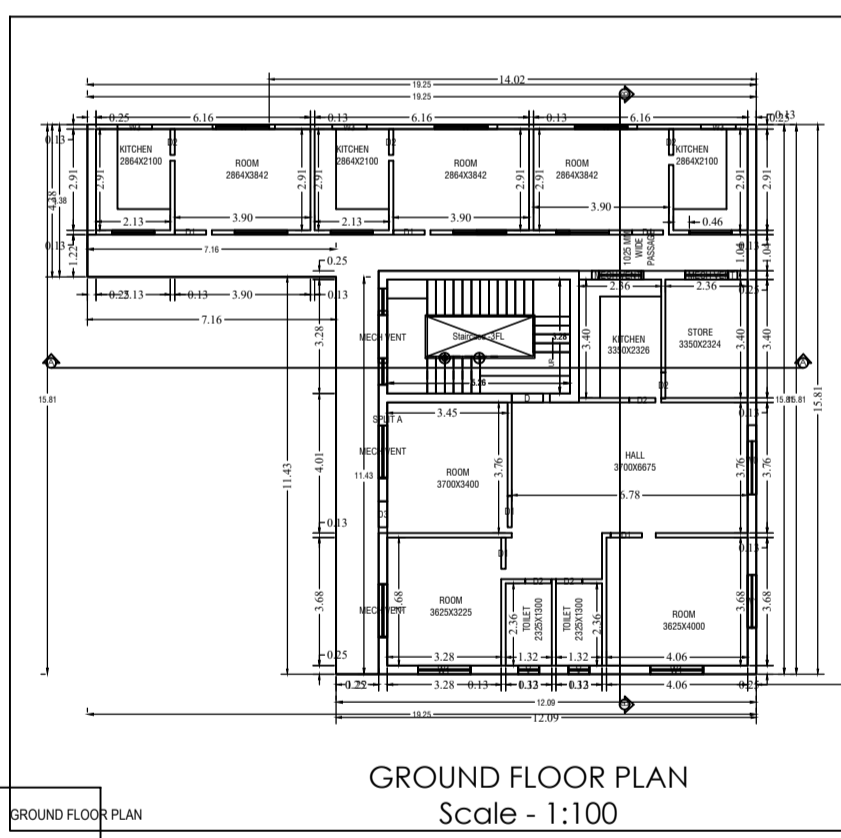
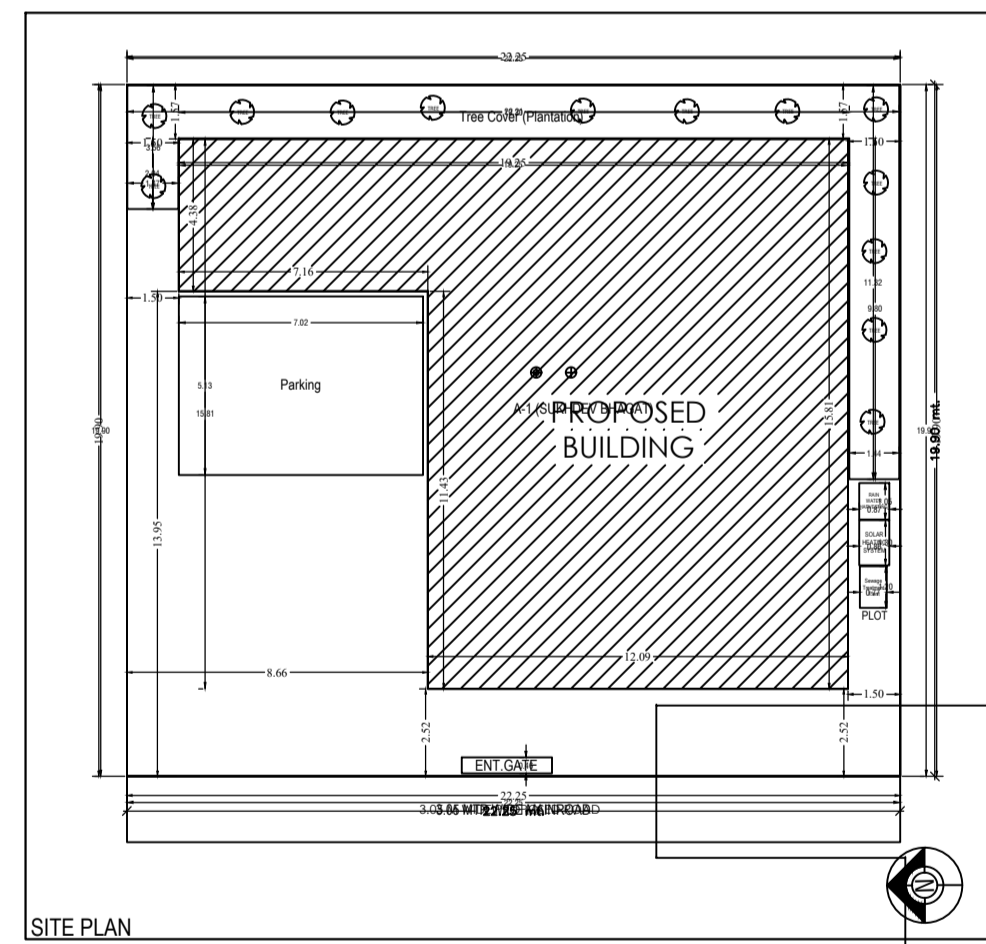
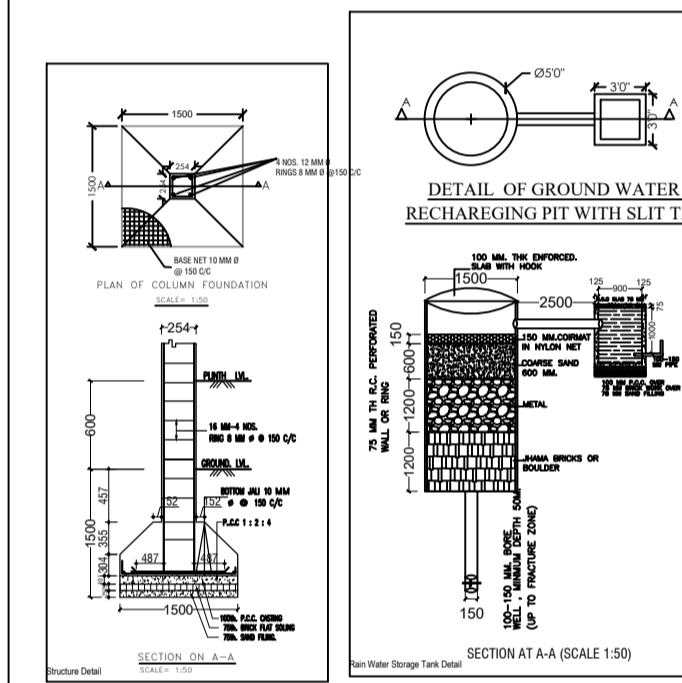
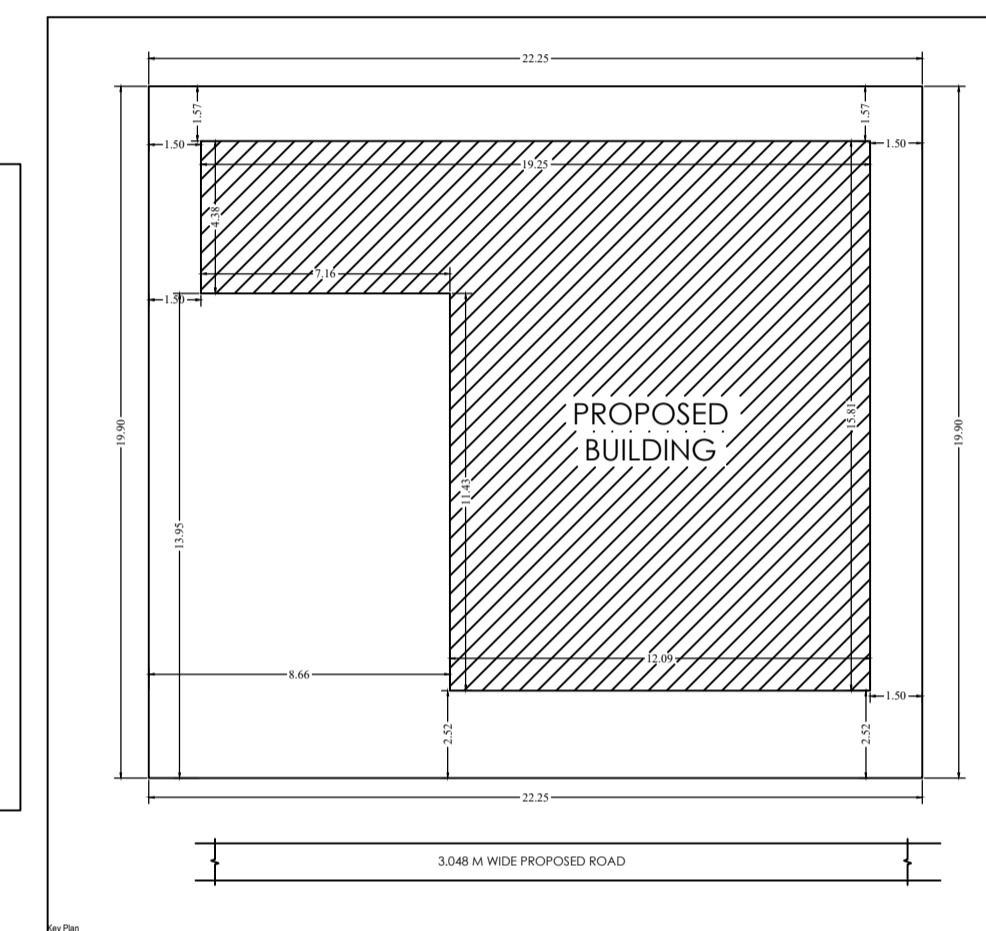
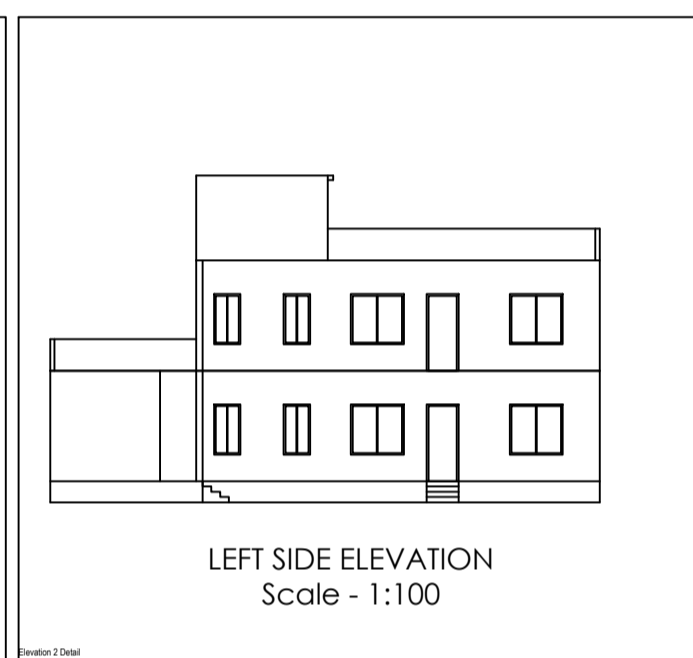
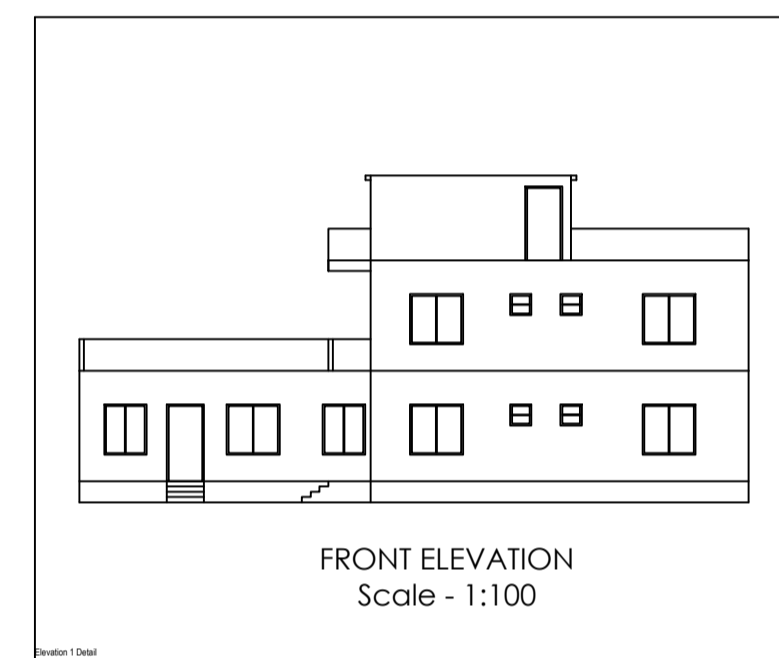
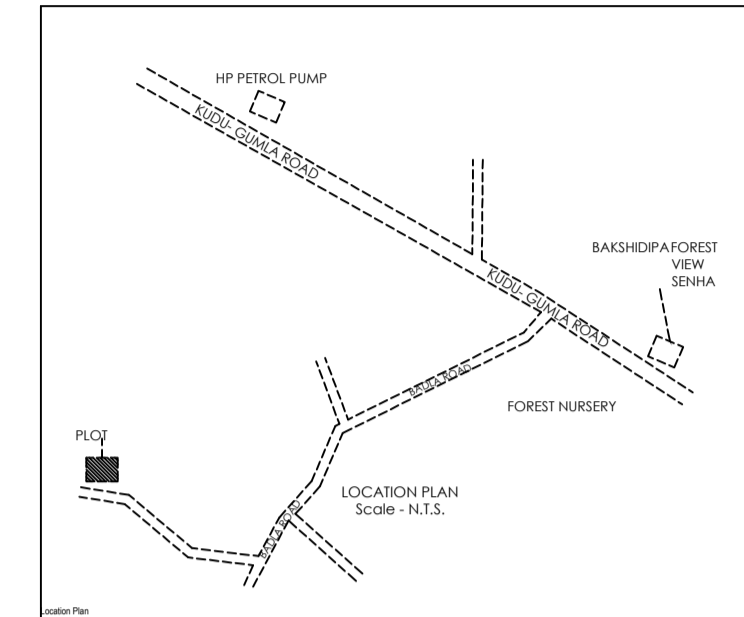
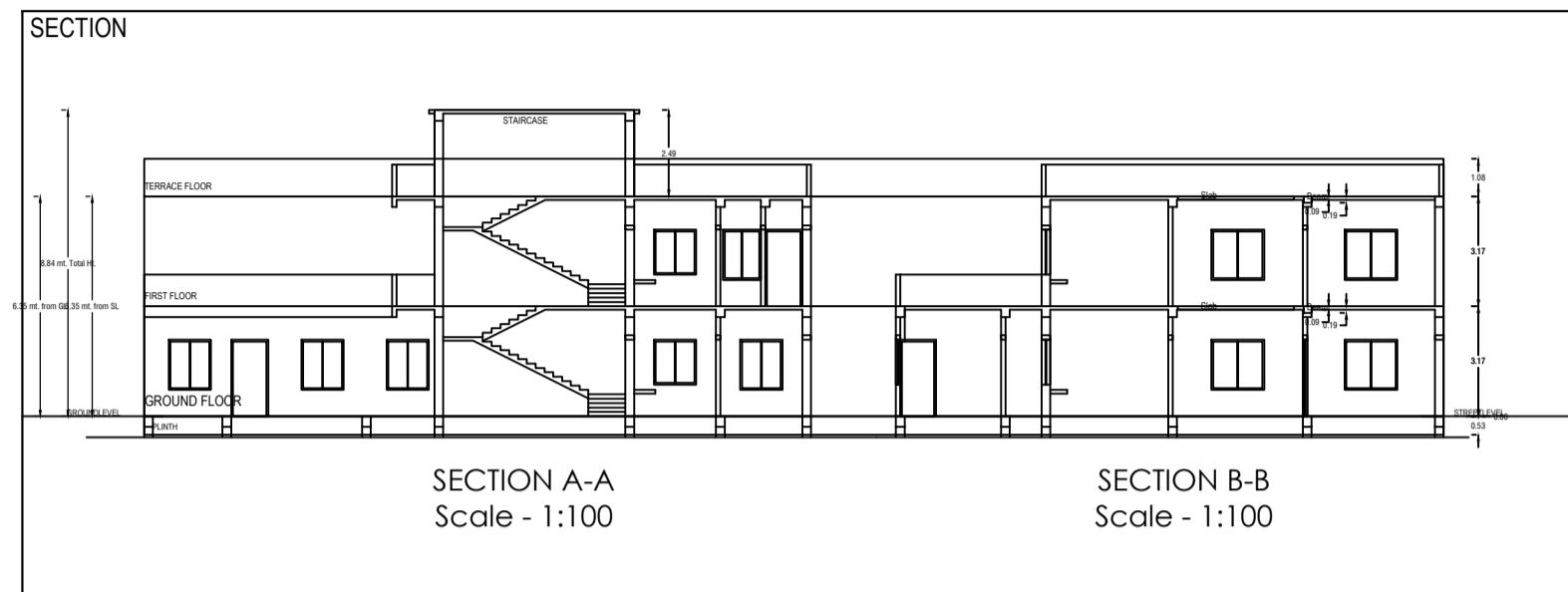

Building A (SUKHDEV BHAGAT)

Floor Name	Total Built up Area (Sq.m)	Proposed F.M. Area (Sq.m)	Total F.M. Area (Sq.m)	Area (Sq. Ft)
Ground Floor	222.7	222.7	222.7	2400
First Floor	222.7	222.7	222.7	2400
Terrace	111.35	111.35	111.35	1200
Total	556.75	556.75	556.75	6000

SCHEDULE OF JOINERY

Item Name	Unit	Quantity	Rate	Amount	MCQ
WOOD	sqm	100.00	4000.00	400000.00	4000
ALUMINIUM	sqm	100.00	2000.00	200000.00	2000
GLASS	sqm	100.00	1000.00	100000.00	1000
STEEL	kg	1000.00	100.00	100000.00	1000
CEMENT	kg	1000.00	100.00	100000.00	1000
BRICK	kg	1000.00	100.00	100000.00	1000
ROOFING	sqm	100.00	1000.00	100000.00	1000
PAINT	kg	1000.00	100.00	100000.00	1000
WATERPROOFING	sqm	100.00	1000.00	100000.00	1000
PLASTER	sqm	100.00	1000.00	100000.00	1000
CONCRETE	cu.m	100.00	1000.00	100000.00	1000
IRON	kg	1000.00	100.00	100000.00	1000
WIRE	kg	1000.00	100.00	100000.00	1000
PIPE	kg	1000.00	100.00	100000.00	1000
ROOFING	sqm	100.00	1000.00	100000.00	1000
PAINT	kg	1000.00	100.00	100000.00	1000
WATERPROOFING	sqm	100.00	1000.00	100000.00	1000
PLASTER	sqm	100.00	1000.00	100000.00	1000
CONCRETE	cu.m	100.00	1000.00	100000.00	1000
IRON	kg	1000.00	100.00	100000.00	1000
WIRE	kg	1000.00	100.00	100000.00	1000
PIPE	kg	1000.00	100.00	100000.00	1000

UNBUILT Table for Building A (SUKHDEV BHAGAT)

Item Name	Unit	Quantity	Rate	Amount	MCQ
WOOD	sqm	100.00	4000.00	400000.00	4000
ALUMINIUM	sqm	100.00	2000.00	200000.00	2000
GLASS	sqm	100.00	1000.00	100000.00	1000
STEEL	kg	1000.00	100.00	100000.00	1000
CEMENT	kg	1000.00	100.00	100000.00	1000
BRICK	kg	1000.00	100.00	100000.00	1000
ROOFING	sqm	100.00	1000.00	100000.00	1000
PAINT	kg	1000.00	100.00	100000.00	1000
WATERPROOFING	sqm	100.00	1000.00	100000.00	1000
PLASTER	sqm	100.00	1000.00	100000.00	1000
CONCRETE	cu.m	100.00	1000.00	100000.00	1000
IRON	kg	1000.00	100.00	100000.00	1000
WIRE	kg	1000.00	100.00	100000.00	1000
PIPE	kg	1000.00	100.00	100000.00	1000

Sl. No.	Particulars	Quantity	Rate	Amount
1
2
3
4
5
6
7
8
9
10
11
12
13
14
15
16
17
18
19
20
21
22
23
24
25
26
27
28
29
30
31
32
33
34
35
36
37
38
39
40
41
42
43
44
45
46
47
48
49
50
51
52
53
54
55
56
57
58
59
60
61
62
63
64
65
66
67
68
69
70
71
72
73
74
75
76
77
78
79
80
81
82
83
84
85
86
87
88
89
90
91
92
93
94
95
96
97
98
99
100