

Project Title : SUKHDEV BHAGAT

Proposal Basic Information

Proposal File No.	LNP/BP/0036/W21/2023
Owner Name	SUKHDEV BHAGAT
Khata No	335,369
Plot No	2070
Village Name	Lohardaga
Use	Residential
SubUse	Bungalow/ Dwelling / Non Apartment



**SCHEDULE OF DOOR:**

BUILDING NAME	NAME	LENGTH	HEIGHT	NOS
A (SUKHDEV BHAGAT)	D2	0.75	2.13	12
A (SUKHDEV BHAGAT)	D3	0.75	2.13	02
A (SUKHDEV BHAGAT)	D1	0.90	2.13	09
A (SUKHDEV BHAGAT)	D	0.50	2.13	02

**SCHEDULE OF WINDOW/VENTILATION:**

BUILDING NAME	NAME	LENGTH	HEIGHT	NOS
A (SUKHDEV BHAGAT)	V	0.60	2.70	04
A (SUKHDEV BHAGAT)	W4	1.00	2.70	01
A (SUKHDEV BHAGAT)	W3	1.00	2.70	03
A (SUKHDEV BHAGAT)	W1	1.50	2.70	07
A (SUKHDEV BHAGAT)	MECH VENT	1.50	2.70	08
A (SUKHDEV BHAGAT)	W	1.80	2.70	03
A (SUKHDEV BHAGAT)	W0	2.00	2.70	02

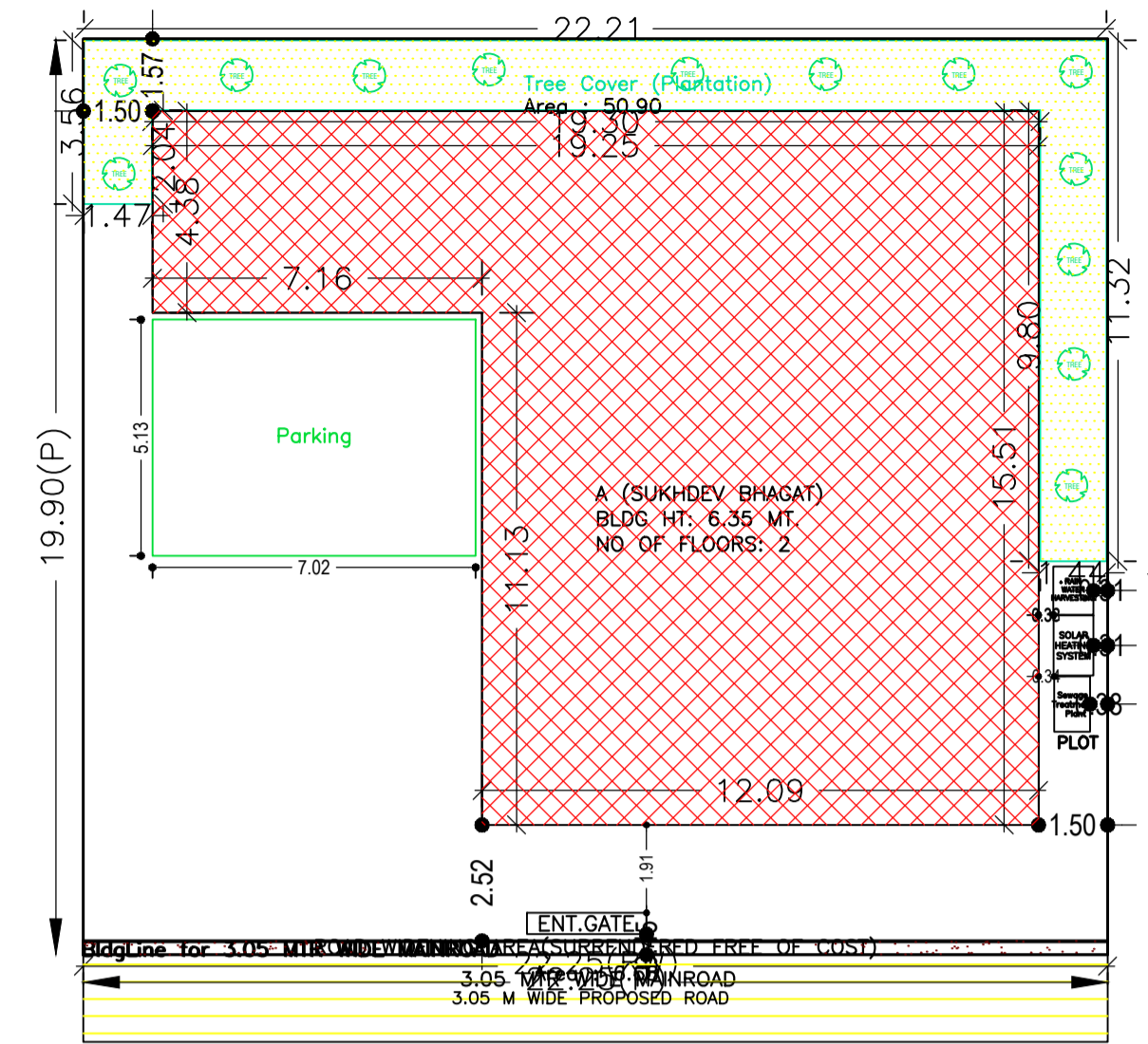
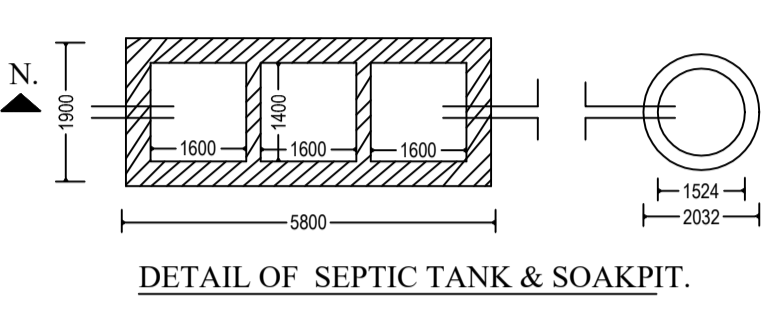
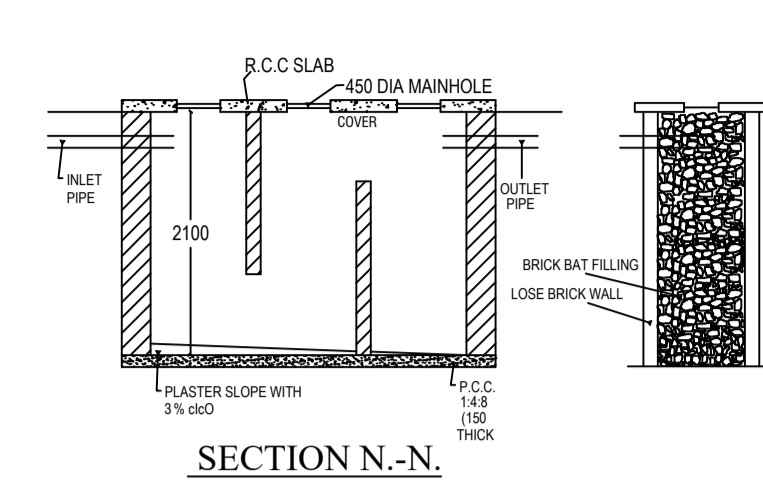

SITE PLAN

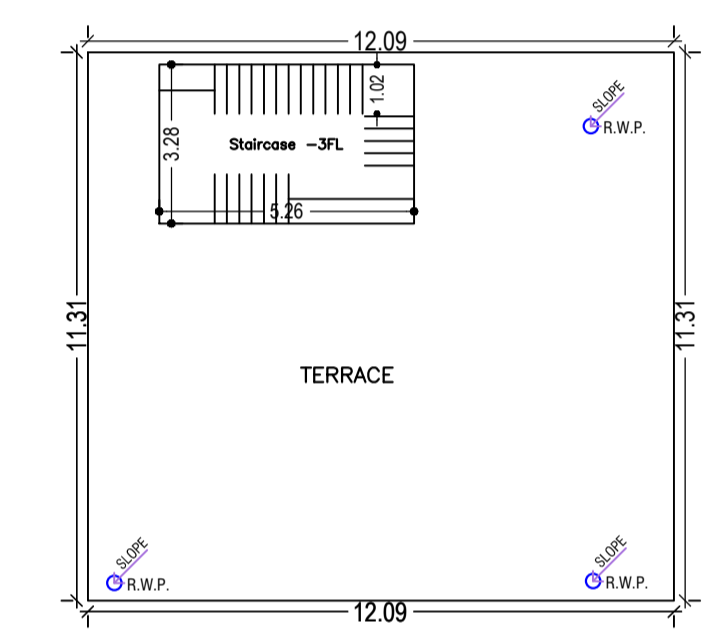

TERRACE FLOOR PLAN (SCALE 1:100)

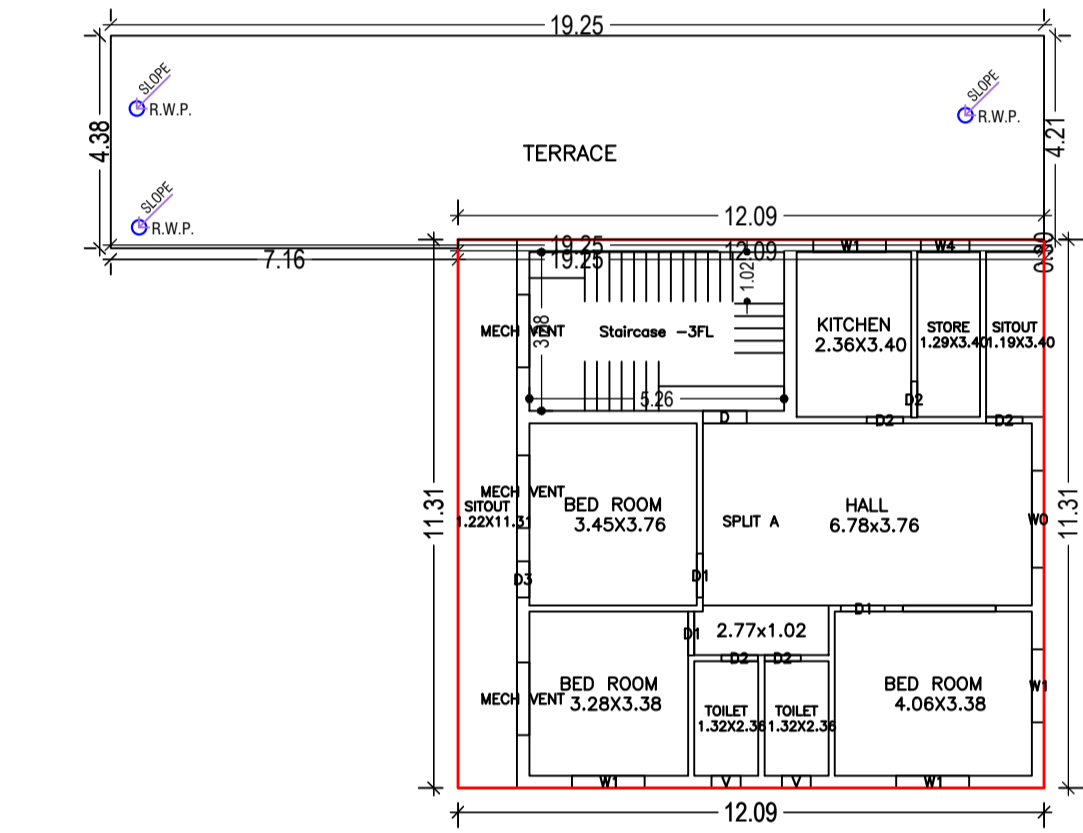

FIRST FLOOR PLAN (SCALE 1:100)

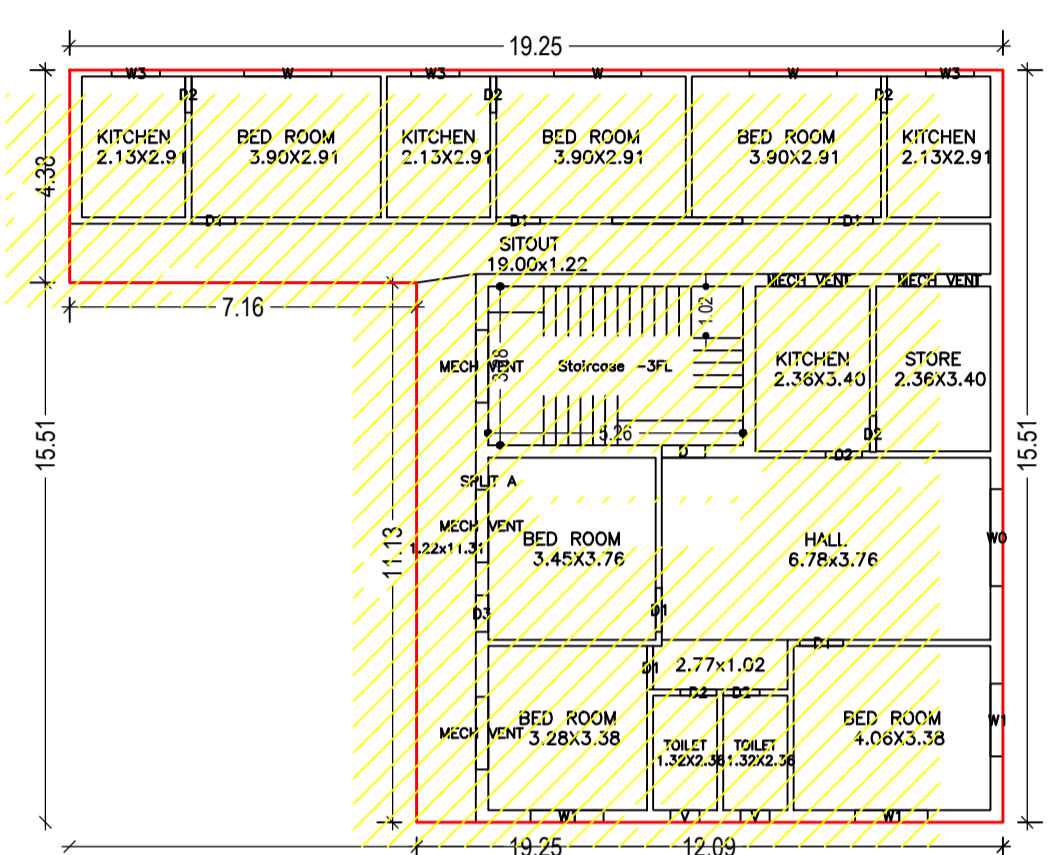

GROUND FLOOR PLAN (Proposed) (SCALE 1:100)

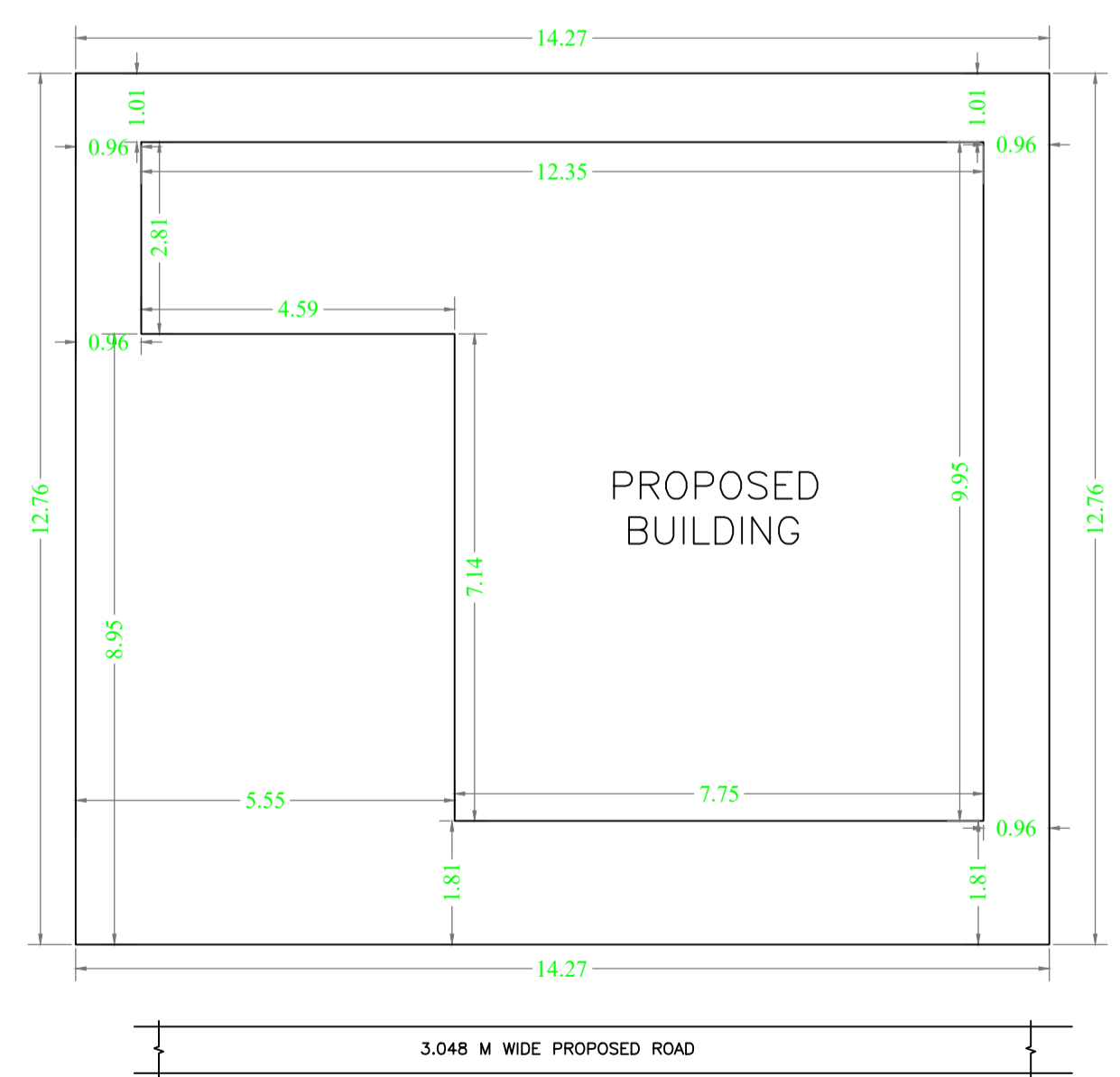

PROPOSED BUILDING

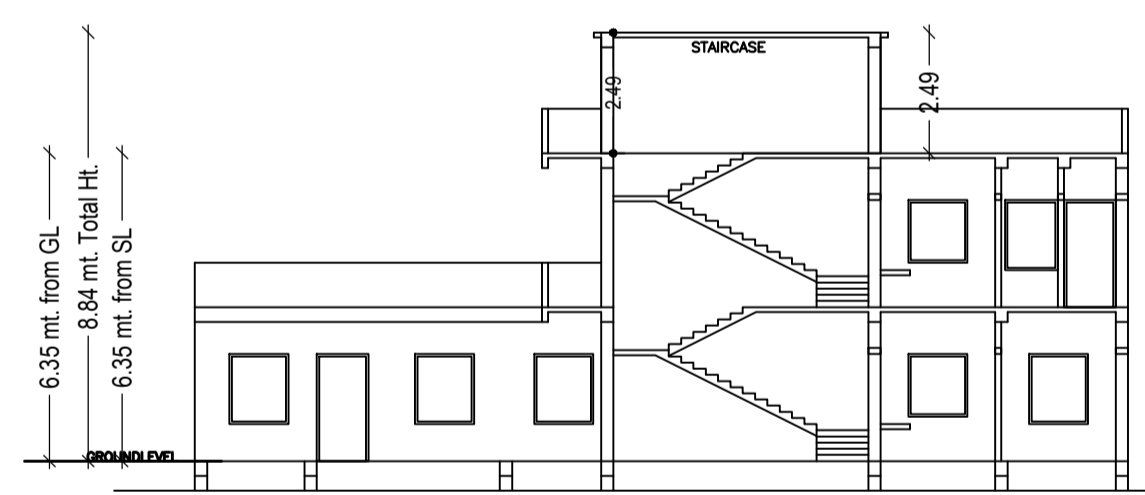

SECTION A-A Scale - 1:100

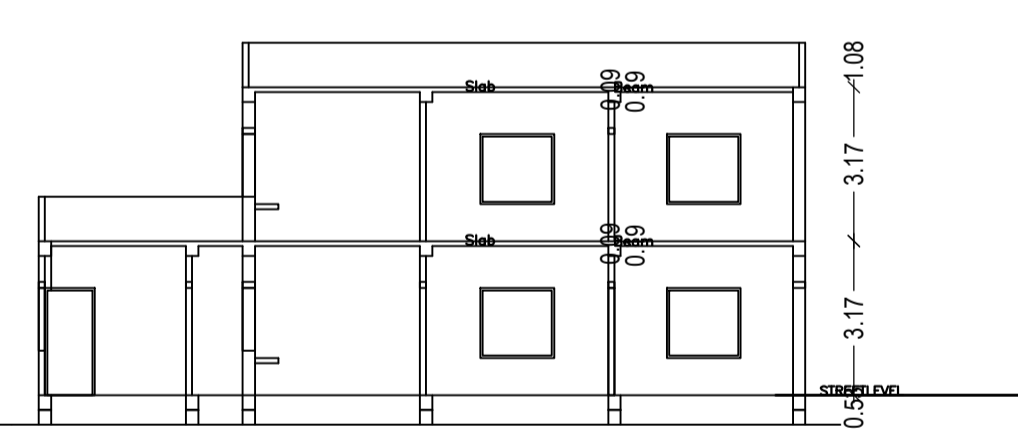

SECTION B-B Scale - 1:100

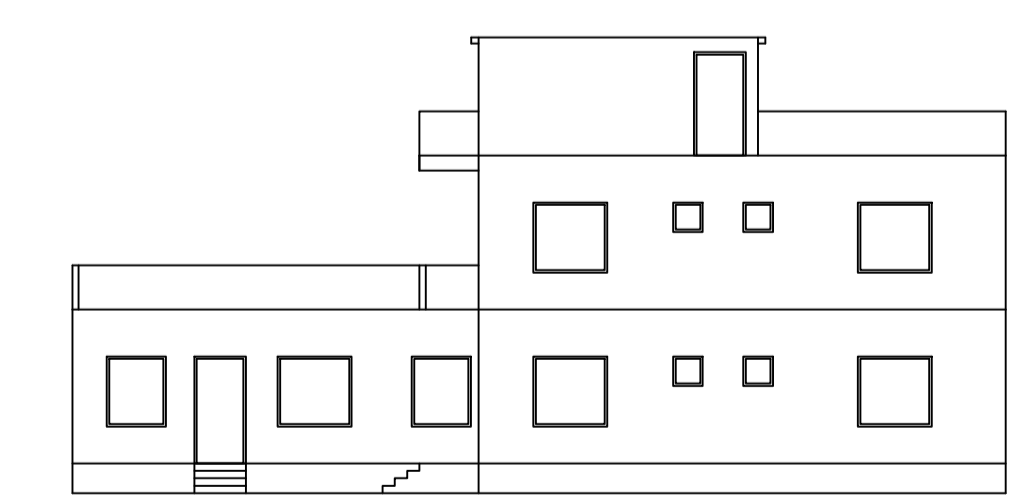

FRONT ELEVATION Scale - 1:100

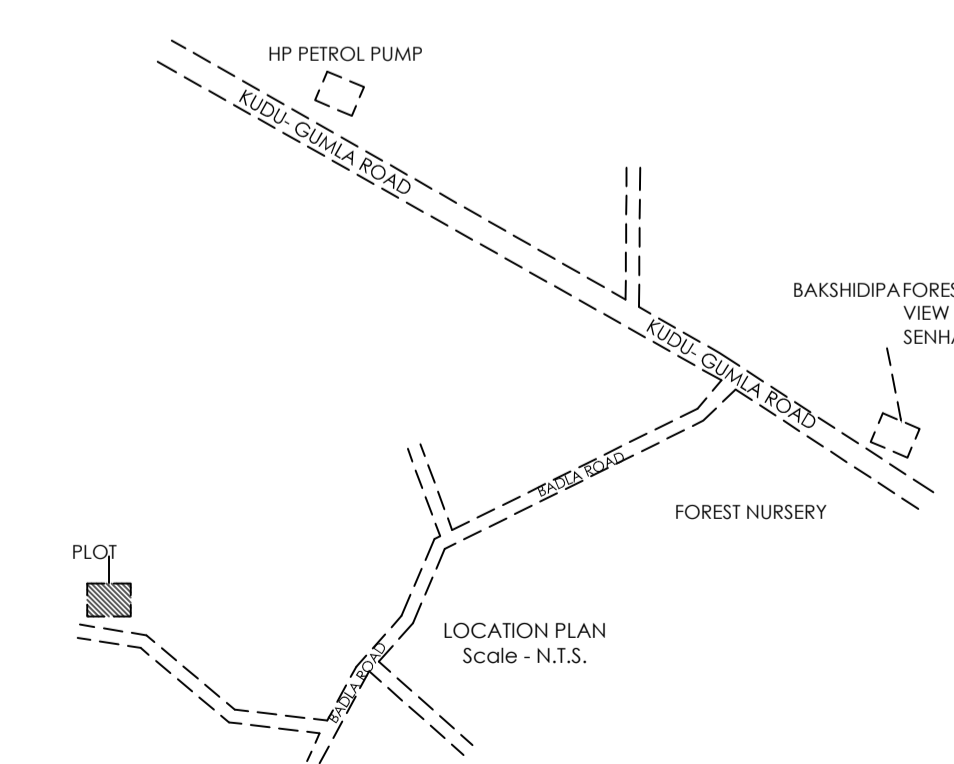

LOCATION PLAN Scale - N.T.S.

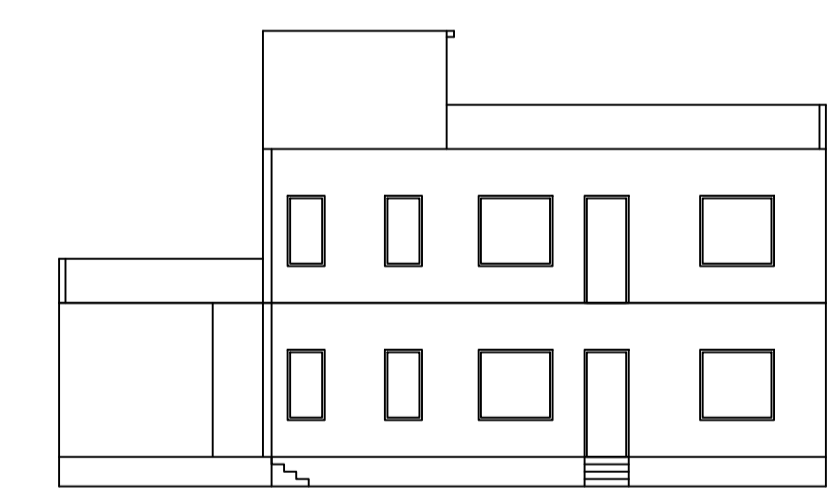

LEFT SIDE ELEVATION Scale - 1:100

Building USE/SUBUSE Details

Building Name	Building Use	Building SubUse	Building Structure
A (SUKHDEV BHAGAT)	Residential	Bungalow/ Dwelling / Non Apartment	Non-Highrise

**COLOR INDEX**

PLOT BOUNDARY	Black
ABUTTING ROAD	Red
PROPOSED CONSTRUCTION	Green
COMMON PLOT	Yellow
ROAD WIDENING AREA	Blue
EXISTING (To be retained)	Light Blue
EXISTING (To be demolished)	Light Yellow

UnitBUA Table for Building :A (SUKHDEV BHAGAT)

FLOOR	Name	UnitBUA Type	UnitBUA Area	Carpet Area	No. of Rooms	No. of Tenement
GROUND FLOOR PLAN	SPLIT A	FLAT	294.41	293.83	15	1
FIRST FLOOR PLAN	SPLIT A	FLAT	0.00	0.00	10	0
Total	-	-	294.41	293.83	25	1

Building :A (SUKHDEV BHAGAT)

Floor Name	Total Built Up Area (Sq.mt.)	Proposed FAR Area (Sq.mt.)	Total FAR Area (Sq.mt.)	Total Consumed Additional FAR Area (Sq.mt.)	Trmt (No.)
Ground Floor	218.94	218.94	218.94	218.94	01
First Floor	136.72	136.72	136.72	136.72	00
Terrace Floor	0.00	0.00	0.00	0.00	00
Total	355.66	355.66	355.66	355.66	01
Total Number of Same Buildings	1				
Total:	355.66	355.66	355.66	355.66	01

FAR & Tenement Details (Table 4c-1)

Building	No. of Same Bldg	Total Built Up Area (Sq.mt.)	Proposed FAR Area (Sq.mt.)	Total FAR Area (Sq.mt.)	Total Consumed Additional FAR Area (Sq.mt.)	Trmt (No.)
A (SUKHDEV BHAGAT)	1	355.66	355.66	355.66	355.66	01
Grand Total:	1	355.66	355.66	355.66	355.66	01

Buildingwise Floor FAR Details

Floor Name	Building Name A (SUKHDEV BHAGAT)		Total	
	Proposed Built Up Area (Sq.mt.)	Proposed FAR Area (Sq.mt.)	Total Proposed Built Up Area (Sq.mt.)	Total FAR Area (Sq.mt.)
Ground Floor	218.94	218.94	218.94	218.94
First Floor	136.72	136.72	136.72	136.72
Terrace Floor	0.00	0.00	0.00	0.00
Total:	355.66	355.66	355.66	355.66

**AREA STATEMENT**  
LOHARDAGA NAGAR PARISHAD  
VERSION NO.: 1.0.68  
VERSION DATE: 16/10/2020

**PROJECT DETAIL:**  
Region: JHARKHAND URBAN LOCAL BODIES  
District: LOHARDAGA  
Authority: LOHARDAGA NAGAR PARISHAD  
Inward No: LNP/BP/0036/W21/2023  
Application Type: General Proposal  
Project Type: Building Permission  
Nature of Development: New  
Location of Development Area: Old Area

Plot Use: Residential  
Plot SubUse: Bungalow/ Dwelling / Non Apartment  
PlotNearbyReligiousStructure: NA  
North: Plot No. - 2070  
South: Plot No. - 2070  
East: Road Width - 3.05 MTR WIDE MAIN ROAD  
West: Plot No. - 2070

**AREA DETAILS:**

AREA OF PLOT (Minimum)	(A)	SQ.MT.
Deduction for NetPlot Area		442.83
Surrender Free of Cost		6.68
Total		6.68
NET AREA OF PLOT(Gross Plot Area - Deduction from Gross Plot area)	(A-Deductions)	436.15
Deduction for Balance Plot Area(from Gross Plot Area)		6.68
Surrender Free of Cost		50.90
Total		57.58
BALANCE AREA OF PLOT(Net Plot Area - Recreational/Amenity space)	(A-Deductions)	385.25
PLOT AREA FOR COVERAGE(Net Plot Area)	(A-Deductions)	436.15
Plot Area for FAR (Net Plot Area + RoadWidening Area)	(A-Deductions)	442.83
<b>COVERAGE CHECK</b>		
Permissible Coverage area ( 60.00 % )		261.69
Proposed Coverage Area ( 50.20 % )		218.94
Total Prop. Coverage Area ( 50.2 % )		218.94
Balance coverage area ( 9.80 % )		42.75
<b>FAR CHECK</b>		
Perm. FAR Area ( 1.200 )		531.40
Total Perm. FAR area		531.40
Residential FAR		355.66
Proposed FAR Area		355.66
Total Proposed FAR Area		355.66
Consumed FAR (Factor)		0.80
Balance FAR Area		175.74
<b>BUILT UP AREA CHECK</b>		
Total Proposed BuiltUp Area		355.66
ARCHITECT (Regd)		ASHWINI KUMAR SAHU
ENGINEER (Regd)		
SUPERVISOR (Regd)		
OWNER (Regd)		SUKHDEV BHAGAT
DEVELOPMENT AUTHORITY		LOCAL BODY

LTP NAME AND SIGNATURE	STRUCTURAL ENG'S NAME AND SIGNATURE	BUILDER NAME AND SIGNATURE	DIGITAL SIGNATURE
ASHWINI KUMAR SAHU LNP/ENG/0005/2017			