

FRONT ELEVATION
Scale - 1:100

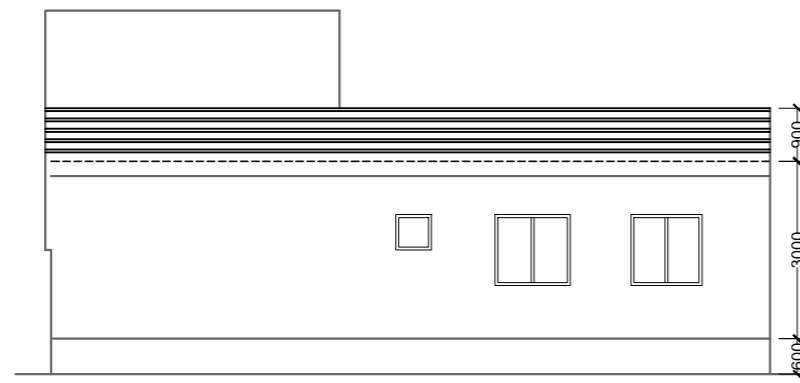

RIGHT SIDE ELEVATION
Scale - 1:100

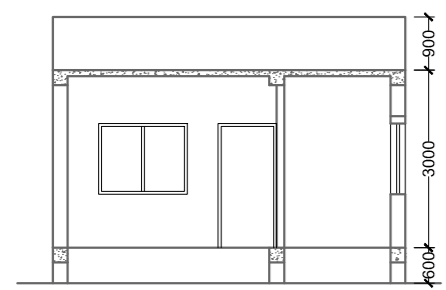

SECTION A-A
Scale - 1:100

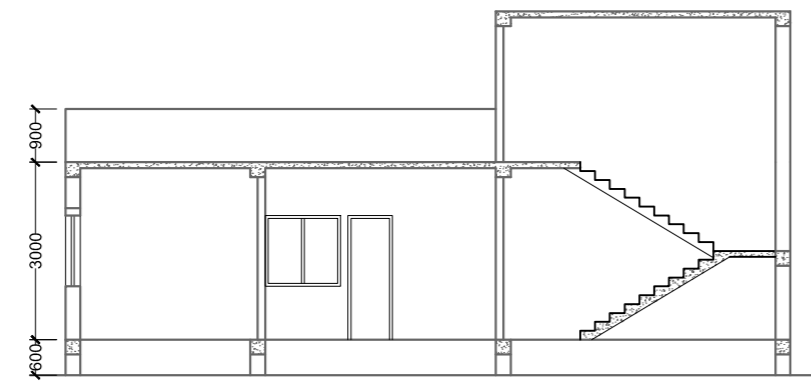

SECTION B-B
Scale - 1:100

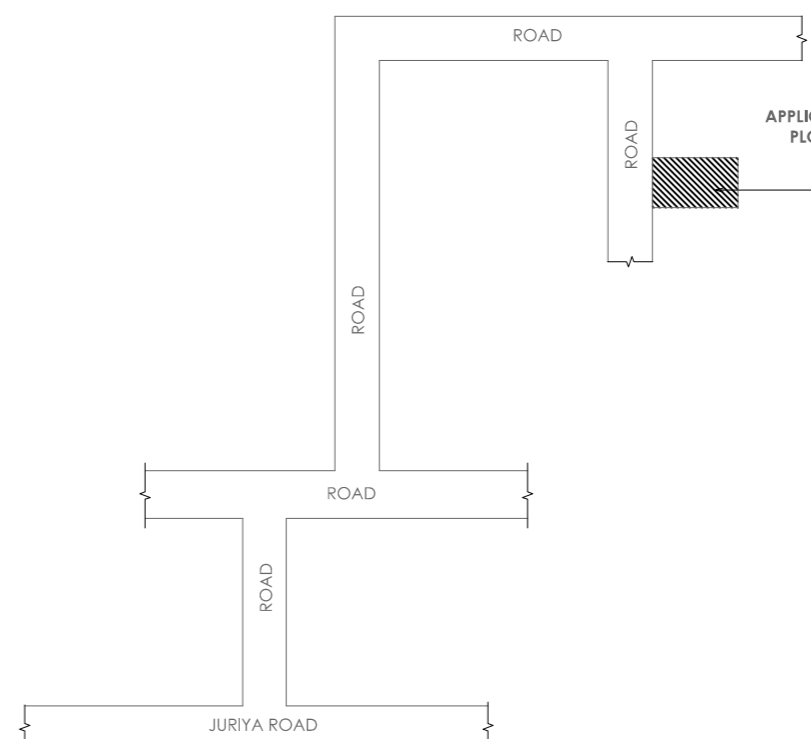
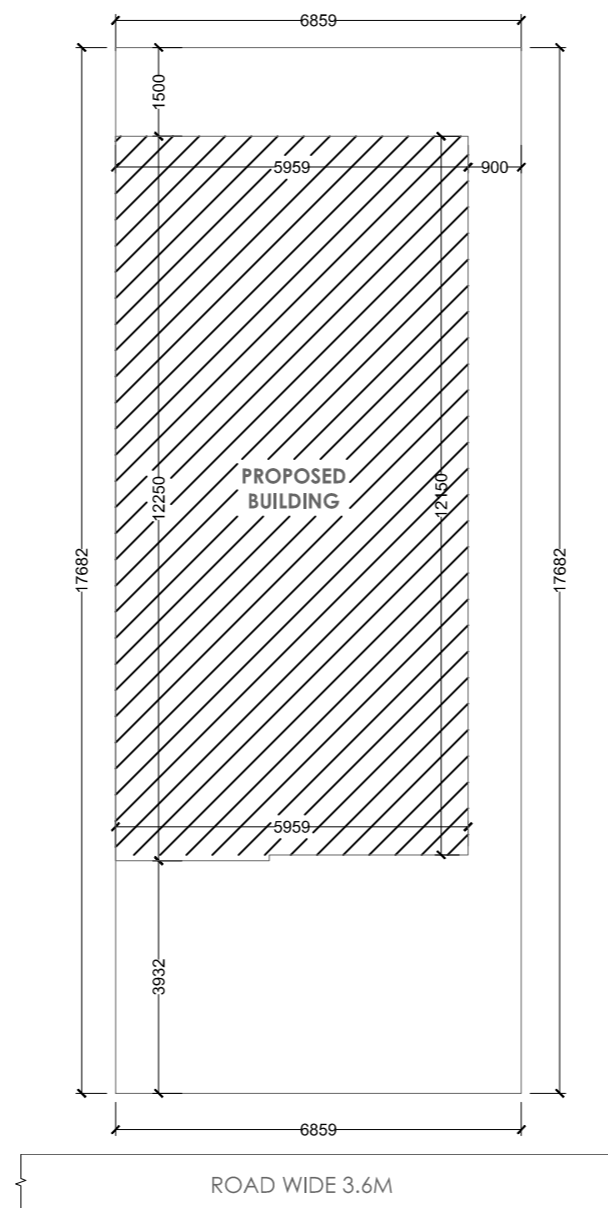
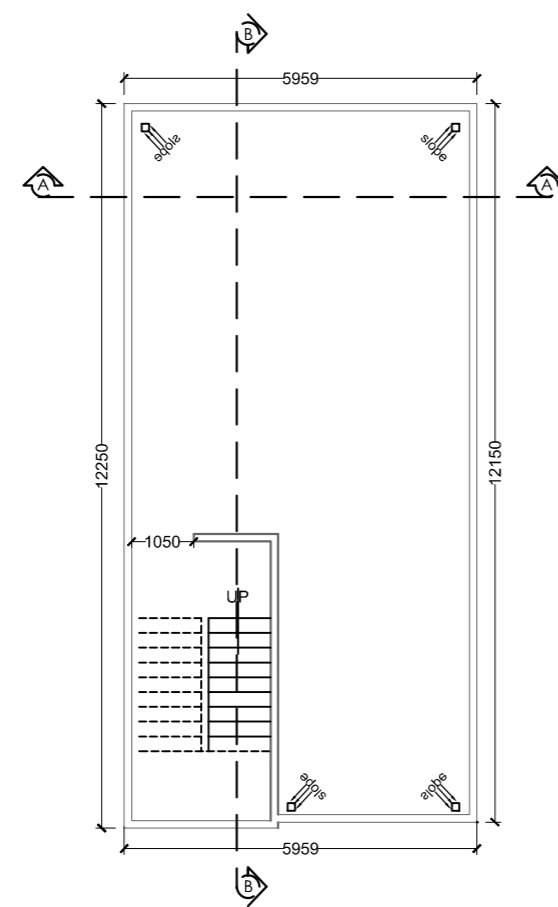
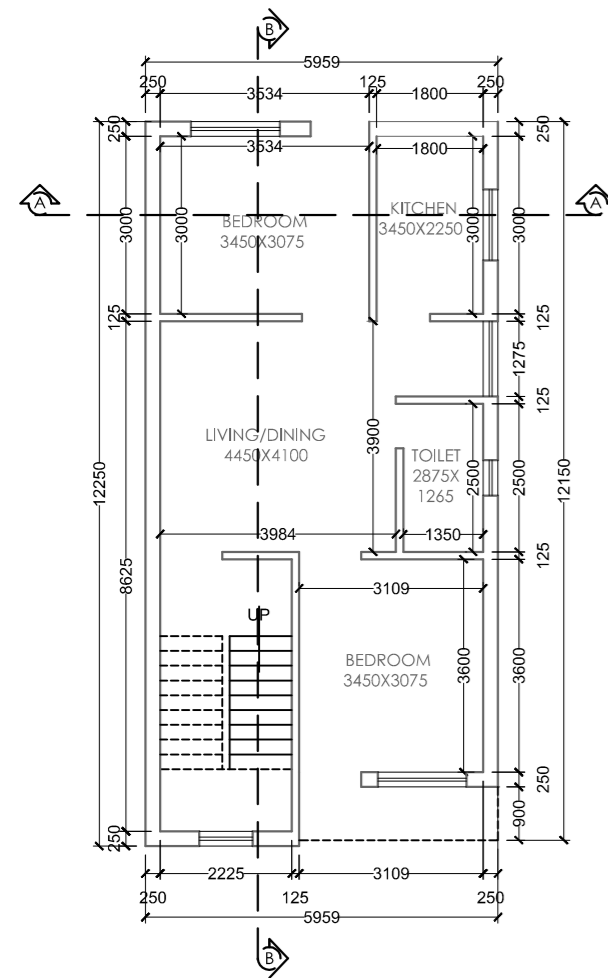
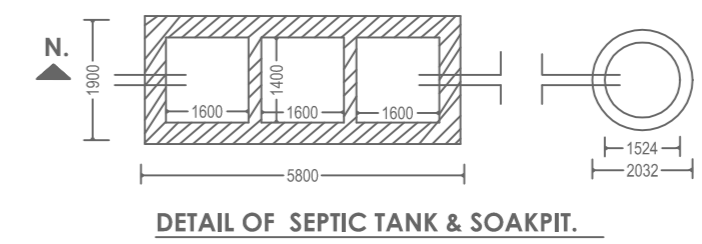
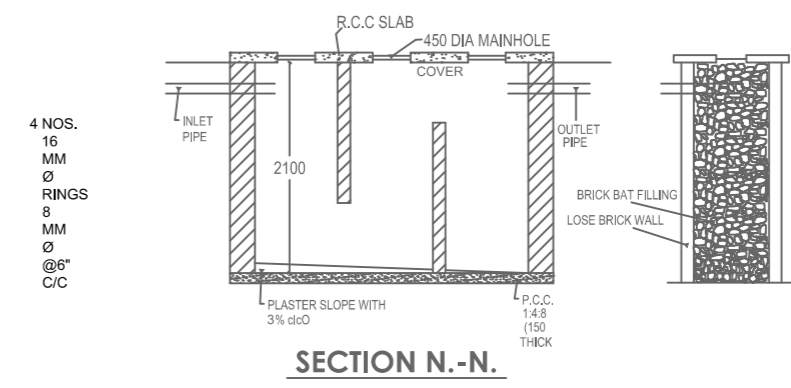
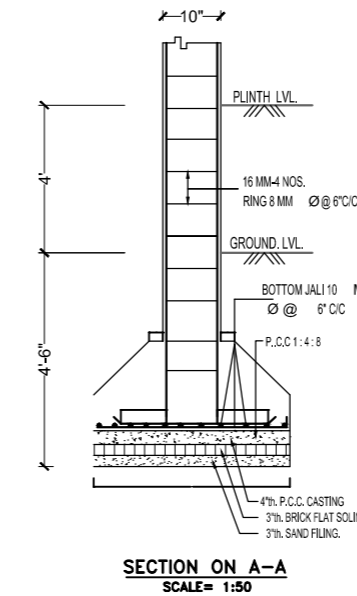
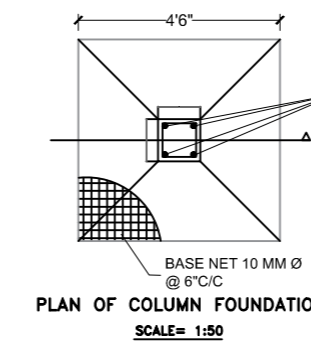
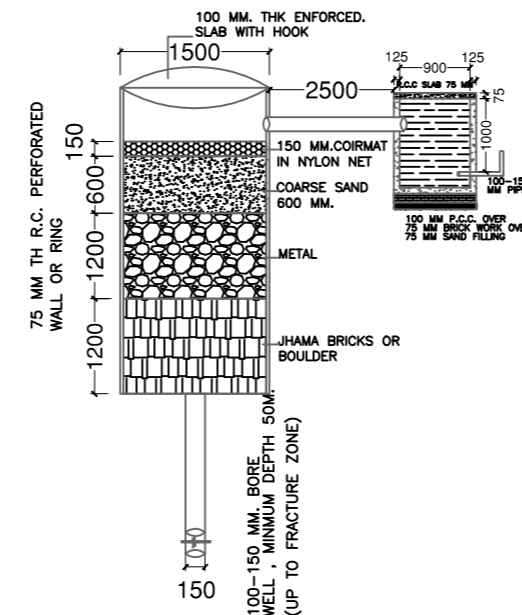
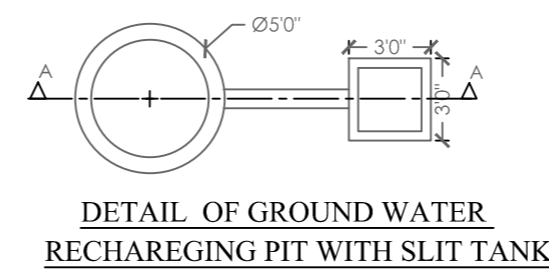

General notes	
1	ALL DIMENSION ARE IN MILLIMETRES UNLESS OTHERWISE STATED.
2	NO DIMENSION IS TO BE SCALED OFF THE DRAWING.
3	DRAWINGS TO BE READ IN CONJUNCTION WITH ALL RELEVANT DRAWINGS & SPECIFICATIONS.
4	REFER WRITTEN DIMENSIONS ONLY.
5	DOORS AND WINDOW FRAME NOT TO BE FIXED ALONG WITH BRICK WORK.
6	INTERNAL PLASTER SHOULD BE 12MM THICK AND EXTERNAL PLASTER IS 25MM THICK.
7	FOUNDATION DEPTH UPTO GOOD SOIL.
8	CEMENT MORTAR OF MIX (1:6) FOR ENTIRE STRUCTURE AND PLASTER WORK.
9	SEPTIC TANK WILL BE FLUSHING SYSTEM.
10	ALL REINFORCEMENT SHALL BE OF TOR STEEL OF GRADE FY-415.
11	GRADE OF CONCRETE SHALL BE M-20

	TYPE	WIDTH	HEIGHT	SILL LVL	DISCRIPTION
schedule of openings	D	1000	2100	NILL	SINGLE SHUTTER FLUSH DOOR
	D1	1000	2100	NILL	" "
	D2	900	2100	NILL	" "
	D3	700	2100	NILL	" "
	CG	1500	2100	NILL	STEEL CHANNEL GATE
	W	1500	1200	900	4 LEAF GLAZED WIND
	W2	1200	1200	900	" "
W3	900	1200	900	" "	
V	600	300	2400	VENTILATOR	

schedule of area		
PLOT AREA AS PER SITE	-	121.280 SQ.M.
AREA OF GROUND FLOOR	-	72.661 SQ.M.
TOTAL BUILD UP AREA	-	72.661 SQ.M.
% OF COVERED AREA	-	59.91%
TOTAL F.A.R. ACHIEVED	-	0.59

owner
PROPOSED GROUND FLOOR RESIDENTIAL BUILDING PLAN OF ASHIMA VISHWAKARMA, W/O PRAMIT KUMAR, PLOT NO. :- 716, KHATA NO. :- 272, THANA NO. :- 194, WARD NO. :- 15, AREA :- 3 DECIMAL, MAUZA :- LOHARDAGA, DIST - LOHARDAGA - 835302, STATE - JHARKHAND

architect
AH GROUP
Architecture & Design
New Road, Lohardaga (Jharkhand)
Mobile No: 9839426642
E-mail:- mdstauhaque265@gmail.com

SCALE: 1:100 (OTHER WISE SPECIFIED) (ALL DIM IN MM)
DATE: 3/11/2022
DEALT BY: E-ATAUL HAQUE

ENGINEER INCHARGE
SIGNATURE OF APPLICANT