

Proposal Basic Information

Proposal File No.	LNP/BP/0026/W07/2023
Owner Name	HINDALCO INDUSTRIES LIMITED MINES DIVISION
Khata No	34/112
Plot No	258 & 259
Village Name	Nadia
Use	Residential
SubUse	ResiComm Bldg

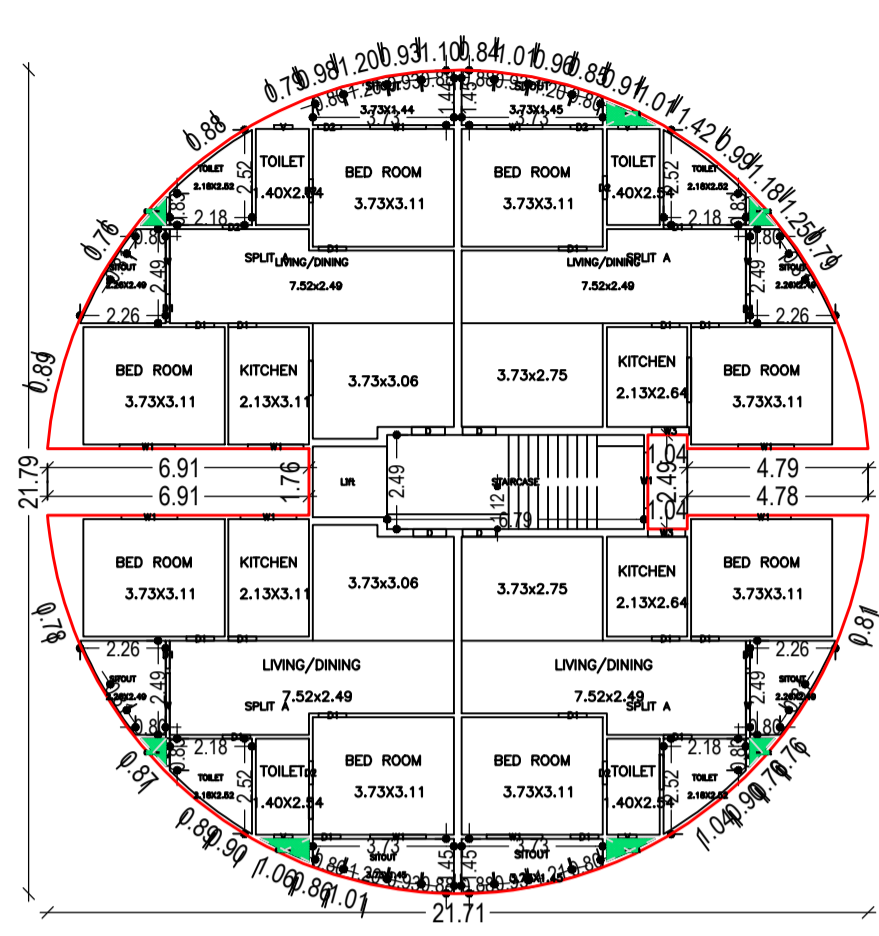

FOURTH FLOOR PLAN (Proposed)
SCALE 1:100

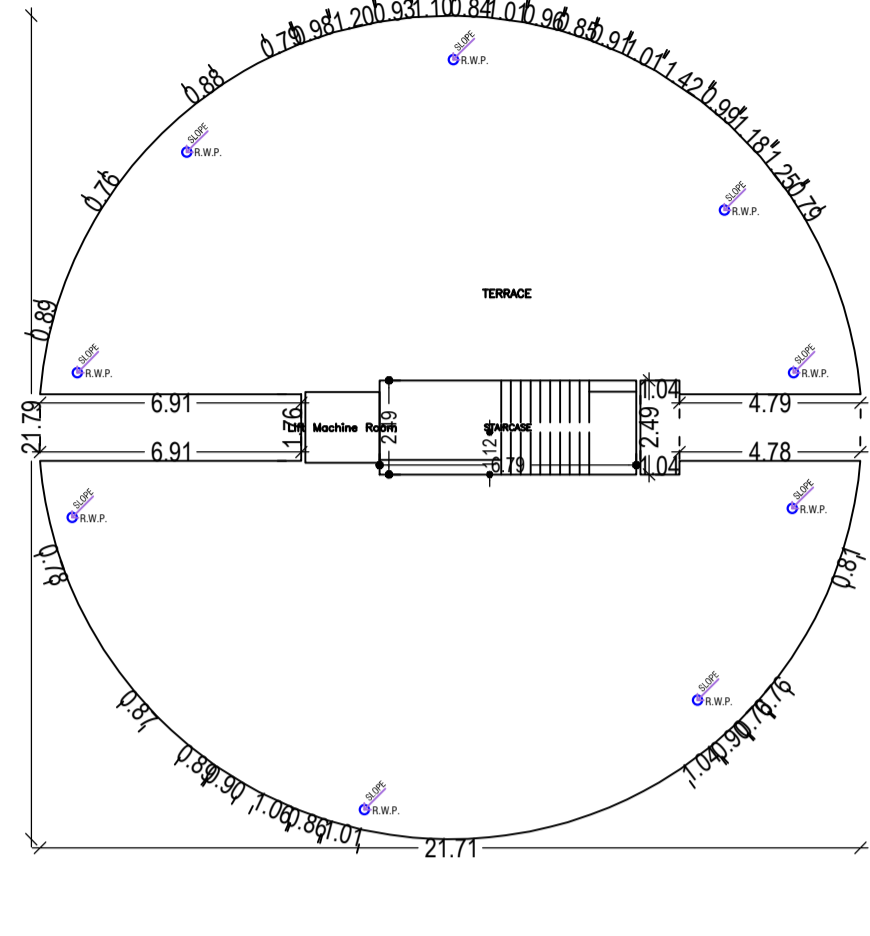

TERRACE FLOOR PLAN (Existing)
SCALE 1:100

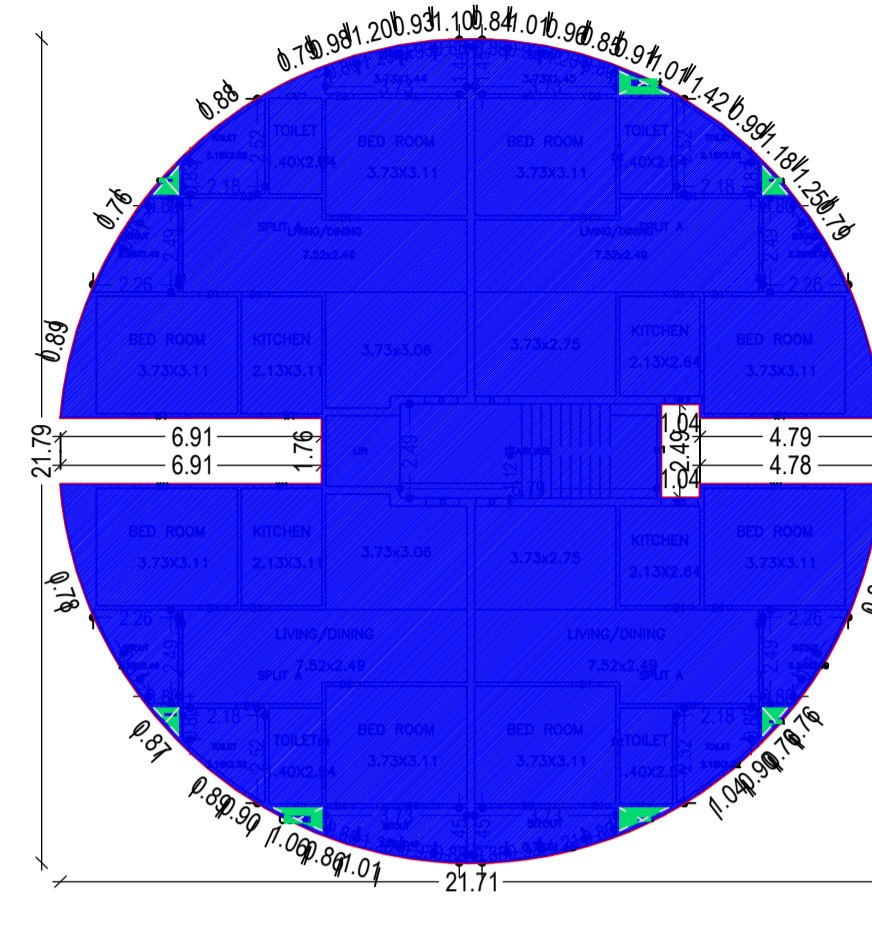

TYPICAL - 1, 2 & 3 FLOOR PLAN (Existing)
SCALE 1:100

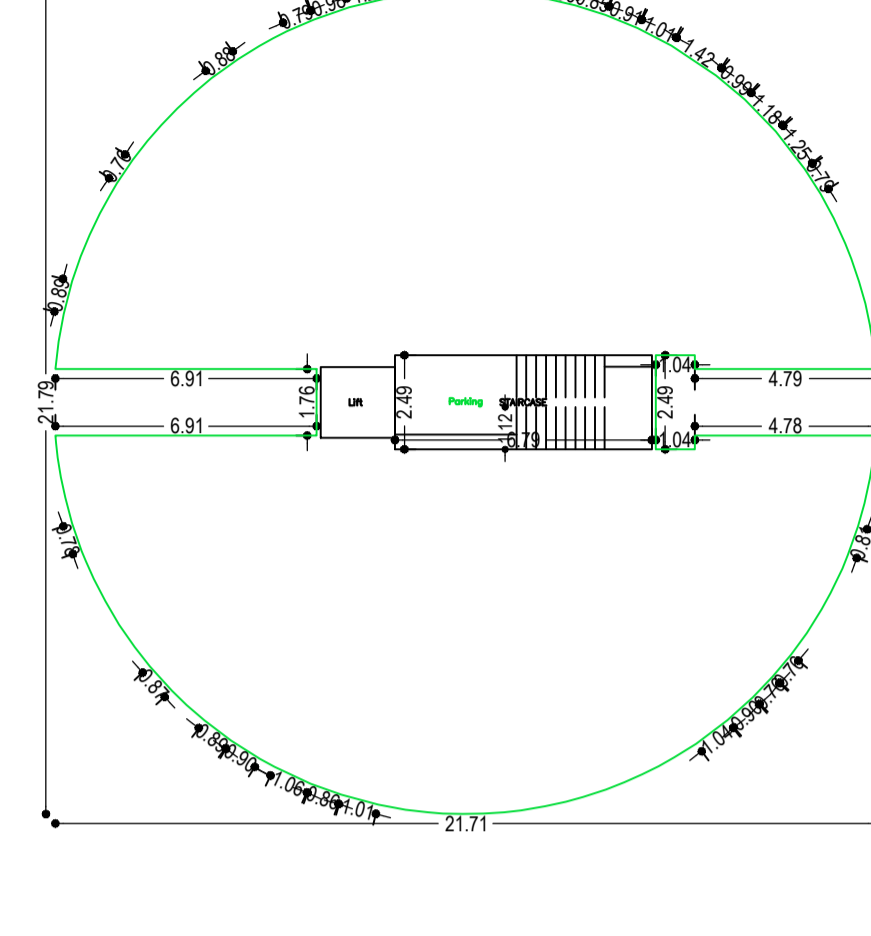

GROUND FLOOR PLAN (Existing)
SCALE 1:100

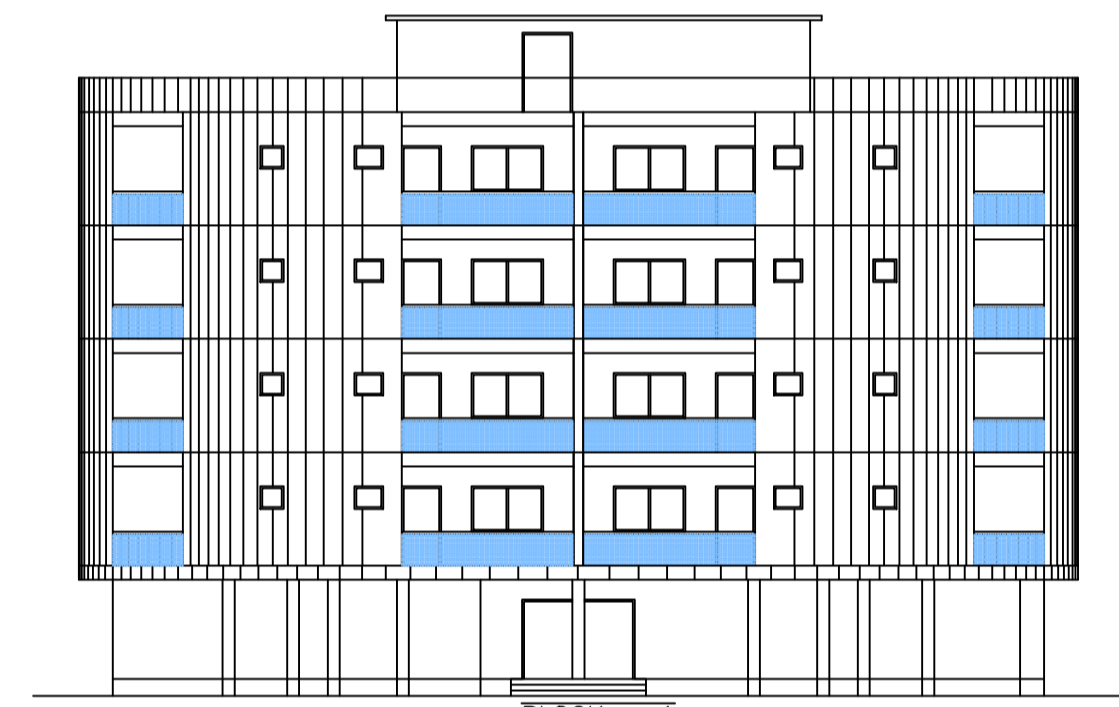
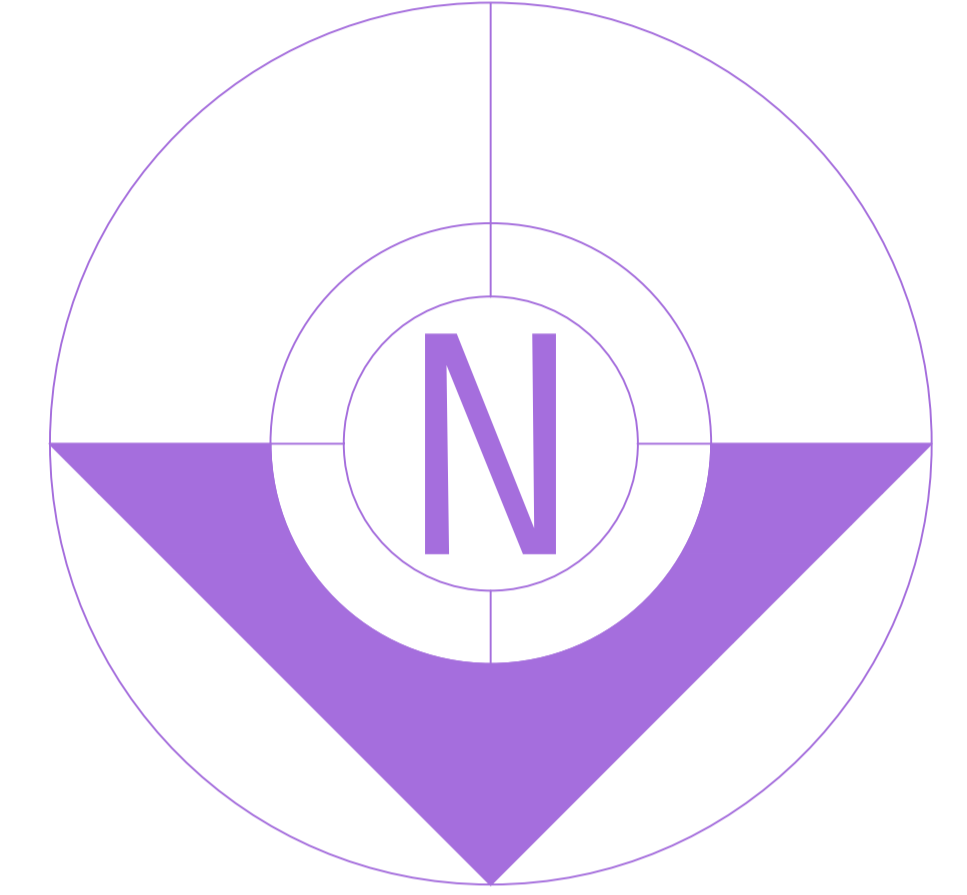

BLOCK - 1
SIDE - A
ELEVATION
SCALE - 1:100



BLOCK - 1
SIDE - D
ELEVATION
SCALE - 1:100

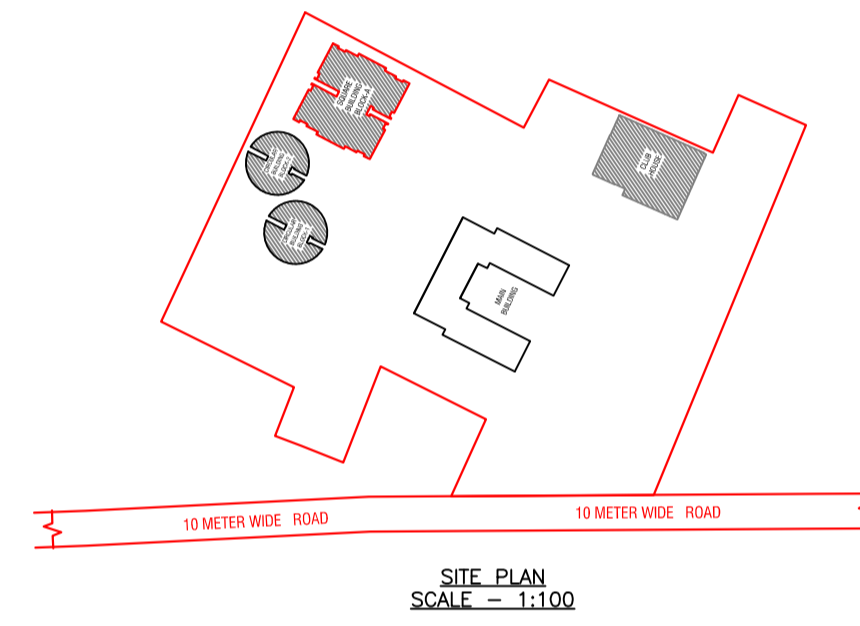

SITE PLAN
SCALE - 1:100

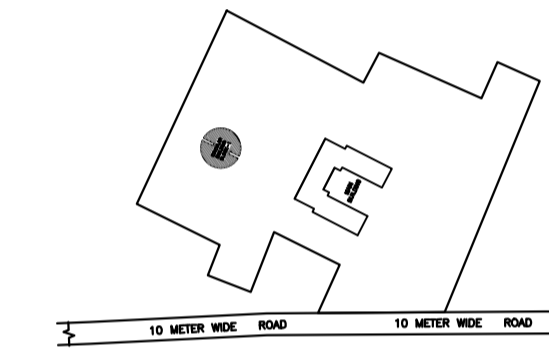

LOCATION PLAN
SCALE - N.T.S.

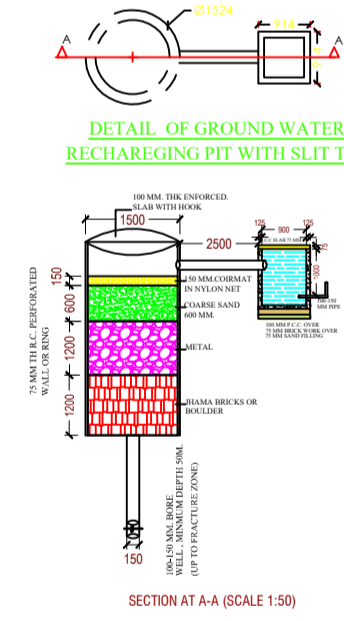

SECTION AT A-A (SCALE 1:50)

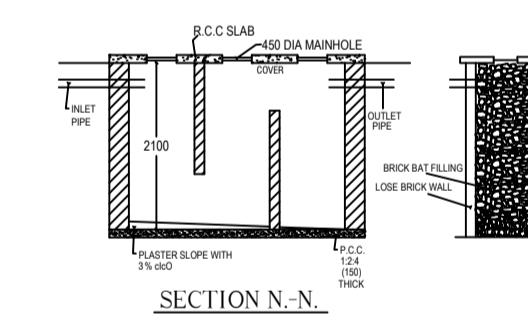

SECTION N-N

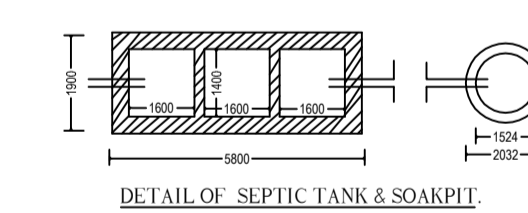

DETAIL OF SEPTIC TANK & SOAK PIT

Building :2 (BLOCK 2)

Floor Name	Gravel Area (Sq.Mt)	Concrete Area (Sq.Mt)	Total Area (Sq.Mt)	Proposed Area (Sq.Mt)	Existing Area (Sq.Mt)	Nett Area (Sq.Mt)	Area Ratio (%)	Total Area (Sq.Mt)	Total Concrete (Sq.Mt)	Total Gravel (Sq.Mt)
Ground Floor	348.00	0.00	348.00	0.00	348.00	0.00	0.00	348.00	0.00	348.00
1st Floor	348.00	2.17	348.00	0.00	348.00	0.00	0.00	348.00	2.17	348.00
2nd Floor	348.00	2.17	348.00	0.00	348.00	0.00	0.00	348.00	2.17	348.00
3rd Floor	348.00	2.17	348.00	0.00	348.00	0.00	0.00	348.00	2.17	348.00
4th Floor	348.00	2.17	348.00	0.00	348.00	0.00	0.00	348.00	2.17	348.00
Total	1740.00	8.71	1740.00	0.00	1740.00	0.00	0.00	1740.00	8.71	1740.00

SCHEDULE OF DOOR:

Building Name	Level	Location	Height	Qty
258/259	GF	01	2.10	2
258/259	GF	02	2.10	4
258/259	GF	03	2.10	4

SCHEDULE OF WINDOW/VENTILATION:

Building Name	Level	Location	Height	Qty
258/259	GF	01	2.10	2
258/259	GF	02	2.10	4
258/259	GF	03	2.10	4

Unit/BUA Table for Building :2 (BLOCK 2)

FLOOR	Name	Unit/BUA Type	Unit/BUA Area	Cover Area	No. of Rooms	No. of Residents
TYPICAL - 1	UNIT A	FLAT	100.00	100.00	1	1
	UNIT B	FLAT	100.00	100.00	1	1
	UNIT C	FLAT	100.00	100.00	1	1
	UNIT D	FLAT	100.00	100.00	1	1
FOURTH FLOOR PLAN	UNIT A	FLAT	100.00	100.00	1	1
	UNIT B	FLAT	100.00	100.00	1	1
	UNIT C	FLAT	100.00	100.00	1	1
	UNIT D	FLAT	100.00	100.00	1	1
Total						

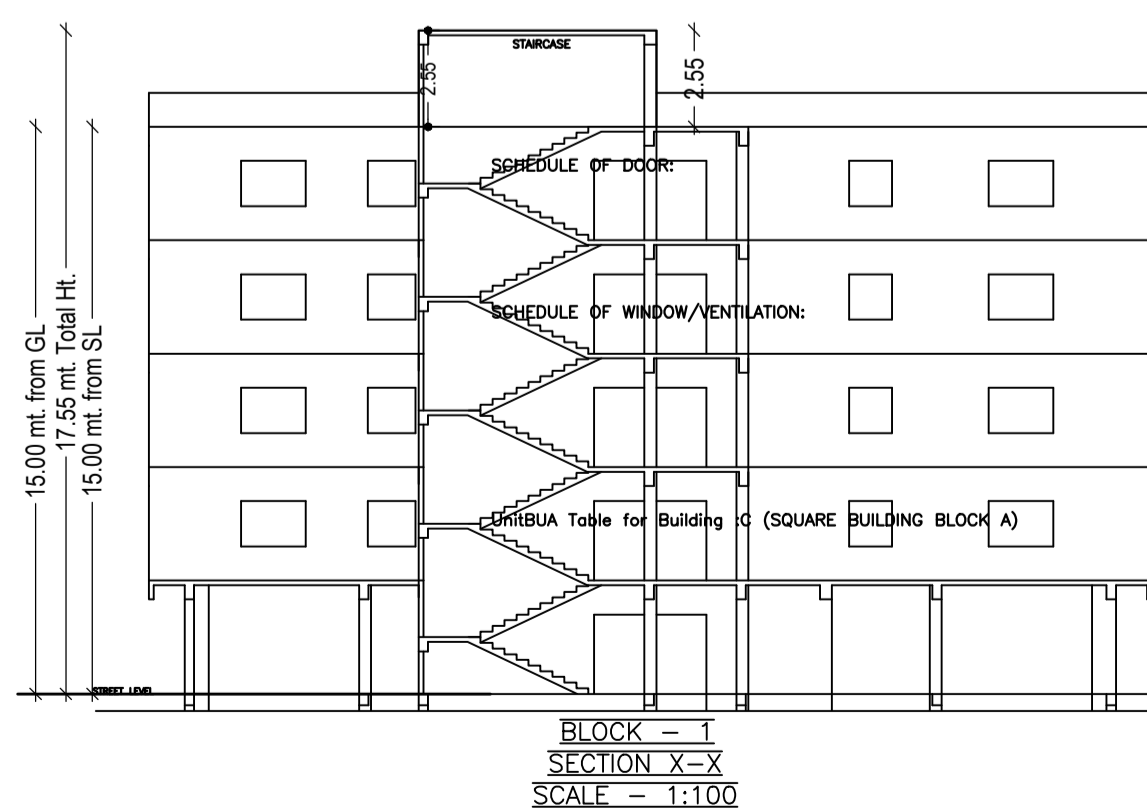

BLOCK - 1
SECTION X-X
SCALE - 1:100

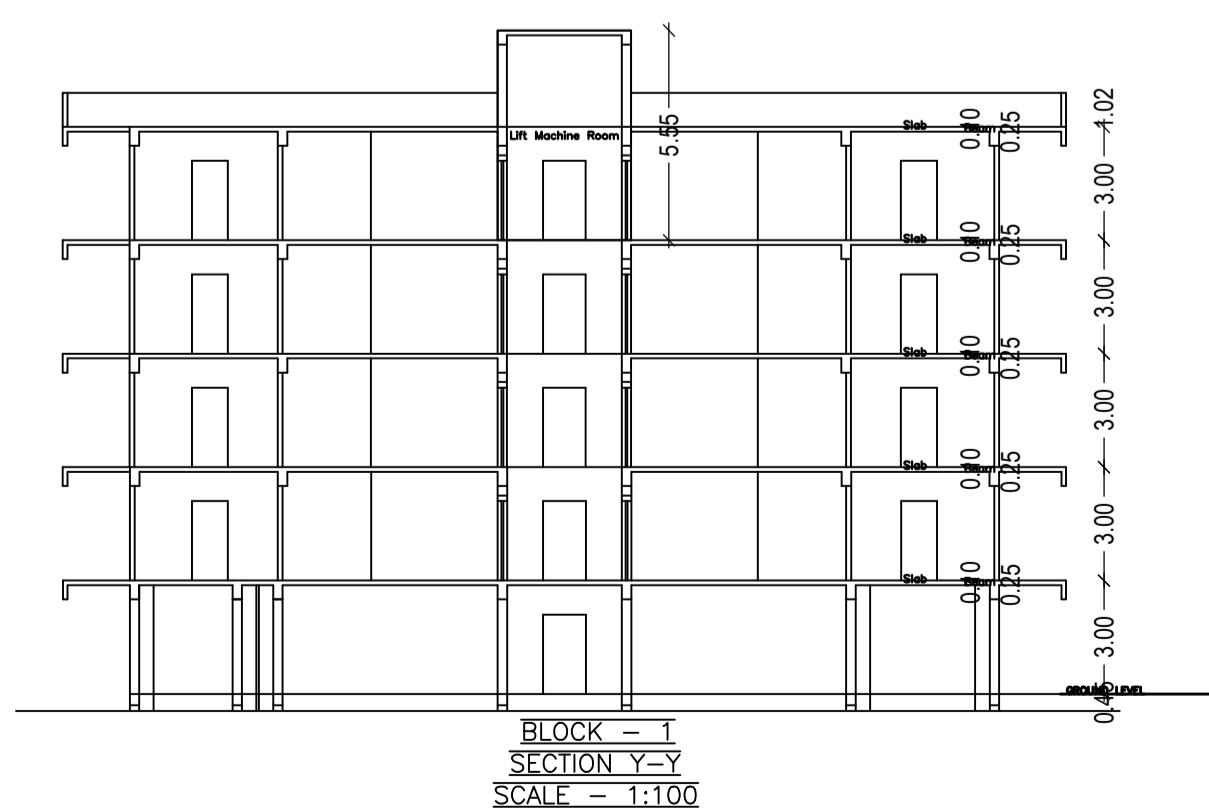

BLOCK - 1
SECTION Y-Y
SCALE - 1:100

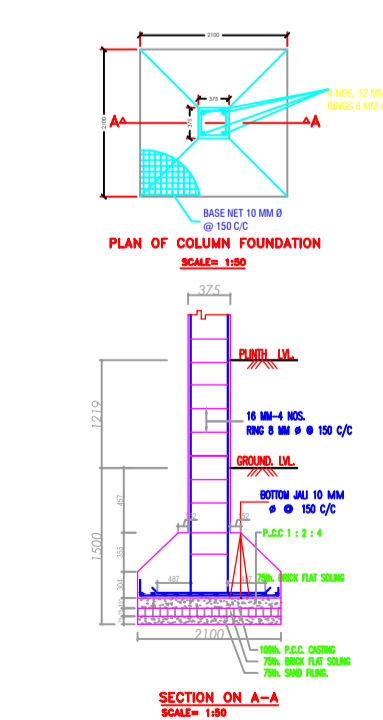

SECTION ON A-A
SCALE - 1:50

LTP NAME AND SIGNATURE ASHWINI KUMAR SAHU LNP/ENG/0005/2017	STRUCTURAL ENG'S NAME AND SIGNATURE	BUILDER NAME AND SIGNATURE	DIGITAL SIGNATURE
---	-------------------------------------	----------------------------	-------------------

Proposal Basic Information

Proposal File No.	LNP/BP/0026/W07/2023
Owner Name	HINDALCO INDUSTRIES LIMITED MINES DIVISION
Khata No	34/112
Plot No	258 & 259
Village Name	Nadia
Use	Residential
SubUse	ResiComm Bldg

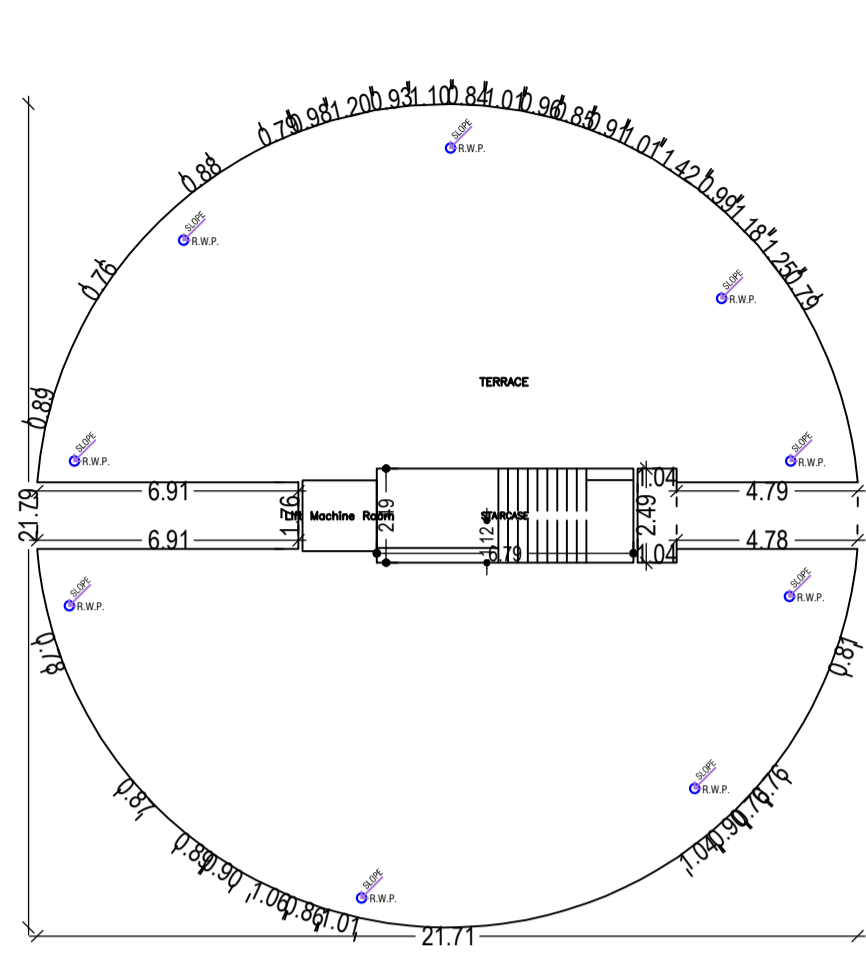

TERRACE FLOOR PLAN (SCALE 1:100)

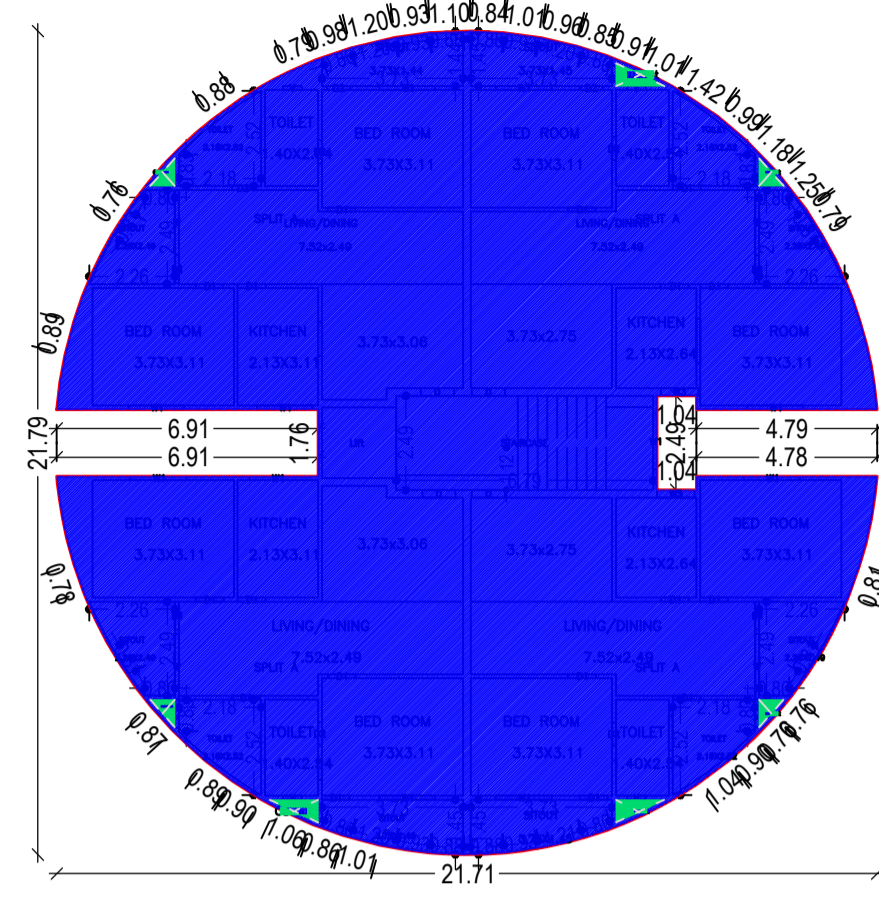

TYPICAL - 1, 2 & 3 FLOOR PLAN (Existing) (SCALE 1:100)

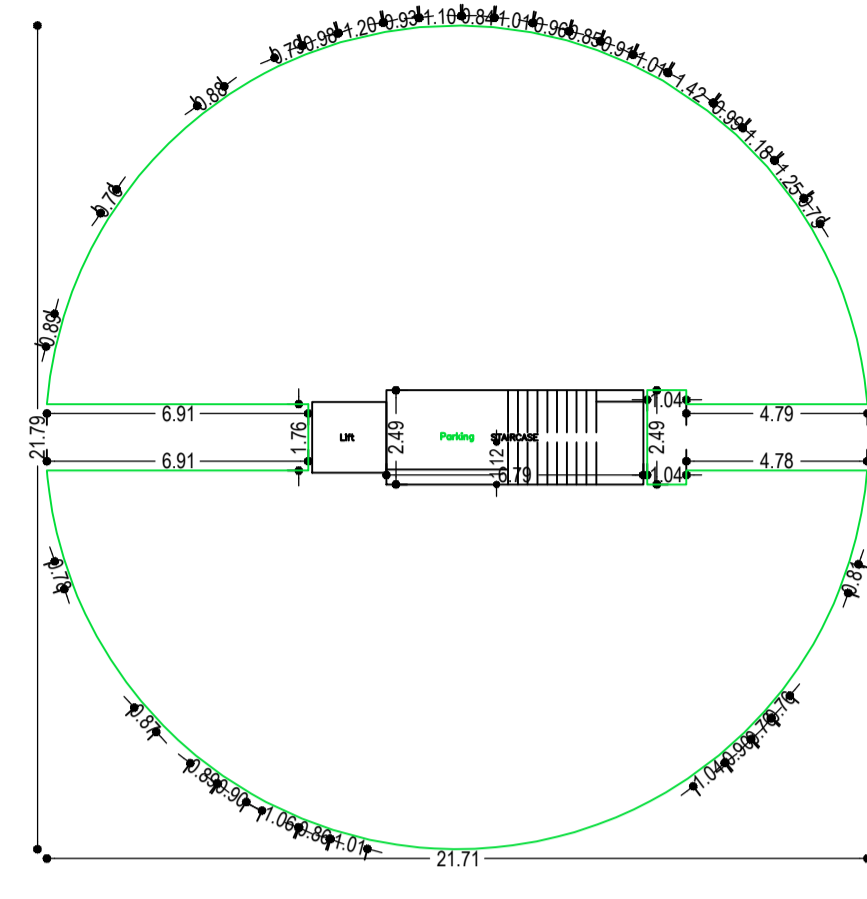

GROUND FLOOR PLAN (SCALE 1:100)

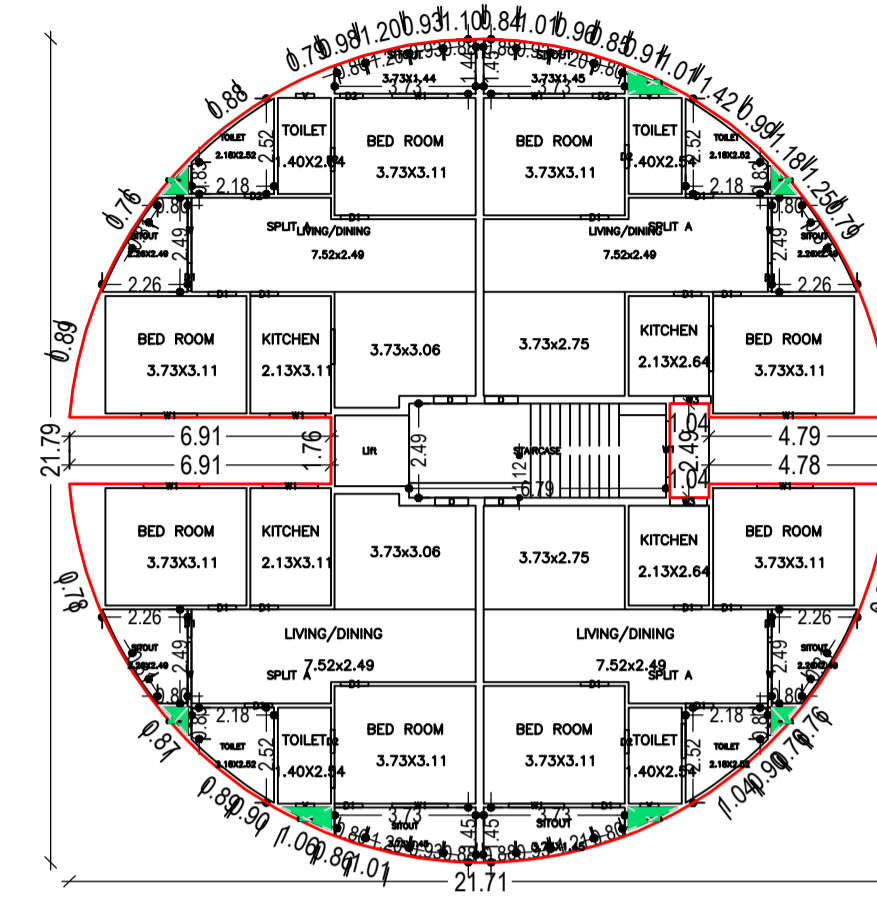

FOURTH FLOOR PLAN (Proposed) (SCALE 1:100)

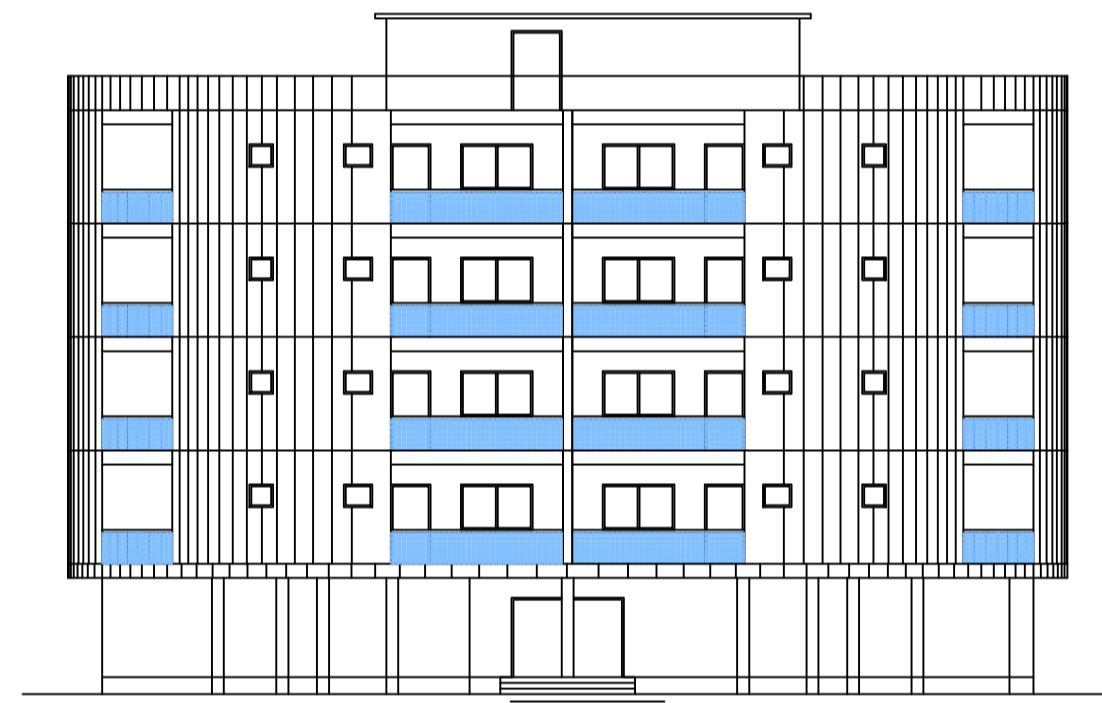
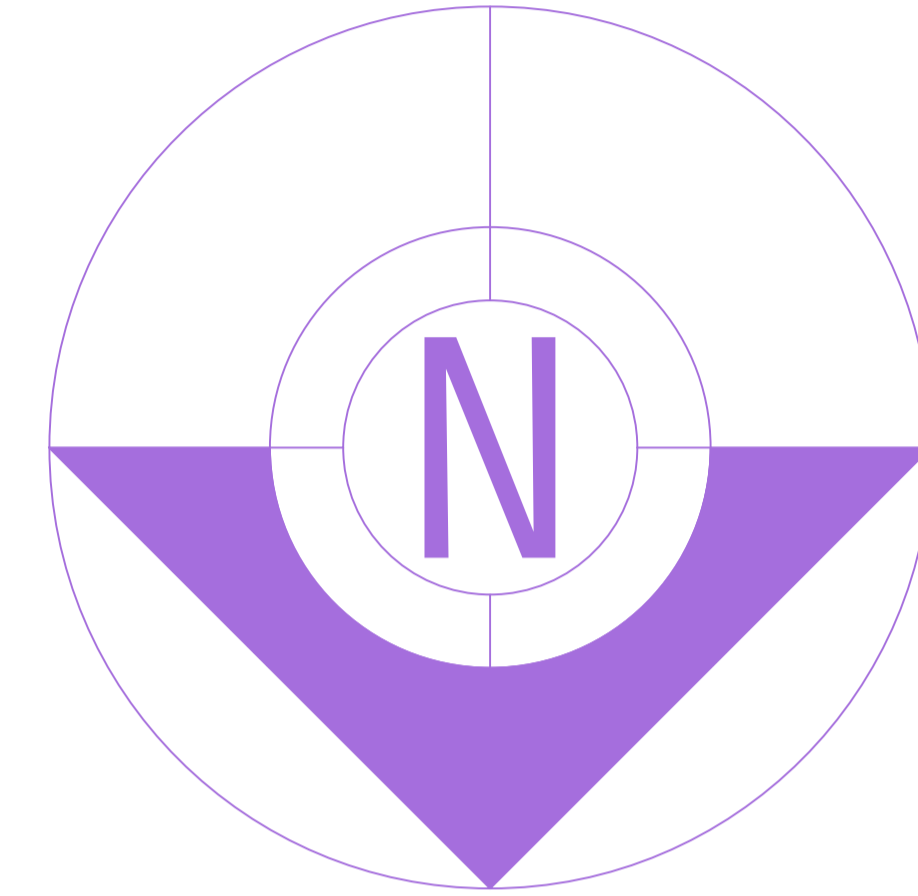

BLOCK - 1 SIDE - A ELEVATION (SCALE - 1:100)



BLOCK - 1 SIDE - D ELEVATION (SCALE - 1:100)

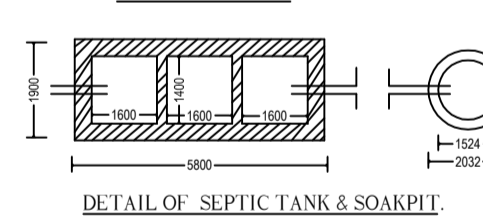
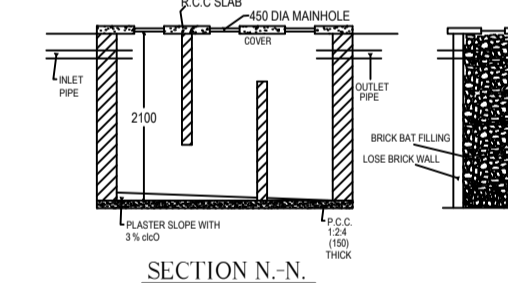
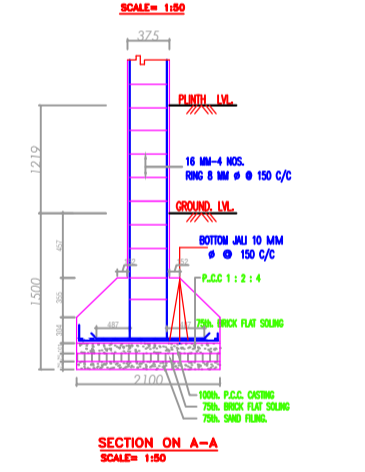
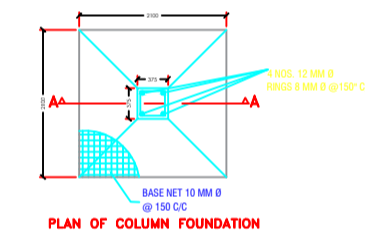

UnitBUA Table for Building -A (BLOCK 1)

FLOOR	Name	UnitBUA Type	Entry Type	UnitBUA Area (Sq.Mt)	Column Area (Sq.Mt)	No. of Rooms	% of Standard
TYPICAL - 1, 2 & 3 FLOOR PLAN	UNIT A	FLAT	Existing	102.80	102.80	3	1
FOURTH FLOOR PLAN	UNIT A	FLAT	Proposed	102.80	102.80	3	1
TOTAL				205.60	205.60	6	2

SCHEDULE OF DOOR:

BLOCK NAME	NAME	LENGTH	HEIGHT	NO.
A-BLOCK-1	D	1.20	2.10	20
A-BLOCK-1	E	1.20	2.10	20
A-BLOCK-1	F	1.20	2.10	20

SCHEDULE OF WINDOW/VENTILATION:

BLOCK NAME	NAME	LENGTH	HEIGHT	NO.
A-BLOCK-1	V	1.20	1.50	10
A-BLOCK-1	W	1.20	1.50	10
A-BLOCK-1	X	1.20	1.50	10
A-BLOCK-1	Y	1.20	1.50	10

Building -A (BLOCK 1)

Floor Name	Gross Built-up Area (Sq.Mt)	Net Built-up Area (Sq.Mt)	Total Area (Sq.Mt)	Existing Area (Sq.Mt)	Proposed Area (Sq.Mt)	Debiture Area (Sq.Mt)	Existing FAR Area (Sq.Mt)	Proposed FAR Area (Sq.Mt)	Add. FAR Area (Sq.Mt)	Total FAR Area (Sq.Mt)	Total Coverage (Sq.Mt)	Total Plot Area (Sq.Mt)	Floor No.
Ground Floor	348.24	0.00	348.24	0.00	348.24	0.00	0.00	16.92	25.99	25.99	0.00	0.00	01
1st Floor	348.24	2.17	348.91	0.00	348.91	0.00	0.00	16.92	25.99	348.24	348.24	0.00	02
2nd Floor	348.24	2.17	348.91	0.00	348.91	0.00	0.00	16.92	25.99	348.24	348.24	0.00	03
3rd Floor	348.24	2.17	348.91	0.00	348.91	0.00	0.00	16.92	25.99	348.24	348.24	0.00	04
4th Floor	348.24	2.17	348.91	0.00	348.91	0.00	0.00	16.92	25.99	348.24	348.24	0.00	05
Roof	0.00	0.00	0.00	0.00	0.00	0.00	0.00	0.00	0.00	0.00	0.00	0.00	06
Total	1382.96	6.51	1389.47	0.00	1389.47	0.00	0.00	67.68	103.96	1389.47	1389.47	0.00	07
Total	1382.96	6.51	1389.47	0.00	1389.47	0.00	0.00	67.68	103.96	1389.47	1389.47	0.00	08

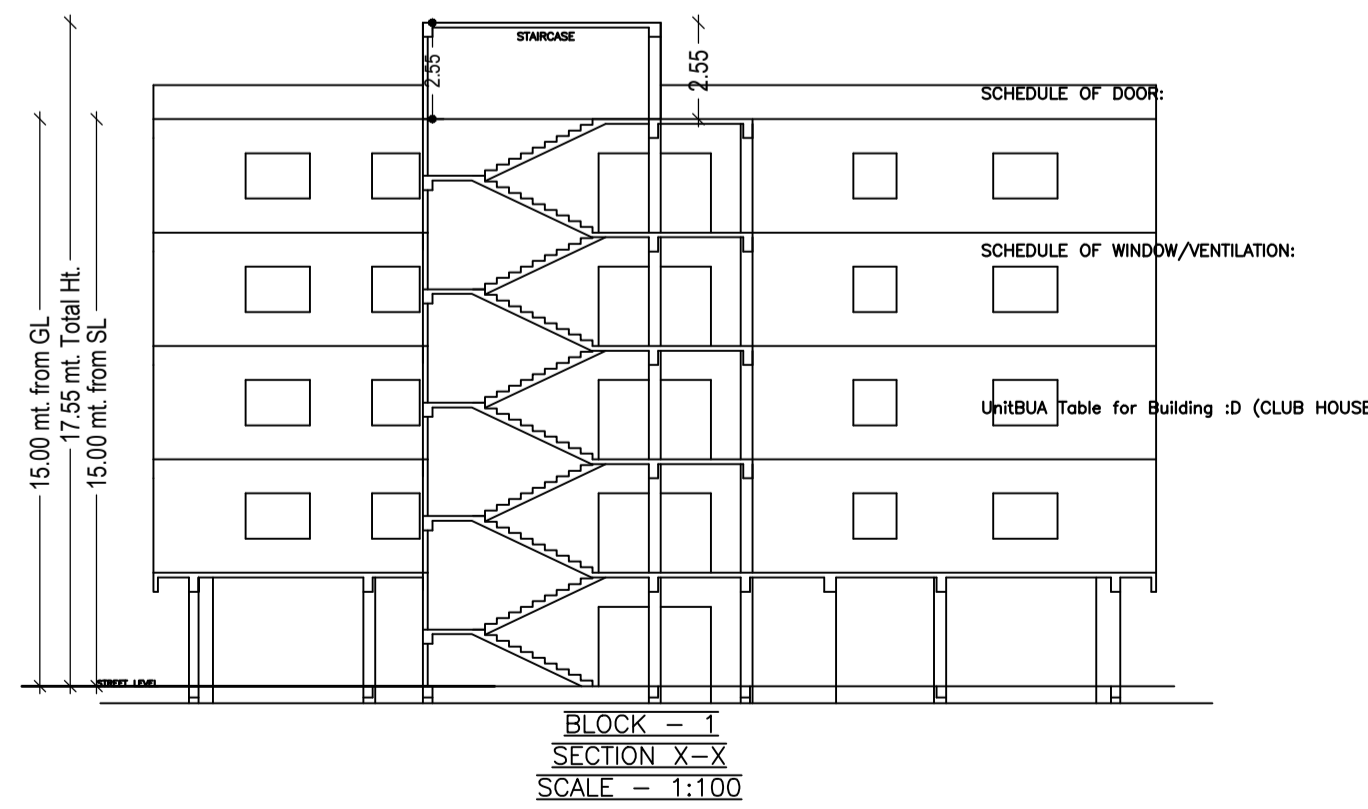

BLOCK - 1 SECTION X-X (SCALE - 1:100)

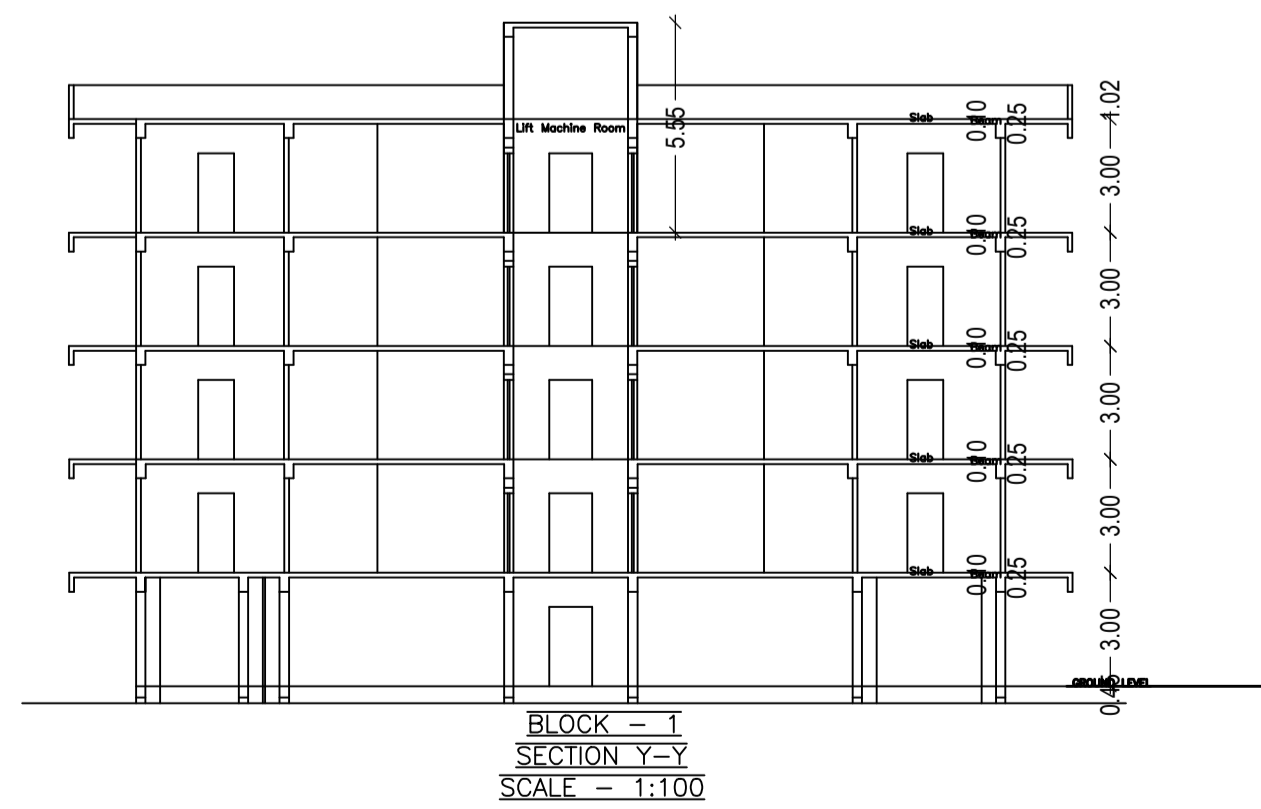

BLOCK - 1 SECTION Y-Y (SCALE - 1:100)

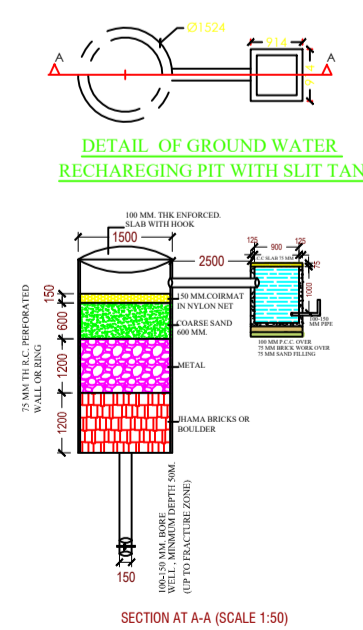

SECTION AT A-A (SCALE 1:50)

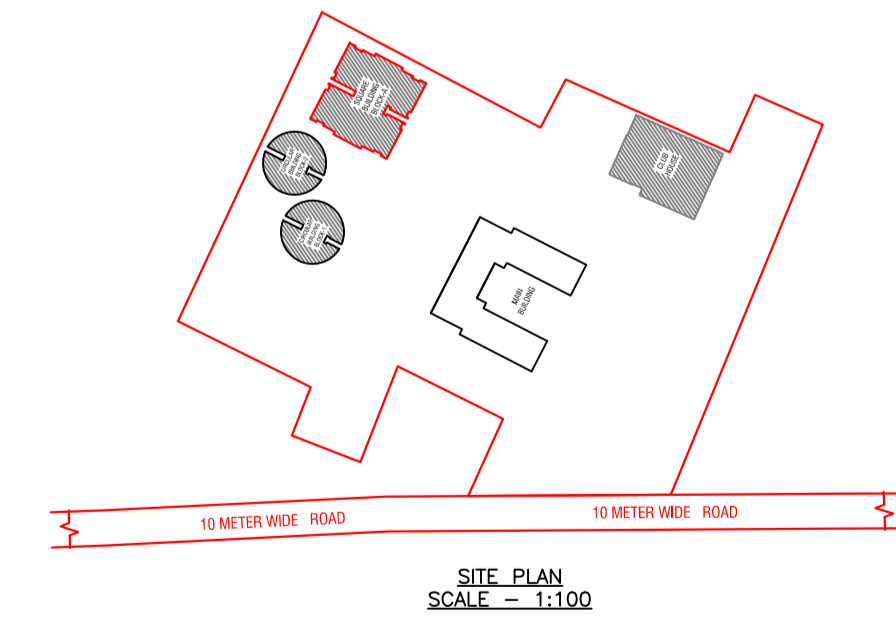

SITE PLAN (SCALE - 1:100)

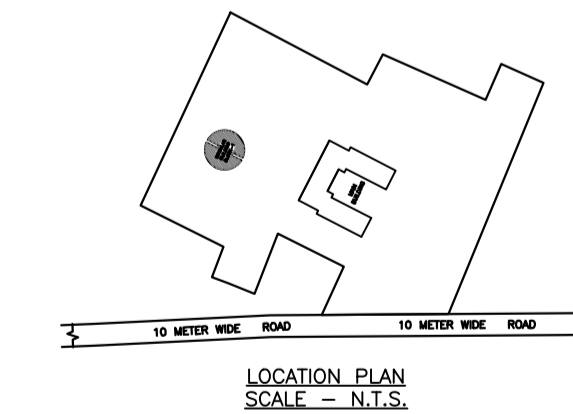

LOCATION PLAN (SCALE - N.T.S.)

LTP NAME AND SIGNATURE ASHWINI KUMAR SAHU LNP/ENG/0005/2017	STRUCTURAL ENG'S NAME AND SIGNATURE	BUILDER NAME AND SIGNATURE	DIGITAL SIGNATURE
---	-------------------------------------	----------------------------	-------------------

Proposal Basic Information

Proposal File No.	LNP/EP/0026/W07/2023
Owner Name	HINDALCO INDUSTRIES LIMITED MINES DIVISION
Khata No	34/112
Plot No	258 & 259
Village Name	Nadia
Use	Residential
SubUse	ResiComm Bldg

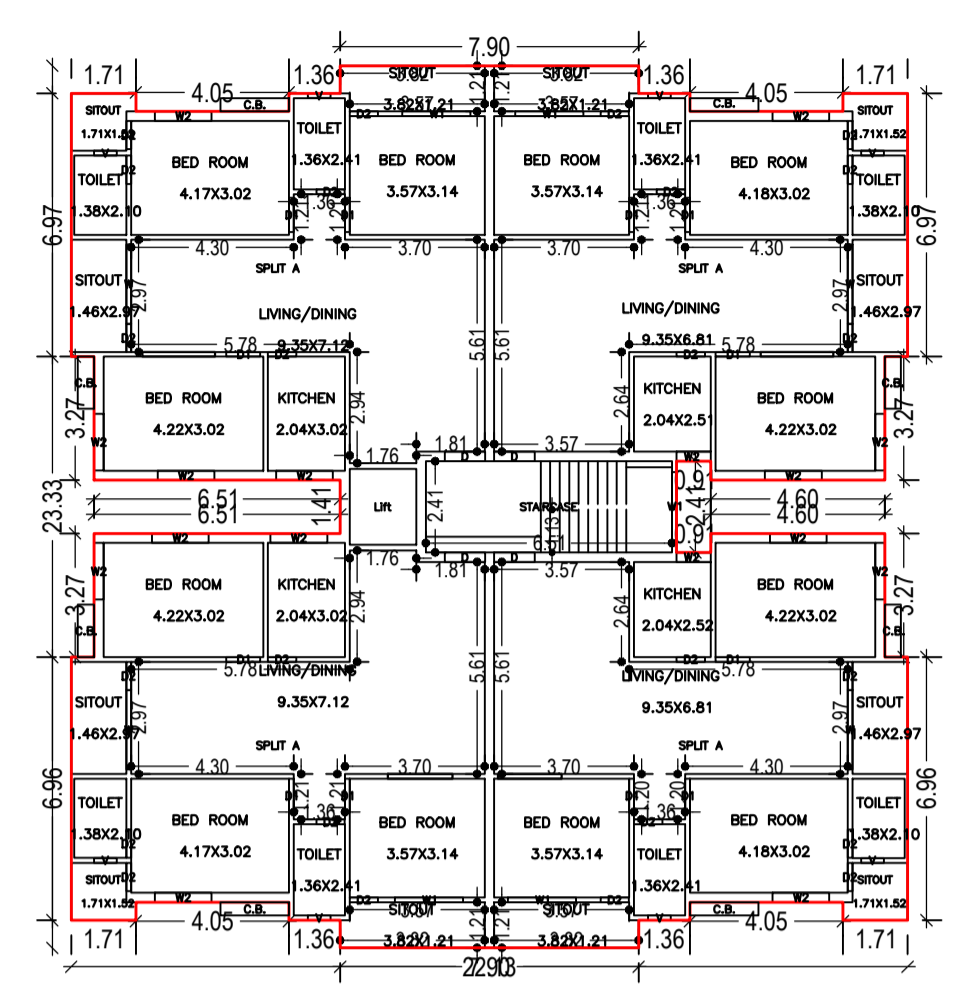

FOURTH FLOOR PLAN (Proposed)
SCALE 1:100

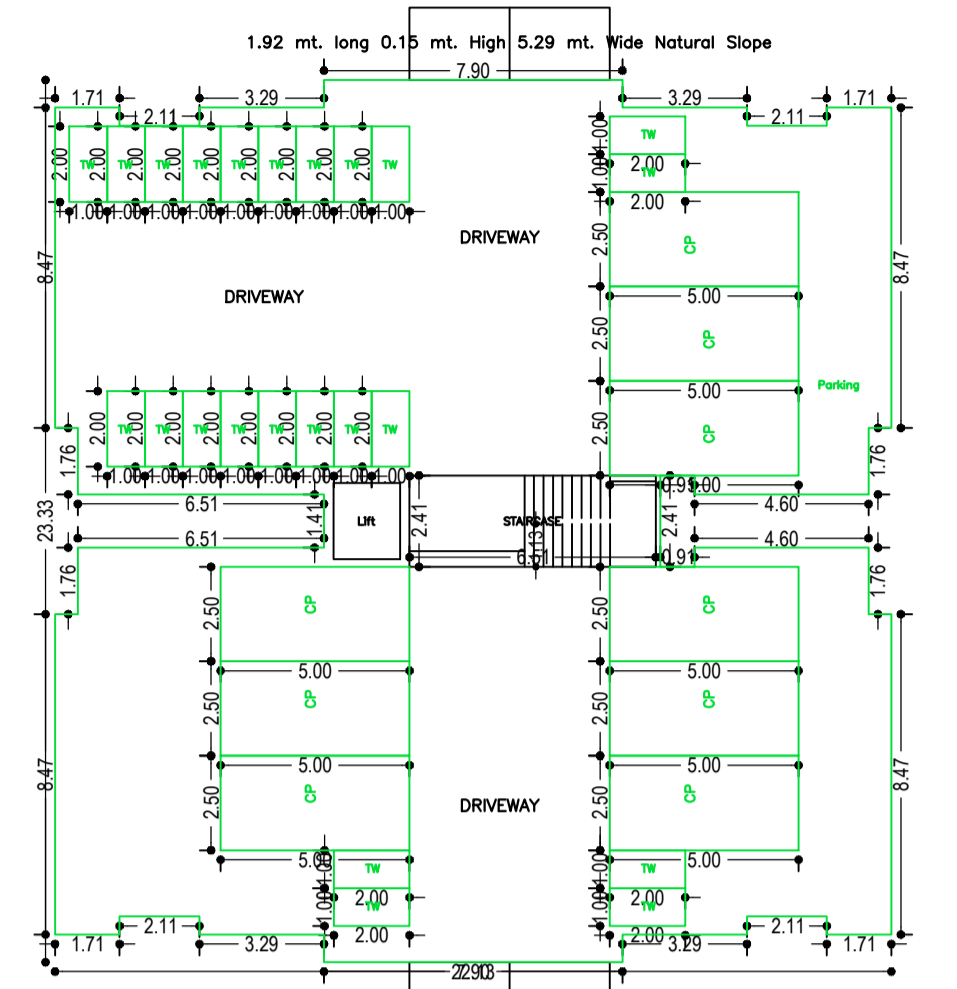

GROUND FLOOR PLAN (Existing)
SCALE 1:100

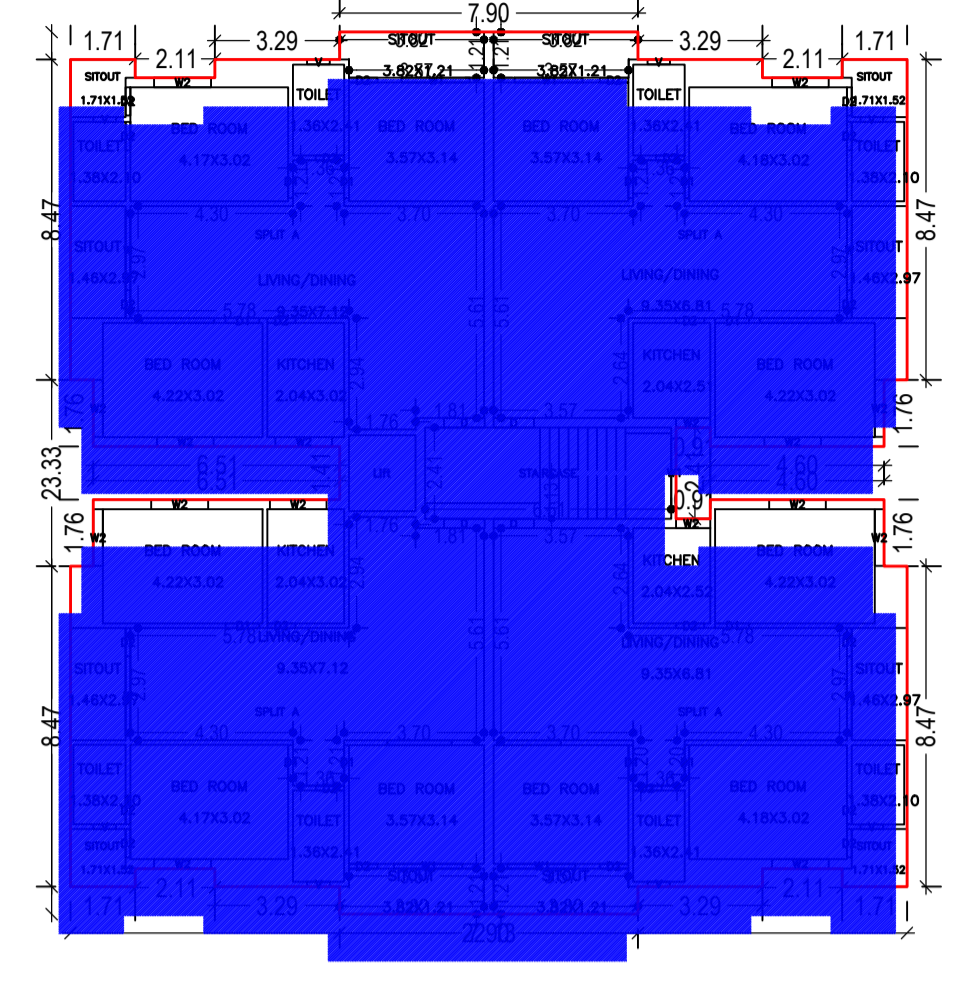

TYPICAL - 1, 2 & 3 FLOOR PLAN (Existing)
SCALE 1:100

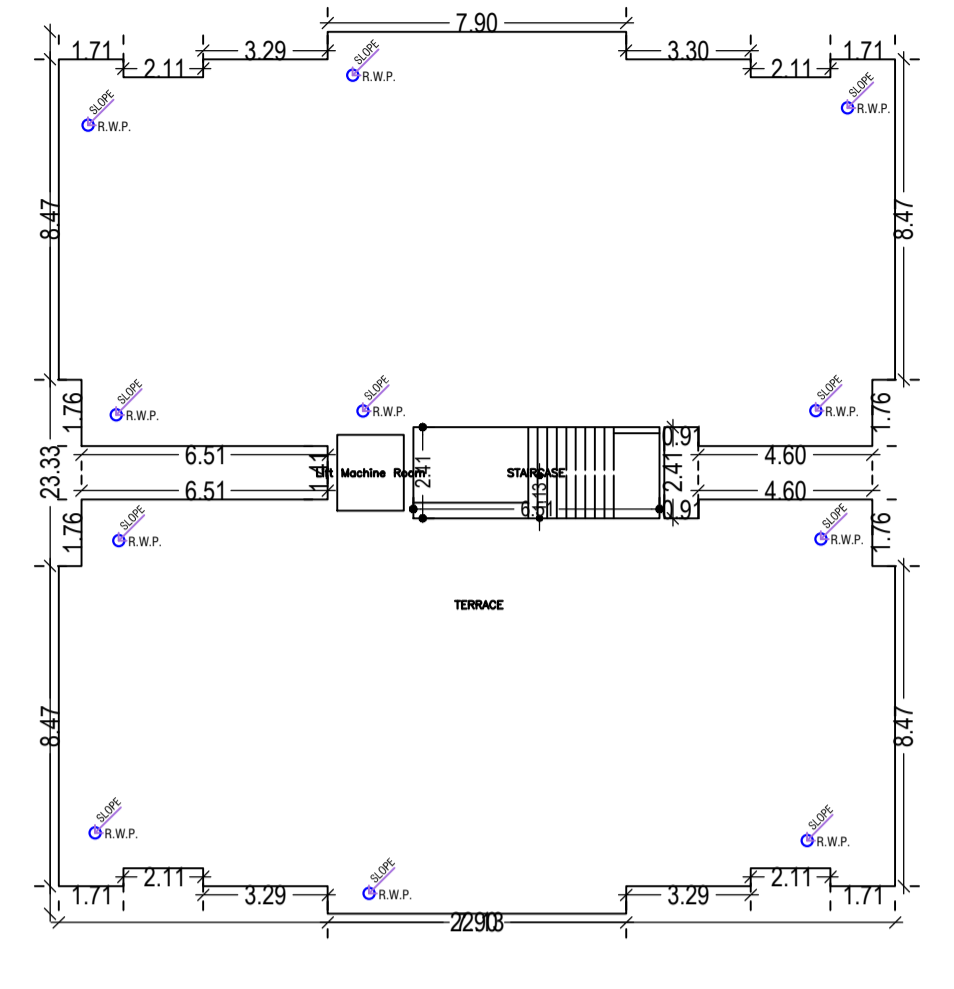

TERRACE FLOOR PLAN (SCALE 1:100)

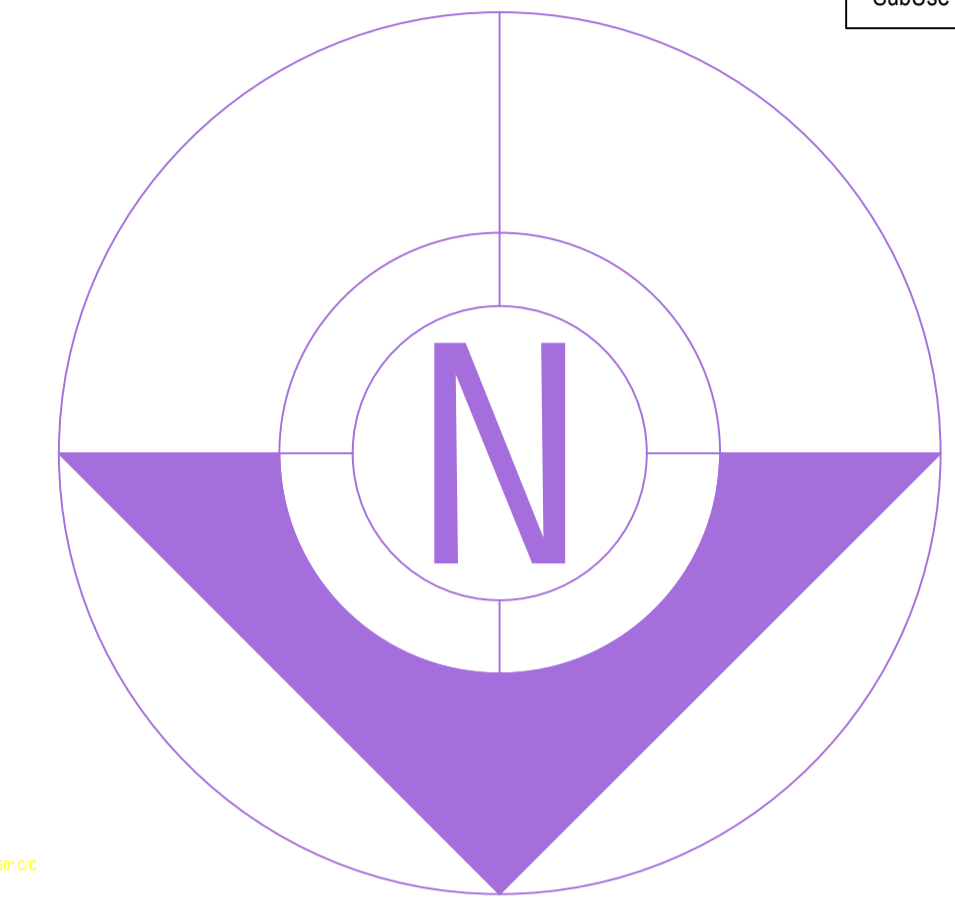

Project Title : HINDALCO INDUSTRIES LIMITED MINES DIVISION



SIDE - A ELEVATION
SCALE - 1:100

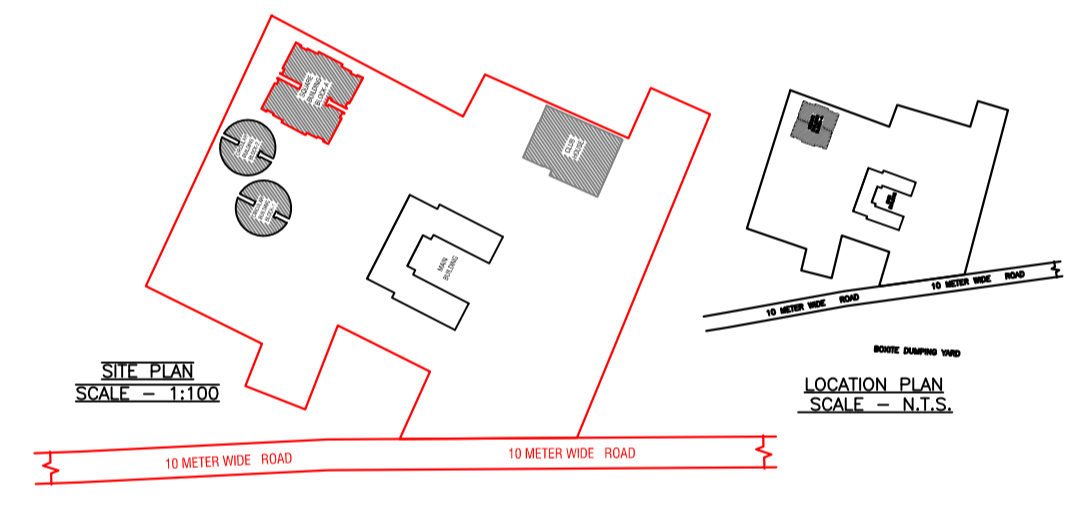

SITE PLAN SCALE - 1:100

LOCATION PLAN SCALE - N.T.S.

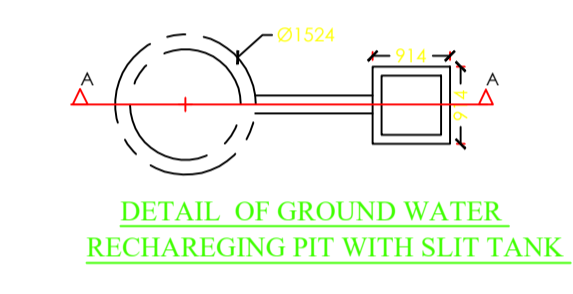

DETAIL OF GROUND WATER RECHARGING PIT WITH SLIT TANK

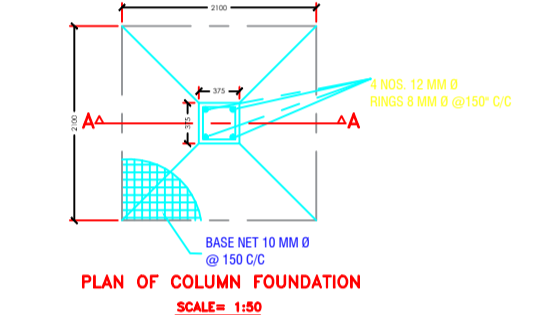

PLAN OF COLUMN FOUNDATION SCALE= 1:50

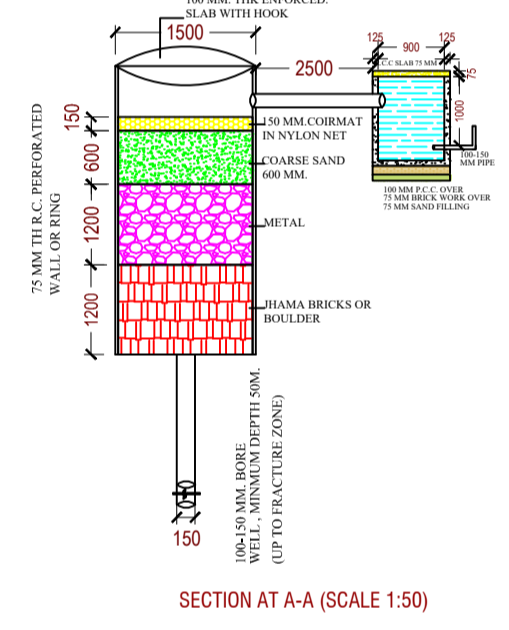

SECTION AT A-A (SCALE 1:50)

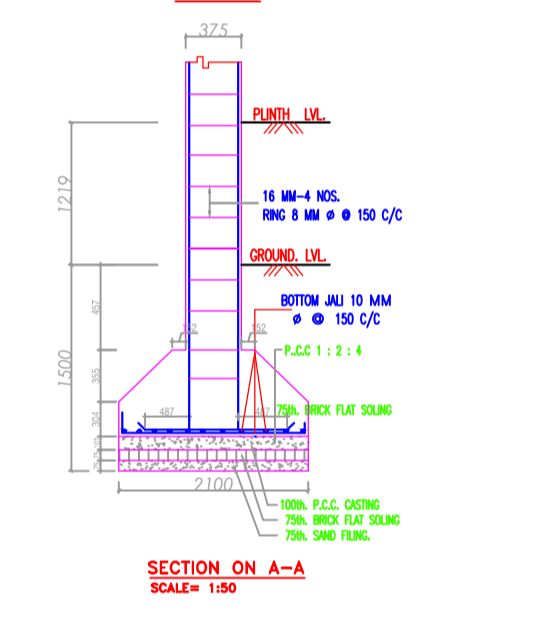

SECTION ON A-A SCALE= 1:50

UnitBUA Table for Building :C (SQUARE BUILDING BLOCK A)

FLOOR	Name	UNIT/Type	Entry Type	UnitBUA Area (Sq.Mt)	Cover Area (Sq.Mt)	No. of Rooms	No. of Balconies
TYPICAL - 1, 2 & 3 FLOOR PLAN	FLAT A	FLAT	Covered	1087.39	1087.39	13	3
FOURTH FLOOR PLAN	FLAT A	FLAT	Uncovered	0.00	0.00	13	0
Total	FLAT A	TOTAL	Proposed	1087.39	1087.39	26	3

SCHEDULE OF DOOR:

BUILDING NAME	DOOR	NAME	LENGTH	HEIGHT	MSIS
2 FLOOR BUILDING BLOCK A	D1	0.75	2.10	18	
2 FLOOR BUILDING BLOCK A	D1	0.80	2.10	48	
2 FLOOR BUILDING BLOCK A	D	1.07	2.10	18	

SCHEDULE OF WINDOW/VENTILATION:

BUILDING NAME	WINDOW	NAME	LENGTH	HEIGHT	MSIS
2 FLOOR BUILDING BLOCK A	V	0.80	2.70	20	
2 FLOOR BUILDING BLOCK A	W2	0.90	2.70	18	
2 FLOOR BUILDING BLOCK A	W2	1.00	2.70	18	
2 FLOOR BUILDING BLOCK A	W1	1.80	2.70	20	
2 FLOOR BUILDING BLOCK A	W	2.10	2.70	18	

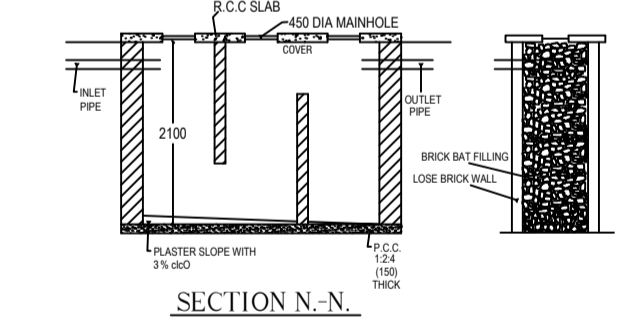

SECTION N-N

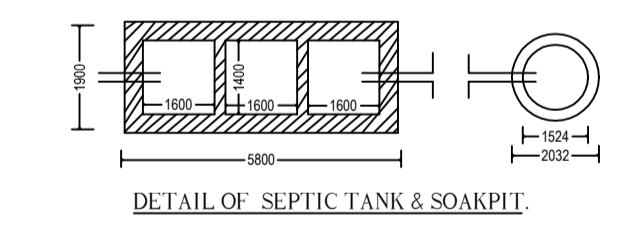

DETAIL OF SEPTIC TANK & SOAKPIT



SIDE - B ELEVATION
SCALE - 1:100

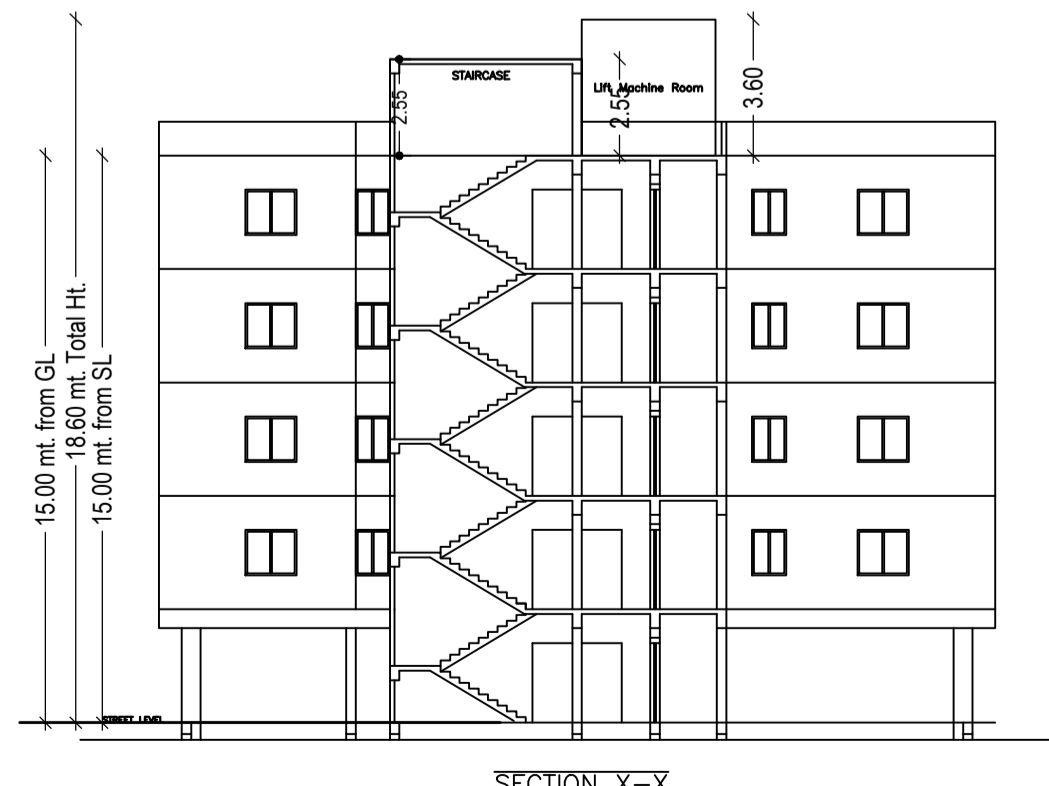

SECTION X-X
SCALE - 1:100

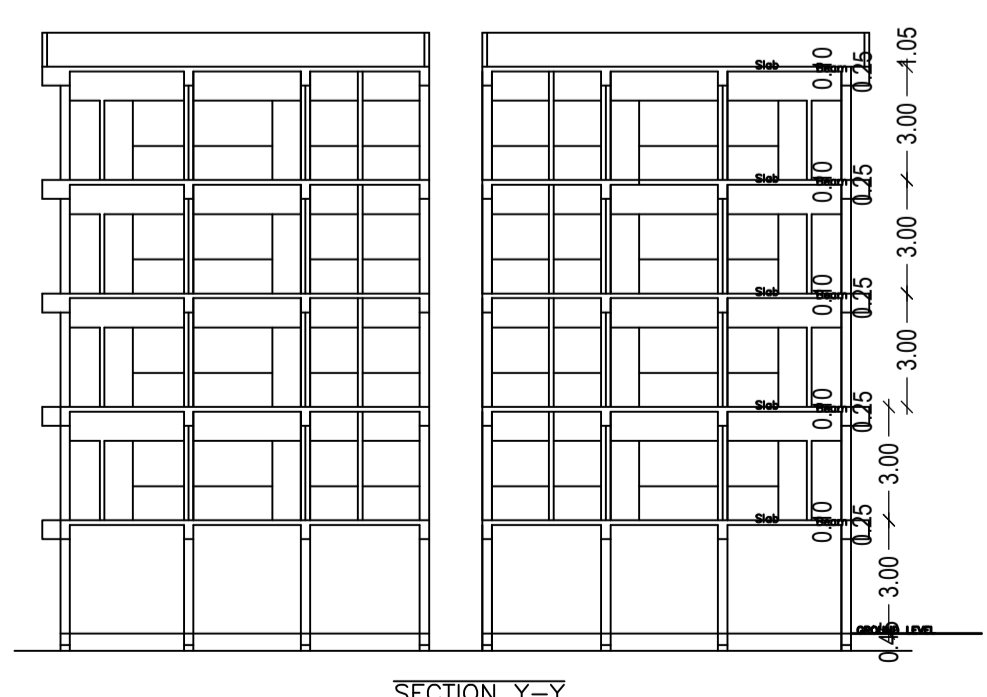

SECTION Y-Y
SCALE - 1:100

Building :C (SQUARE BUILDING BLOCK A)

Part Name	Total BUA (Sq.Mt)	Existing BUA (Sq.Mt)	Proposed BUA (Sq.Mt)	Reduction Area (Sq.Mt)	Existing FAR Area (Sq.Mt)	Proposed FAR Area (Sq.Mt)	Additional FAR Area (Sq.Mt)	SSR (Sq.Mt)	SSR (Sq.Mt)
Ground Floor	487.74	0.00	487.74	0.00	488.48	0.00	19.72	19.26	19.26
1st Floor	487.74	0.00	487.74	0.00	488.48	0.00	484.20	484.20	484.20
2nd Floor	487.74	0.00	487.74	0.00	488.48	0.00	484.20	484.20	484.20
3rd Floor	487.74	0.00	487.74	0.00	488.48	0.00	484.20	484.20	484.20
4th Floor	488.30	0.00	488.30	0.00	0.00	0.00	481.76	481.76	0.00
Total	1941.00	0.00	1941.00	0.00	1941.00	0.00	1941.00	1941.00	0.00
Total	1941.00	0.00	1941.00	0.00	1941.00	0.00	1941.00	1941.00	0.00

LTP NAME AND SIGNATURE ASHWINI KUMAR SAHU LNP/ENG/0005/2017	STRUCTURAL ENG'S NAME AND SIGNATURE	BUILDER NAME AND SIGNATURE	DIGITAL SIGNATURE
---	-------------------------------------	----------------------------	-------------------

Proposal Basic Information	
Proposal File No.	LNP/BP/0026/W07/2023
Owner Name	HINDALCO INDUSTRIES LIMITED MINES DIVISION
Khata No	34/112
Plot No	258 & 259
Village Name	Nadia
Use	Residential
SubUse	ResiComm Bldg

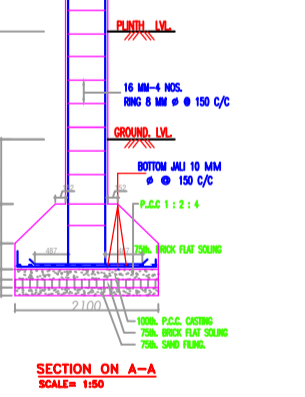
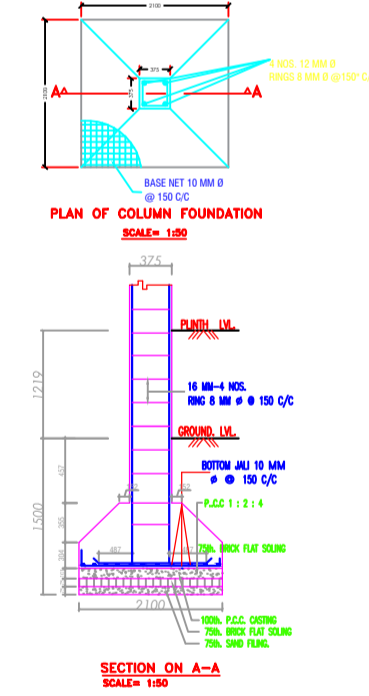
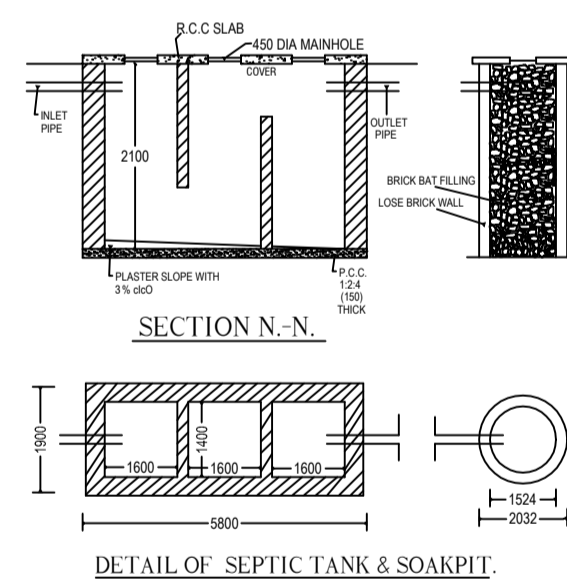
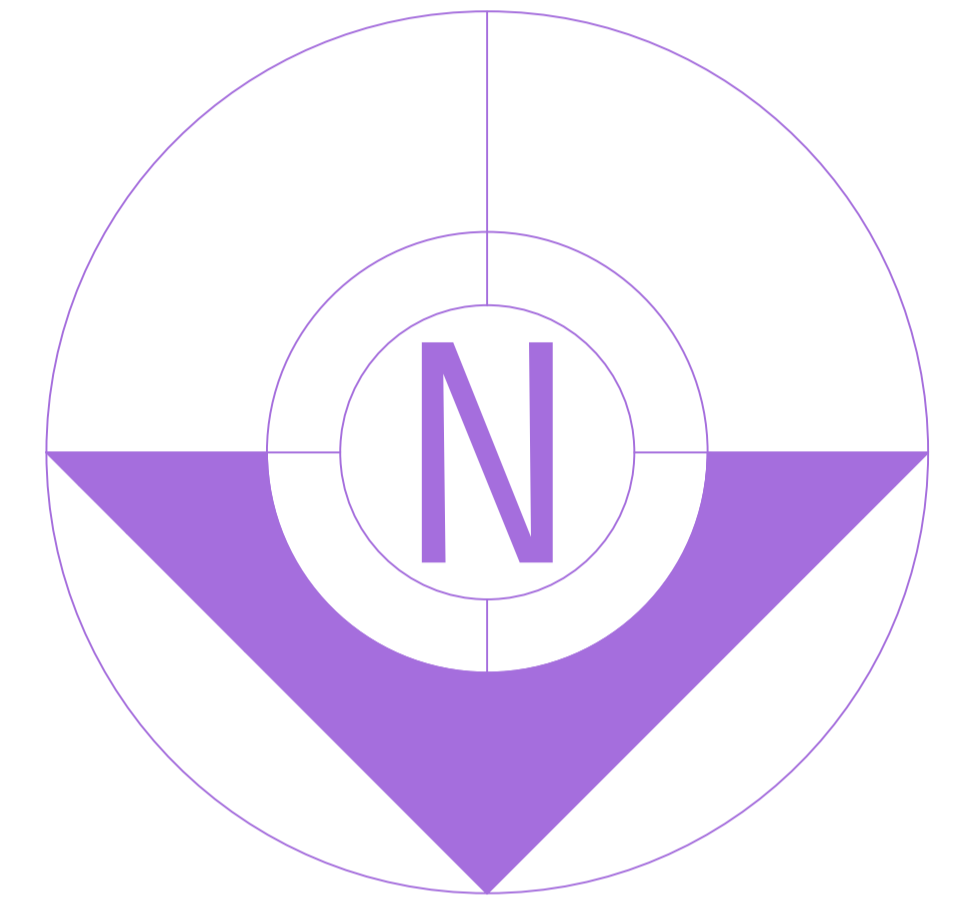
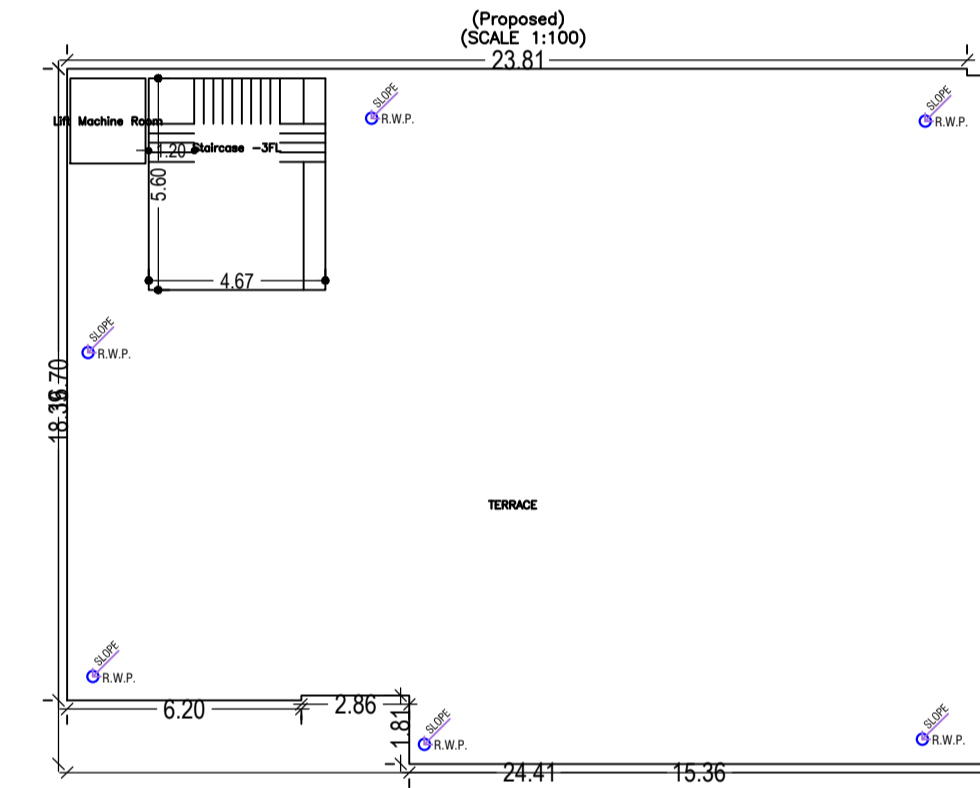
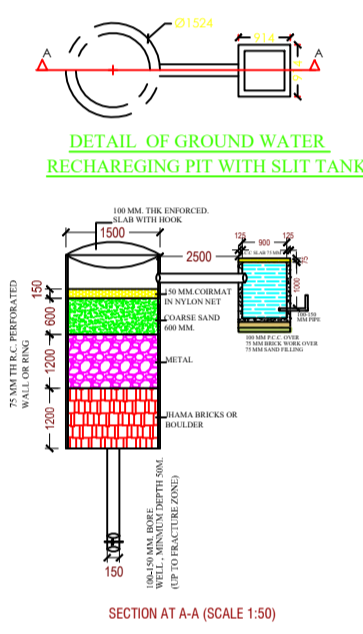
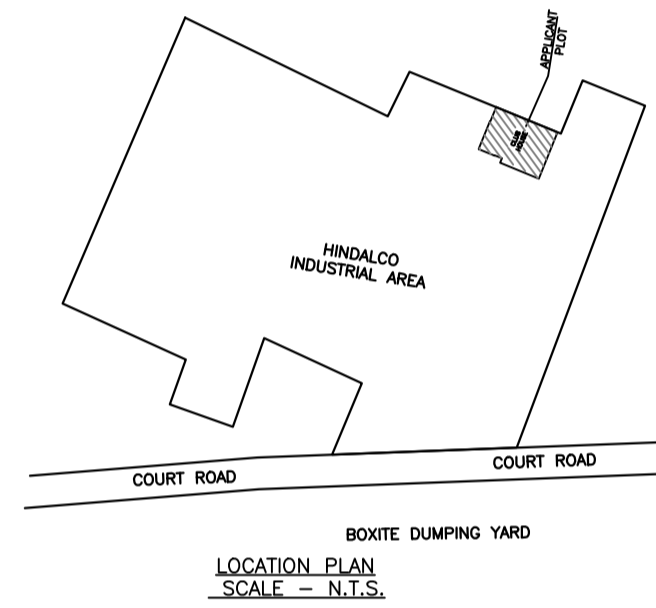
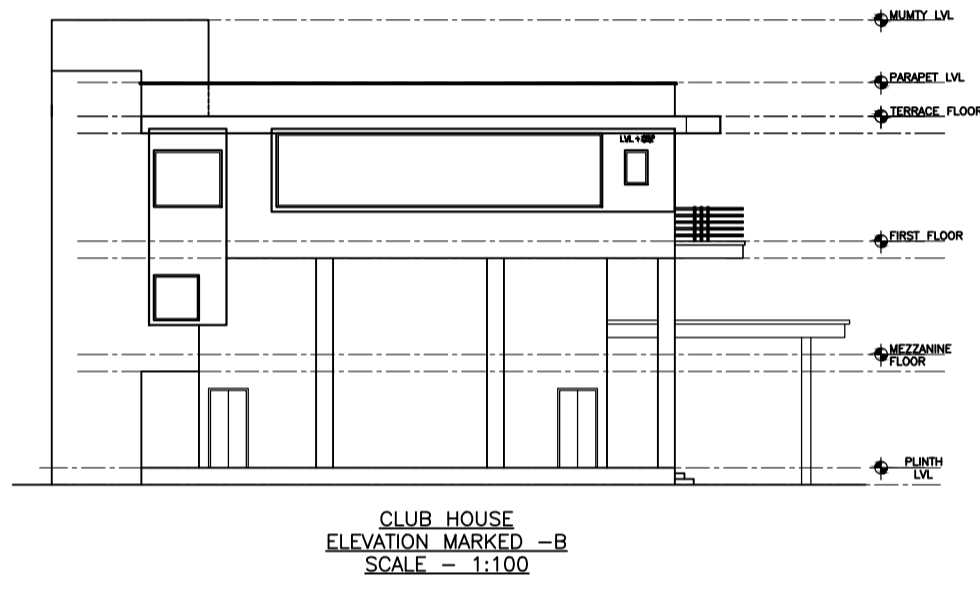
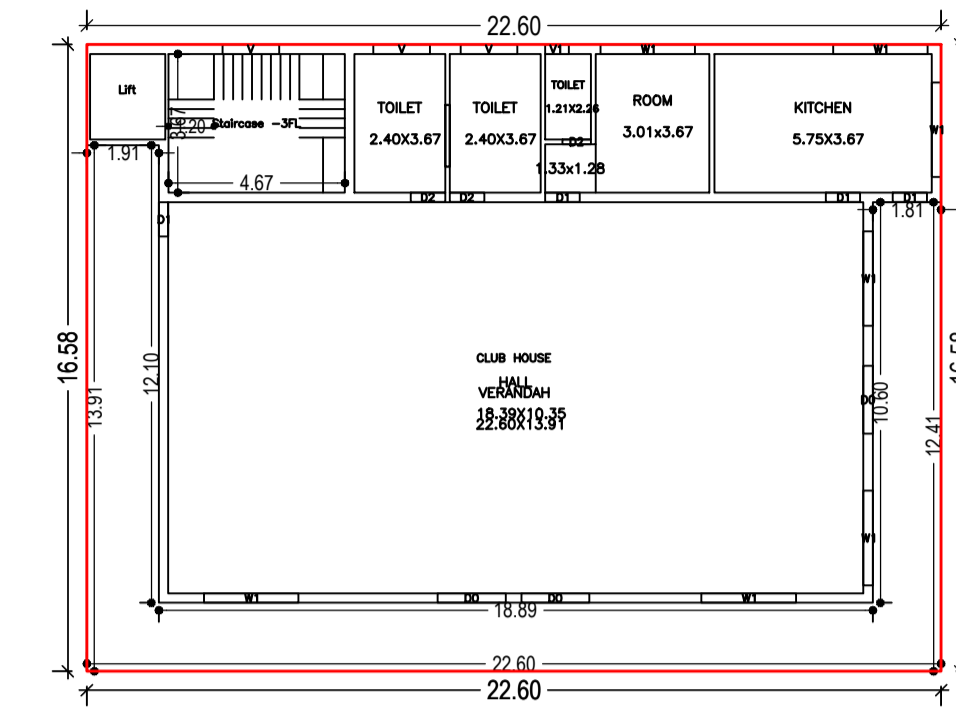
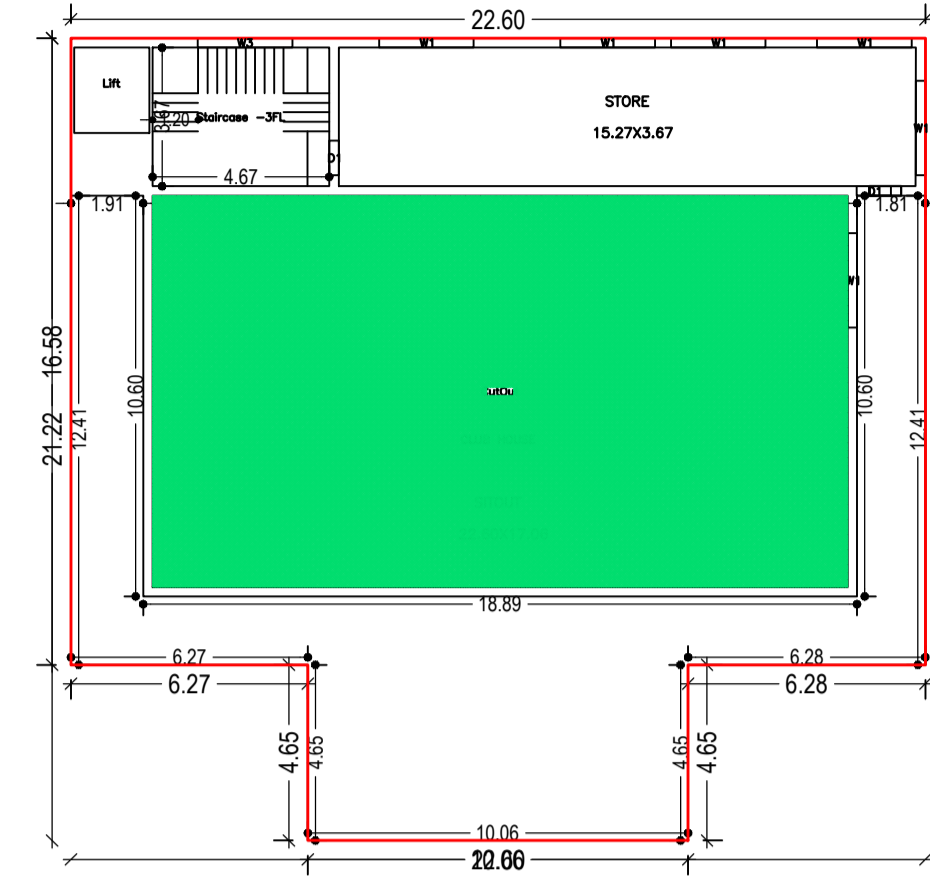
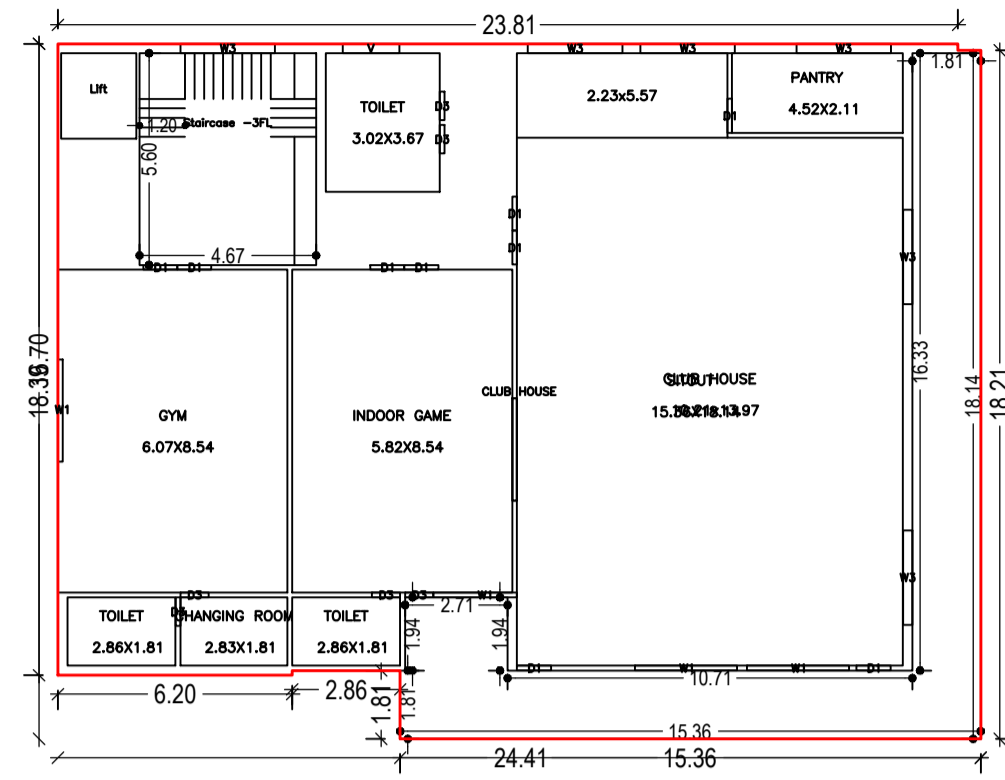

Unit/BUA Table for Building :D (CLUB HOUSE)

FLOOR	Name	Unit/BUA Type	Unit/BUA Area (Sq.M)	Carpet Area	No. of Rooms	No. of Bathrooms
GROUND FLOOR	CLUB HOUSE OFFICE	OFFICE	438.88	438.84	1	1
FIRST FLOOR	CLUB HOUSE OFFICE	OFFICE	238.97	238.96	2	1
TERRACE FLOOR	CLUB HOUSE OFFICE	OFFICE	238.94	238.94	1	1
TERRACE FLOOR	CLUB HOUSE OFFICE	OFFICE	155.42	155.42	1	1

SCHEDULE OF DOOR:

BUILDING NAME	NAME	LENGTH	HEIGHT	NO. OF
CLUB HOUSE	DOOR	2.10	2.10	05
CLUB HOUSE	DOOR	1.75	2.10	05
CLUB HOUSE	DOOR	1.75	2.10	05
CLUB HOUSE	DOOR	2.10	2.10	05
CLUB HOUSE	DOOR	1.75	2.10	05
CLUB HOUSE	DOOR	1.75	2.10	05
CLUB HOUSE	DOOR	1.75	2.10	05

SCHEDULE OF WINDOW/VENTILATION:

BUILDING NAME	NAME	LENGTH	HEIGHT	NO. OF
CLUB HOUSE	WINDOW	2.10	2.10	05
CLUB HOUSE	WINDOW	1.75	2.10	05
CLUB HOUSE	WINDOW	1.75	2.10	05
CLUB HOUSE	WINDOW	2.10	2.10	05
CLUB HOUSE	WINDOW	1.75	2.10	05
CLUB HOUSE	WINDOW	1.75	2.10	05
CLUB HOUSE	WINDOW	1.75	2.10	05

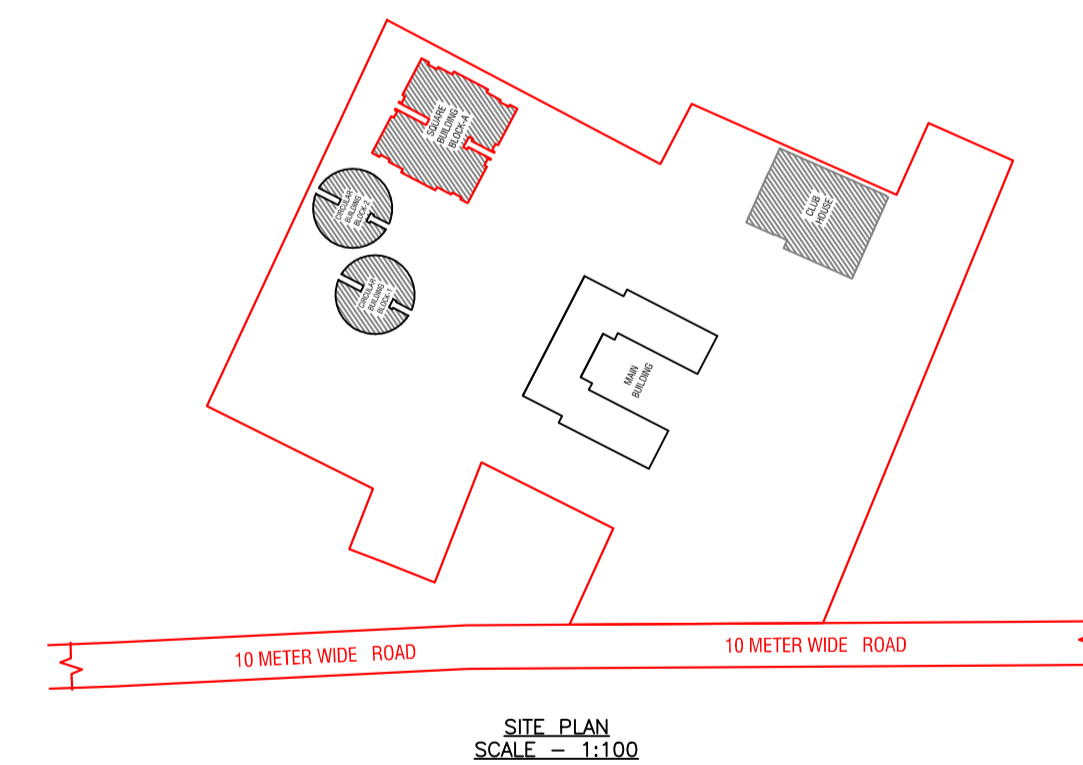

Building :D (CLUB HOUSE)

Floor Name	Area (Sq.M)	Volume (Cu.M)	Weight (Kilograms)	Volume (Cu.M)	Weight (Kilograms)	Total Consumed Area (Sq.M)	Total Consumed Volume (Cu.M)	Total Consumed Weight (Kilograms)
Ground Floor	347.79	650	334.32	650	334.32	347.79	650	334.32
First Floor	471.91	892.84	459.27	892.84	459.27	829.76	1542.84	793.59
Terrace Floor	433.19	820	433.19	820	433.19	433.19	820	433.19
Terrace Floor	9.00	17.10	9.00	17.10	9.00	9.00	17.10	9.00
Total	1261.89	2380.14	1235.70	2380.14	1235.70	1261.89	2380.14	1235.70

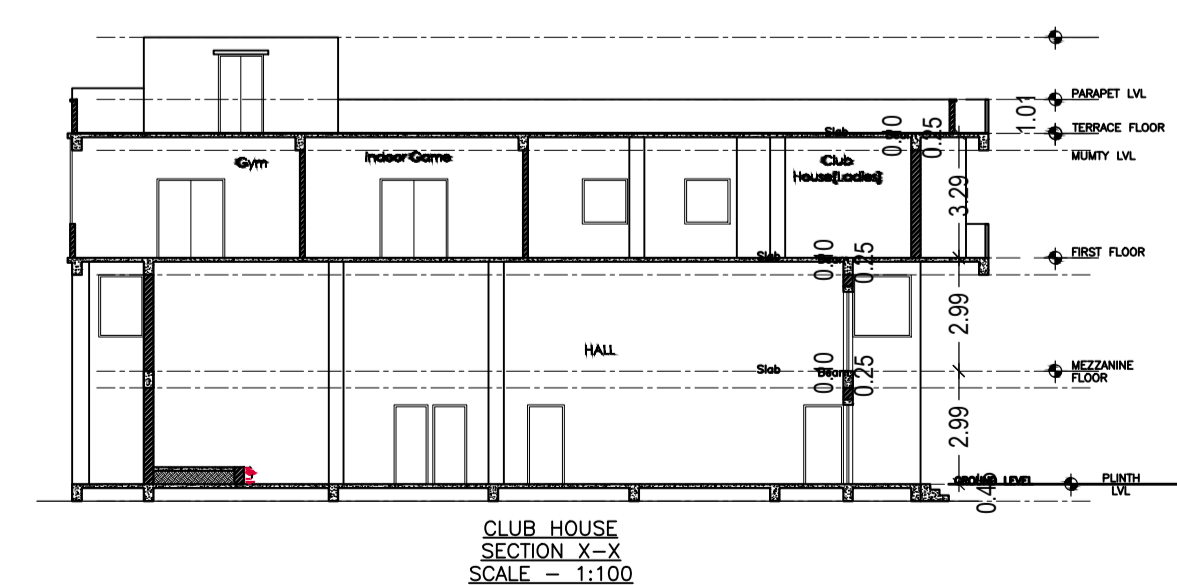
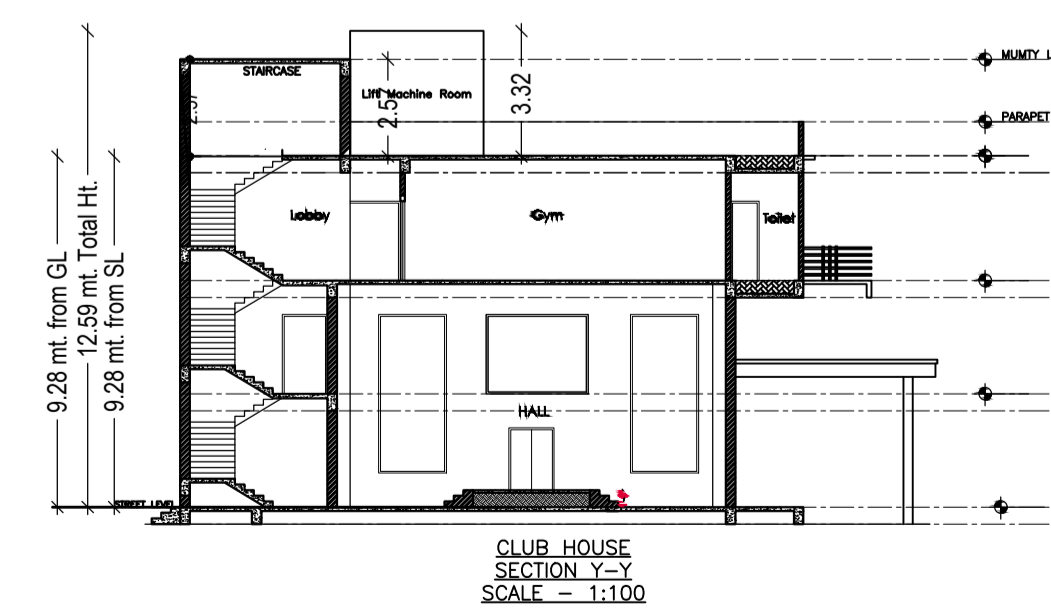

LTP NAME AND SIGNATURE	STRUCTURAL ENG'S NAME AND SIGNATURE	BUILDER NAME AND SIGNATURE	DIGITAL SIGNATURE
ASHWINI KUMAR SAHU LNP/ENG/0005/2017			

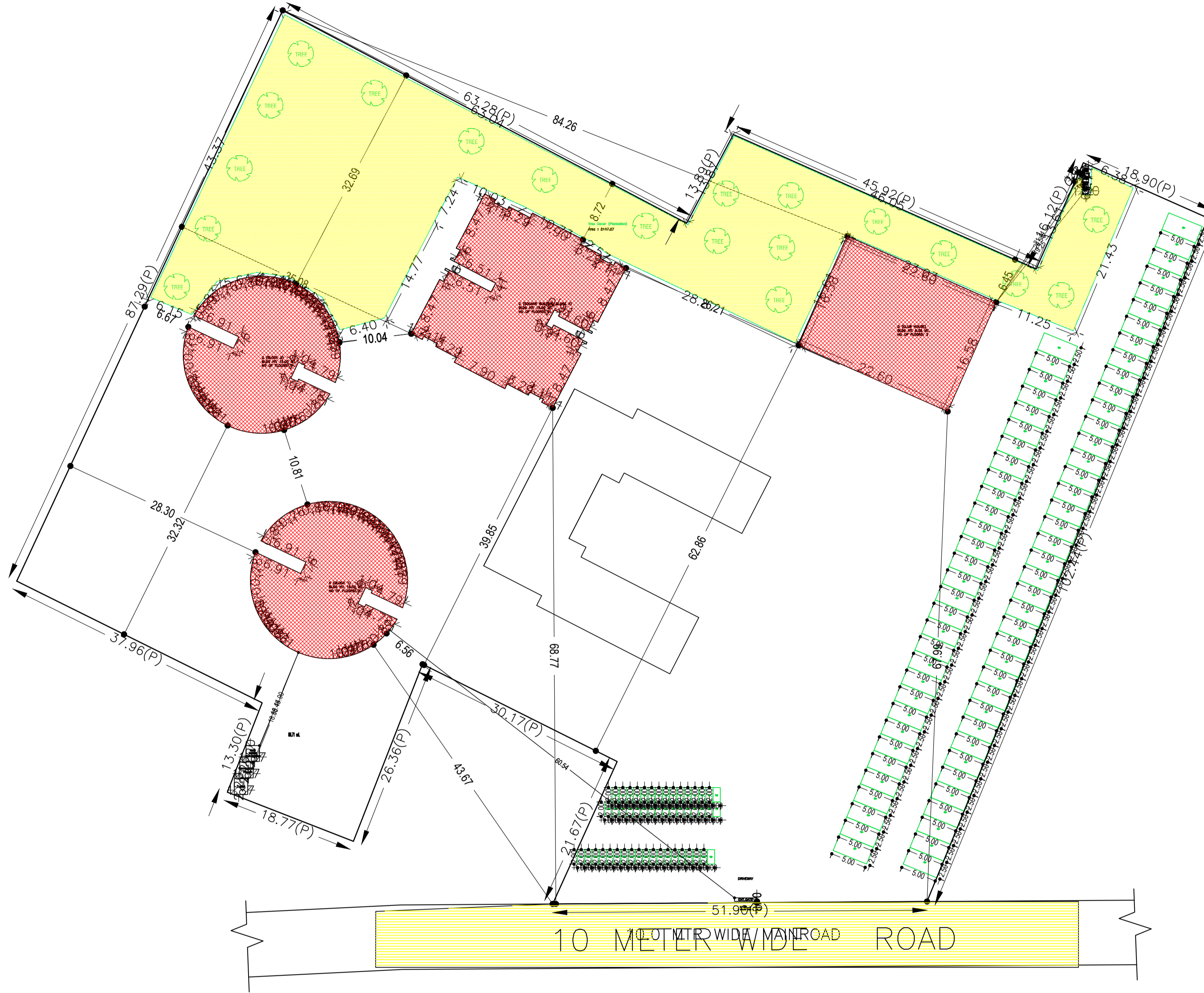
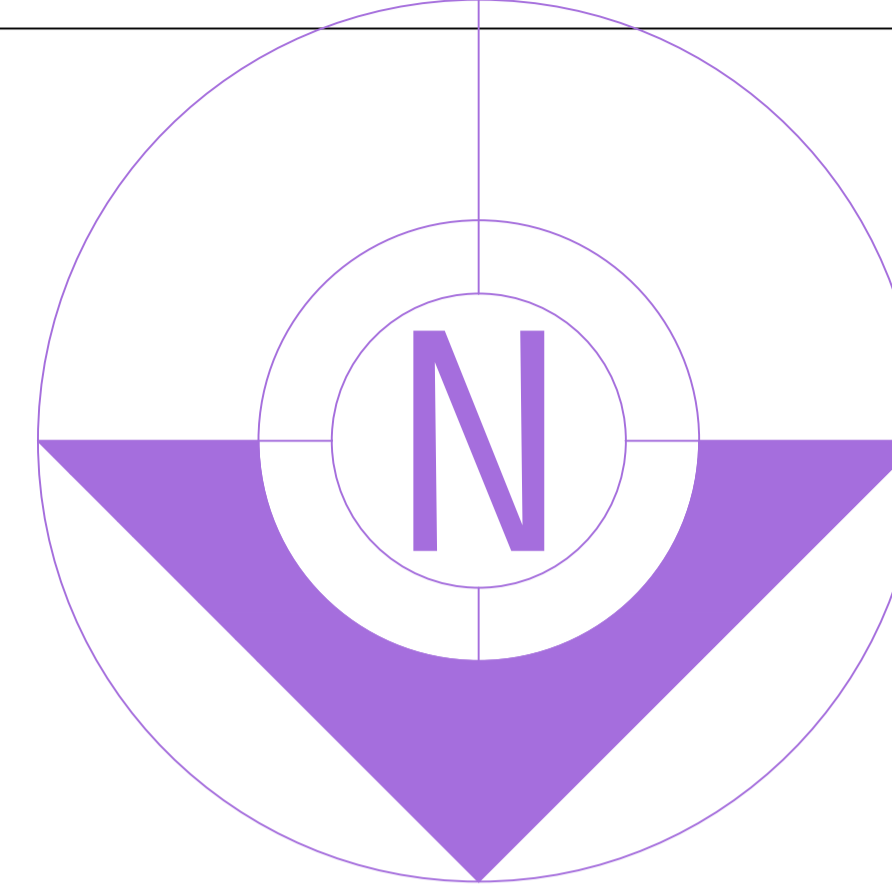

Proposal Basic Information

Proposal File No.	LNP/BP/0026/W07/2023
Owner Name	HINDALCO INDUSTRIES LIMITED MINES DIVISION
Khata No	34/112
Plot No	258 & 259
Village Name	Nadia
Use	Residential
SubUse	ResiComm Bldg

Required Parking (Table 7a)

Building Name	Type	Category	No. of Floors	Floor Area (Sq.M)	Car	Two Wheeler	Total
Block I	Residential	ResiComm	1	3000	1	1	2
Block II	Residential	ResiComm	1	3000	1	1	2
Block III	Residential	ResiComm	1	3000	1	1	2
Block IV	Residential	ResiComm	1	3000	1	1	2
Block V	Residential	ResiComm	1	3000	1	1	2
Total					5	5	10

Parking Check (Table 7b)

Vehicle Type	No.	Area	No.	Area
Car	5	90.00	5	90.00
Two Wheeler	5	10.00	5	10.00
Total	10	100.00	10	100.00

Buildingwise Floor FAR Details

Block Name	1 (BLOCK I)		2 (BLOCK II)		3 (BLOCK III)		4 (BLOCK IV)		5 (BLOCK V)		Total
	Proposed	Existing	Proposed	Existing	Proposed	Existing	Proposed	Existing	Proposed	Existing	
Block I	0.00	0.00	0.00	0.00	0.00	0.00	0.00	0.00	0.00	0.00	0.00
Block II	0.00	0.00	0.00	0.00	0.00	0.00	0.00	0.00	0.00	0.00	0.00
Block III	0.00	0.00	0.00	0.00	0.00	0.00	0.00	0.00	0.00	0.00	0.00
Block IV	0.00	0.00	0.00	0.00	0.00	0.00	0.00	0.00	0.00	0.00	0.00
Block V	0.00	0.00	0.00	0.00	0.00	0.00	0.00	0.00	0.00	0.00	0.00
Total	0.00	0.00	0.00	0.00	0.00	0.00	0.00	0.00	0.00	0.00	0.00

FAR & Tenement Details (Table 4c-1)

Block Name	No. of Units	Ground Floor Area (Sq.M)	Proposed FAR	Existing FAR	Deviations	Existing FAR	Proposed FAR	Area	Total FAR	Total FAR	Total FAR
Block I	1	2500.00	0.00	0.00	0.00	0.00	0.00	0.00	0.00	0.00	0.00
Block II	1	2500.00	0.00	0.00	0.00	0.00	0.00	0.00	0.00	0.00	0.00
Block III	1	2500.00	0.00	0.00	0.00	0.00	0.00	0.00	0.00	0.00	0.00
Block IV	1	2500.00	0.00	0.00	0.00	0.00	0.00	0.00	0.00	0.00	0.00
Block V	1	2500.00	0.00	0.00	0.00	0.00	0.00	0.00	0.00	0.00	0.00
Total	5	12500.00	0.00	0.00	0.00	0.00	0.00	0.00	0.00	0.00	0.00

Building USE/SUBUSE Details

Block Name	Building Use	Building Subuse	Building Structure
Block I	Residential	ResiComm Bldg	Non-Highrise
Block II	Residential	ResiComm Bldg	Non-Highrise
Block III	Residential	ResiComm Bldg	Non-Highrise
Block IV	Residential	ResiComm Bldg	Non-Highrise
Block V	Residential	ResiComm Bldg	Non-Highrise

PROJECT TITLE	HINDALCO INDUSTRIES LIMITED MINES DIVISION
PROJECT NO.	LNP/ENG/0005/2017
PROJECT DATE	04-09-2023
PROJECT LOCATION	Plot No. 258 & 259, Nadia
PROJECT OWNER	HINDALCO INDUSTRIES LIMITED MINES DIVISION
PROJECT MANAGER	Ashwini Kumar Sahu
PROJECT ENGINEER	Ashwini Kumar Sahu
PROJECT ARCHITECT	Ashwini Kumar Sahu
PROJECT STRUCTURAL ENGINEER	Ashwini Kumar Sahu
PROJECT ELECTRICAL ENGINEER	Ashwini Kumar Sahu
PROJECT MECHANICAL ENGINEER	Ashwini Kumar Sahu
PROJECT CIVIL ENGINEER	Ashwini Kumar Sahu
PROJECT LANDSCAPE ARCHITECT	Ashwini Kumar Sahu
PROJECT SOIL MECHANICAL ENGINEER	Ashwini Kumar Sahu
PROJECT ENVIRONMENTAL ENGINEER	Ashwini Kumar Sahu
PROJECT SAFETY ENGINEER	Ashwini Kumar Sahu
PROJECT FIRE ENGINEER	Ashwini Kumar Sahu
PROJECT HEALTH ENGINEER	Ashwini Kumar Sahu
PROJECT NUISANCE ENGINEER	Ashwini Kumar Sahu
PROJECT VIBRATION ENGINEER	Ashwini Kumar Sahu
PROJECT ACoustic ENGINEER	Ashwini Kumar Sahu
PROJECT AIR POLLUTION ENGINEER	Ashwini Kumar Sahu
PROJECT WATER POLLUTION ENGINEER	Ashwini Kumar Sahu
PROJECT SOIL POLLUTION ENGINEER	Ashwini Kumar Sahu
PROJECT CLIMATE ENGINEER	Ashwini Kumar Sahu
PROJECT ENERGY ENGINEER	Ashwini Kumar Sahu
PROJECT TRANSPORT ENGINEER	Ashwini Kumar Sahu
PROJECT TELECOMMUNICATIONS ENGINEER	Ashwini Kumar Sahu
PROJECT SPECIAL ENGINEER	Ashwini Kumar Sahu

SITE PLAN

COLOR INDEX	
BOUNDARY	Red
PROPOSED CONSTRUCTION	Green
EXISTING CONSTRUCTION	Yellow
ROAD WITHINING AREA	Blue
EXISTING (To be retained)	Grey
EXISTING (To be demolished)	Black

LTP NAME AND SIGNATURE	STRUCTURAL ENG'S NAME AND SIGNATURE	BUILDER NAME AND SIGNATURE	DIGITAL SIGNATURE
ASHWINI KUMAR SAHU LNP/ENG/0005/2017			