

Project Title : PARMESHWAR ORAON

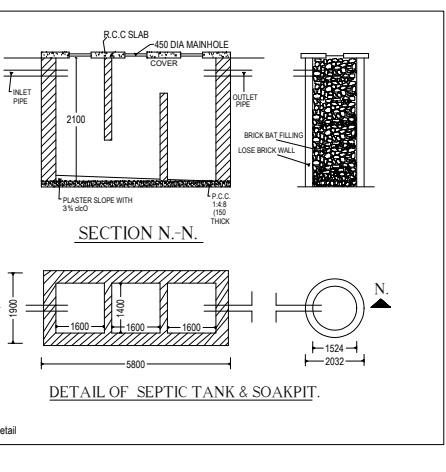
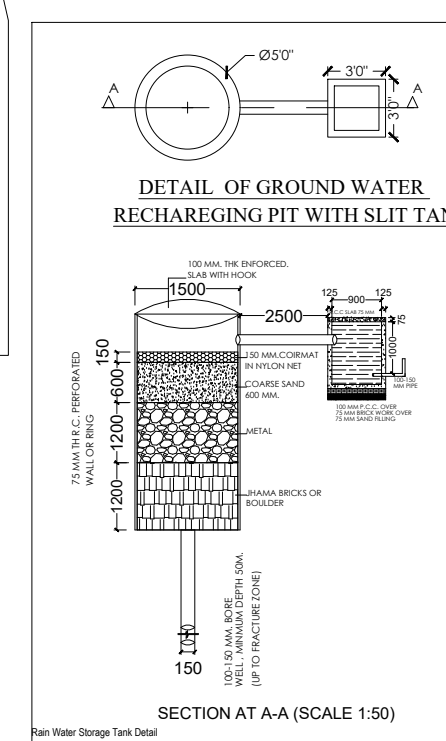
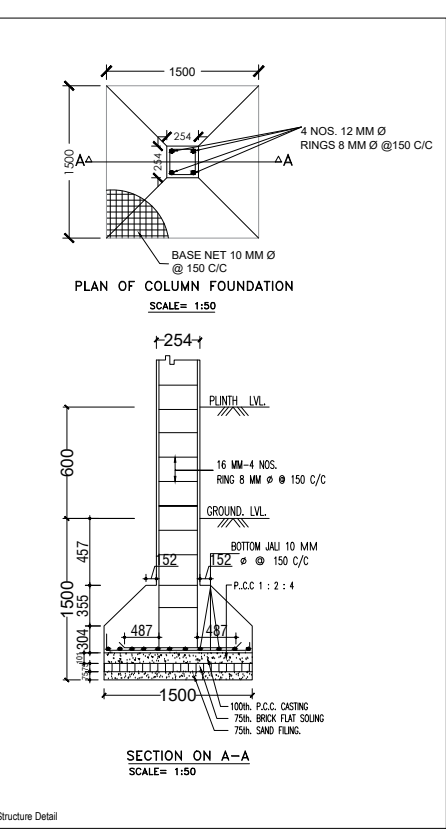
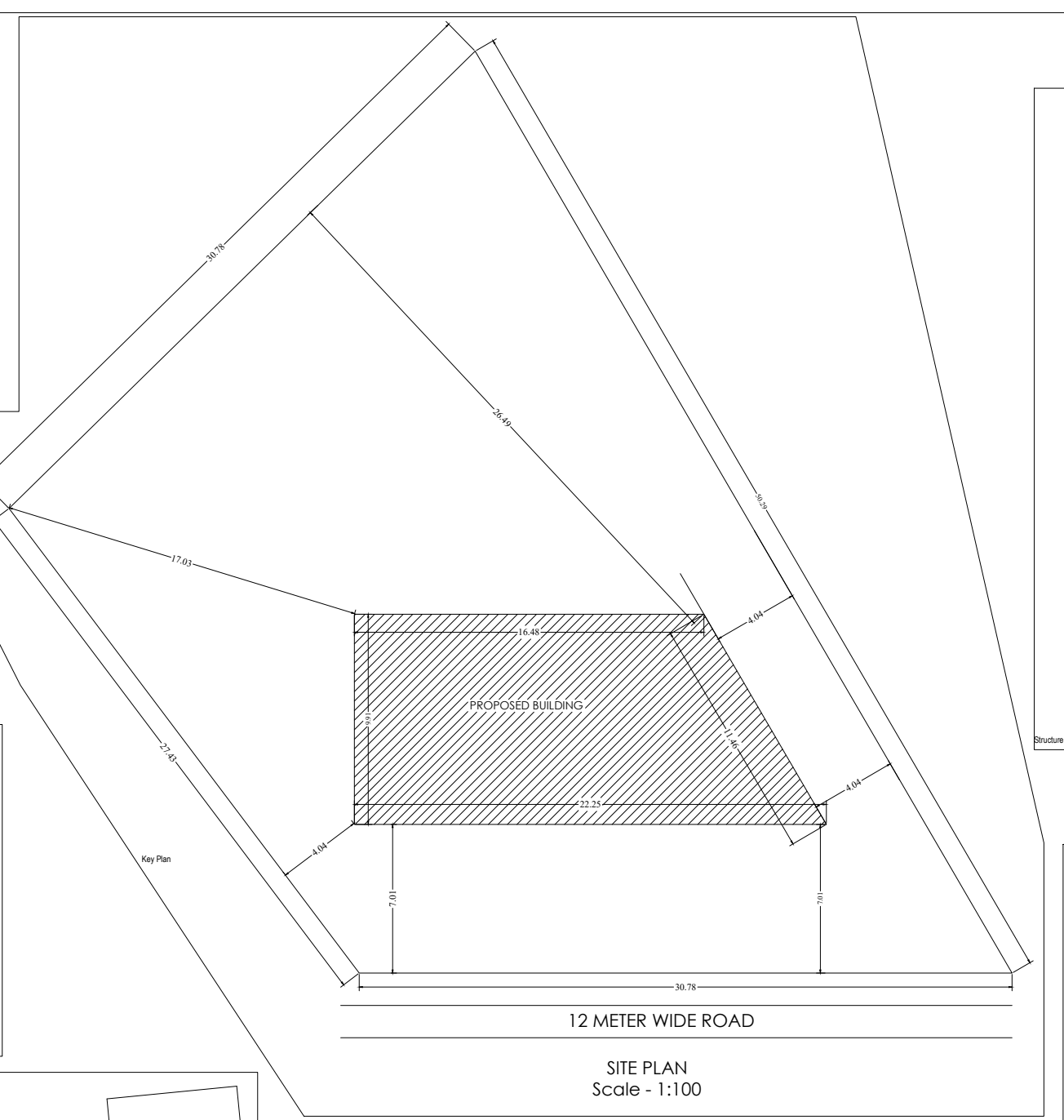
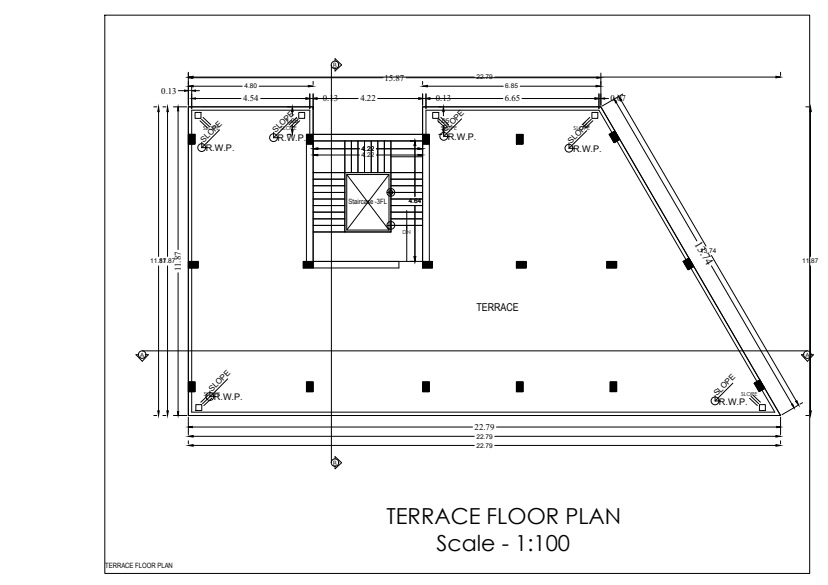
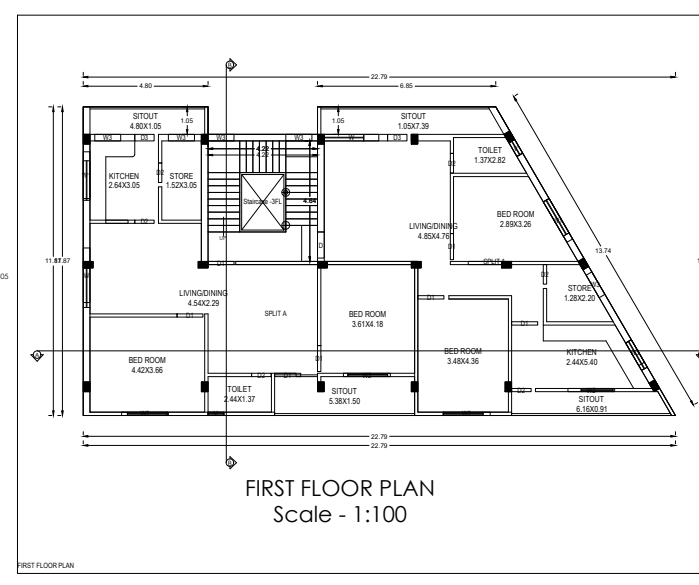
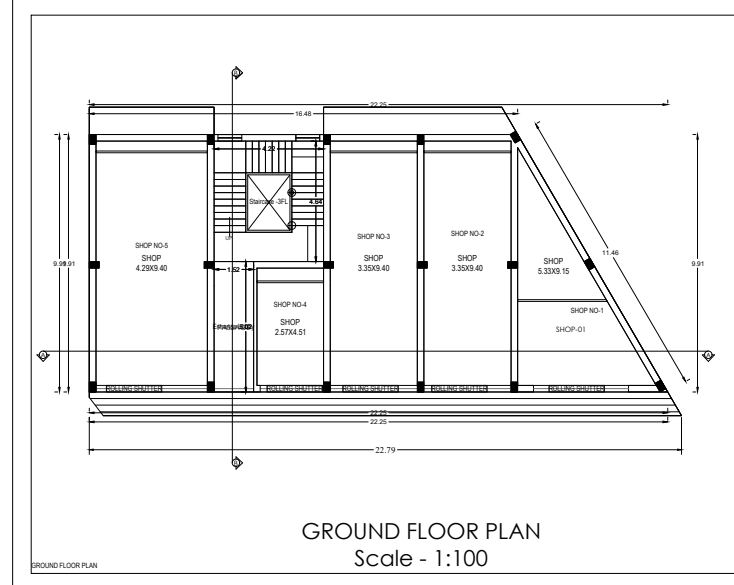
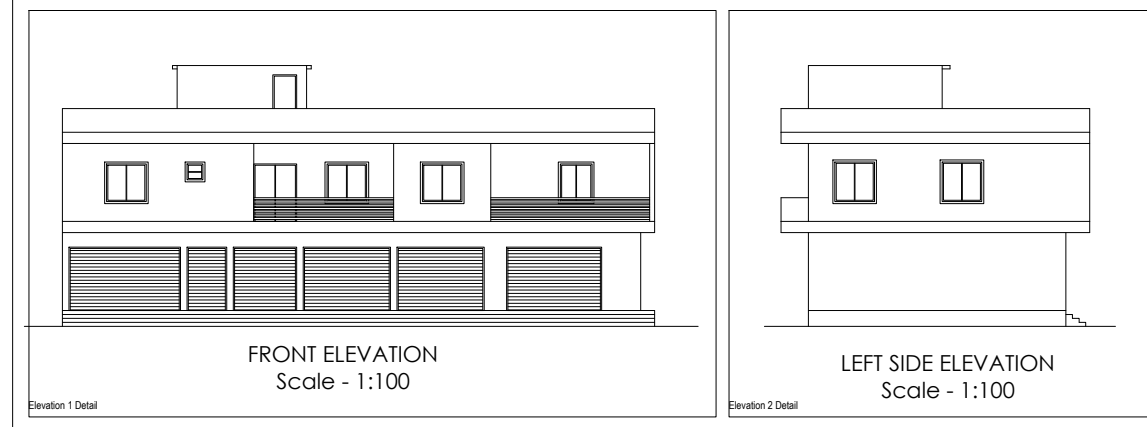
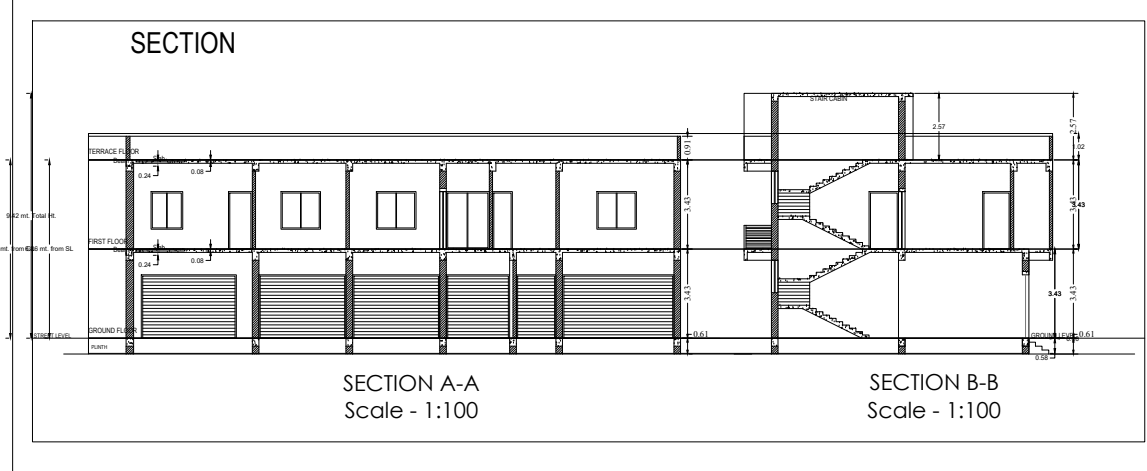
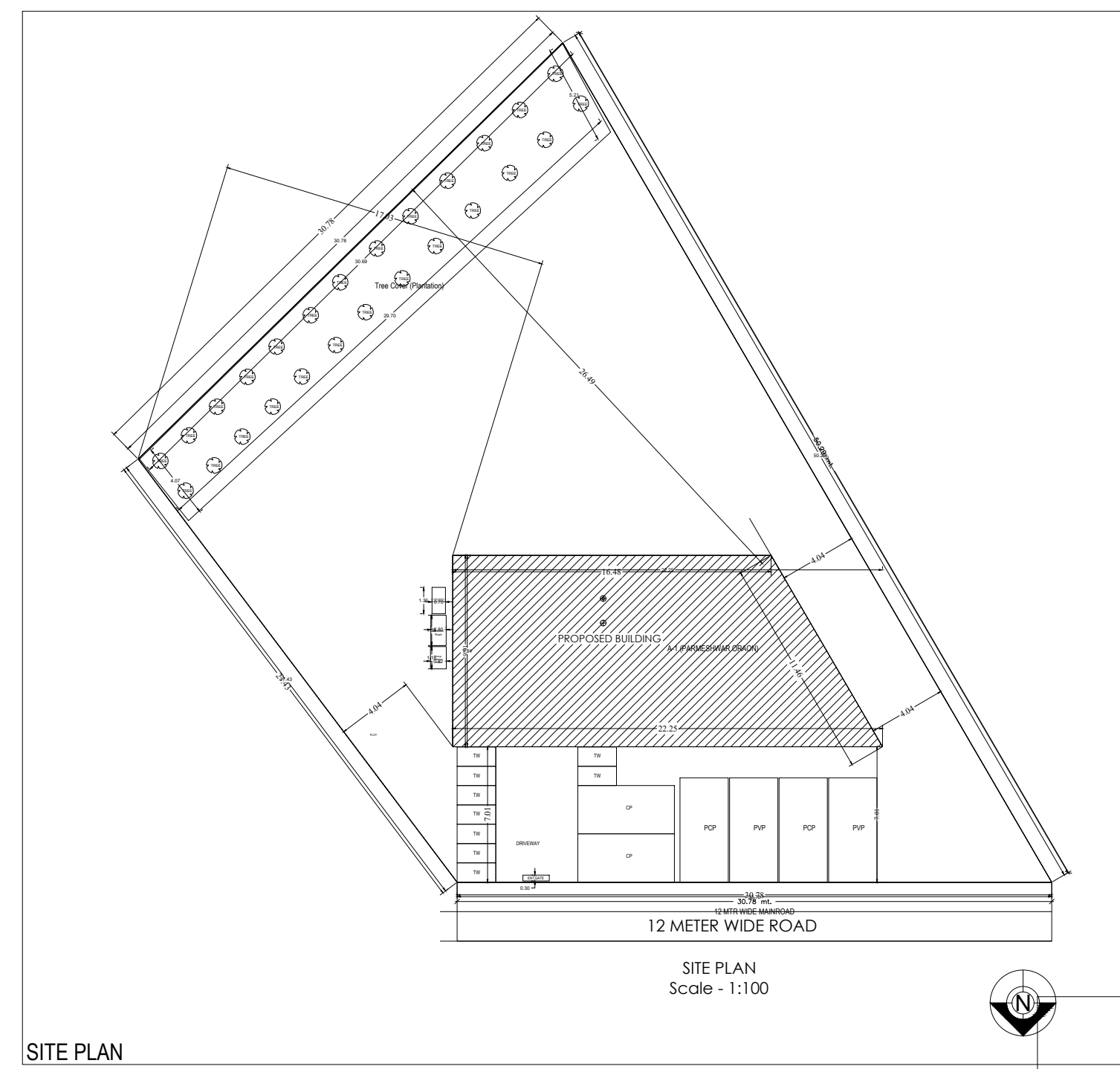

General notes

ALL DIMENSIONS ARE IN MILLIMETERS UNLESS OTHERWISE STATED.
NO DIMENSION IS TO BE SCALED OFF THE DRAWING.
DRAWINGS TO BE READ IN CONJUNCTION WITH ALL RELEVANT DRAWINGS & SPECIFICATIONS.
REFER WRITTEN DIMENSIONS ONLY.
DOORS AND WINDOW FRAME NOT TO BE FIXED ALONG WITH BRICK WORK.
INTERNAL FINISHES SHOULD BE 12MM THICK AND EXTERNAL FINISHES 20MM THICK.
FOUNDATION DEPTH UPTO GOOD SOIL.
CEMENT MORTAR OF MIX (1:1.5) FOR ENTIRE STRUCTURE AND PLASTER WORK.
SEPTIC TANK WILL BE FLUSHING SYSTEM.
ALL REINFORCEMENT SHALL BE OF TOR STEEL OF GRADE FY-415.
GRADE OF CONCRETE SHALL BE M-20.

TYPE	WIDTH	HEIGHT	SILL LVL	DESCRIPTION
D	1050	2100	NILL	SMILE SHUTTER FLOOR DOOR
D1	975	2100	NILL	**
D2	900	2100	NILL	**
D3	750	2100	NILL	**
CG	1500	2100	NILL	STEEL CHANNEL GATE
W	1500	1200	900	4 LEAF GLAZED WINDOW
W2	1200	1200	900	**
W3	900	1200	900	**
V	600	600	1500	VENTILATOR

SCHEDULE OF FINISHES

PLOT AREA AS PER DEED - 1097.85 SQMT
AREA OF GROUND FLOOR - 225.12 SQMT
AREA OF FIRST FLOOR - 225.12 SQMT
TOTAL BUILT UP AREA - 450.24 SQMT
%ag OF AREA COVERED - 20.69
TOTAL F.A.R. ACHIEVED - 0.413

PROPOSED RESIDUAL BUILDING PLAN OF PARMESHWAR ORAON, S/O LATE ANAND PAL ORAON, ON PLOT NO. 523, KHATA NO. 83, THANA NO. 197, WARD NO. - 23, AREA - 30 DECIMALS, MAUIZA - JURRYA, THANA - L OHARDAGA, DIST - L OHARDAGA - 833002, STATE - JHARKHAND

ISSUE ONLY FOR CLIENT

SCALE	DATE	SHEET NO.
1 : 100		01 OF 01

CLIENT _____ **ENGINEER / ARCHITECT** _____

REVISIONS

NO.	DESCRIPTION	DATE
1	ISSUED FOR PERMIT	15/08/2024

COLOR INDEX

NO.	DESCRIPTION	COLOR
1	CONCRETE	Grey
2	BRICK	Red
3	PLASTER	White
4	PAINT	Blue

PAVING CALCULATION

ITEM	Quantity	Unit
1	100	Sq. Mtr.
2	50	Sq. Mtr.

PERMITS & APPROVALS

NO.	DESCRIPTION	DATE
1	ISSUED FOR PERMIT	15/08/2024

Building a PARMESHWAR ORAON

Sl. No.	Particulars	Quantity	Unit	Rate	Amount
1	Excavation	100	Sq. Mtr.	100	10000
2	Concrete	50	Sq. Mtr.	200	10000
3	Brick	1000	Sq. Mtr.	100	100000
4	Plaster	100	Sq. Mtr.	100	10000
5	Paint	100	Sq. Mtr.	100	10000
6	Other	100	Sq. Mtr.	100	10000
Total					240000

SCHEDULE OF JOINTS

Sl. No.	Particulars	Quantity	Unit	Rate	Amount
1	Excavation	100	Sq. Mtr.	100	10000
2	Concrete	50	Sq. Mtr.	200	10000
3	Brick	1000	Sq. Mtr.	100	100000
4	Plaster	100	Sq. Mtr.	100	10000
5	Paint	100	Sq. Mtr.	100	10000
6	Other	100	Sq. Mtr.	100	10000
Total					240000

UNDER TABLE TO BUILDING a PARMESHWAR ORAON

Sl. No.	Particulars	Quantity	Unit	Rate	Amount
1	Excavation	100	Sq. Mtr.	100	10000
2	Concrete	50	Sq. Mtr.	200	10000
3	Brick	1000	Sq. Mtr.	100	100000
4	Plaster	100	Sq. Mtr.	100	10000
5	Paint	100	Sq. Mtr.	100	10000
6	Other	100	Sq. Mtr.	100	10000
Total					240000