

Proposal Basic Information	
Proposal File No.	LNP/BP/0008/W20/2024
Owner Name	ANITA DEVI
Khata No	158
Plot No	12/2244/2501
Village Name	Lohardaga
Use	Residential
SubUse	Bungalow/ Dwelling / Non Apartment

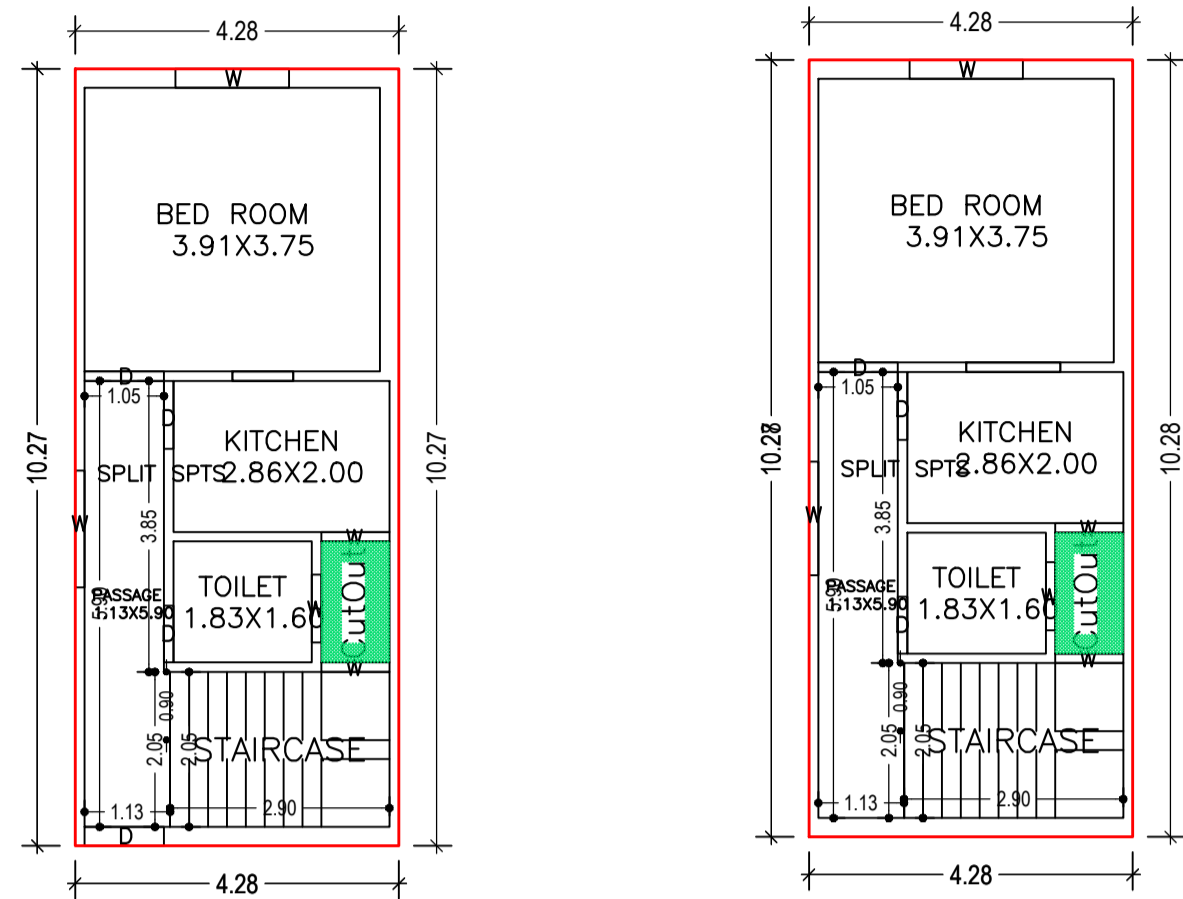

GROUND FLOOR PLAN (Proposed) (SCALE 1:100)

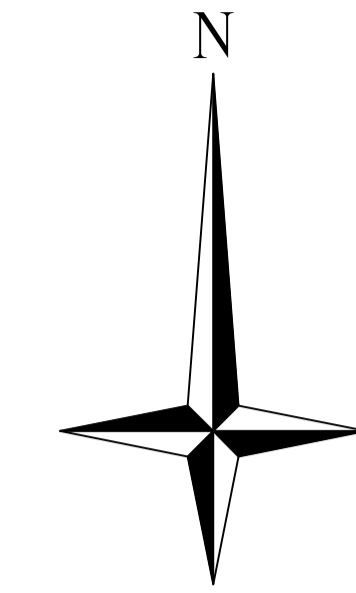
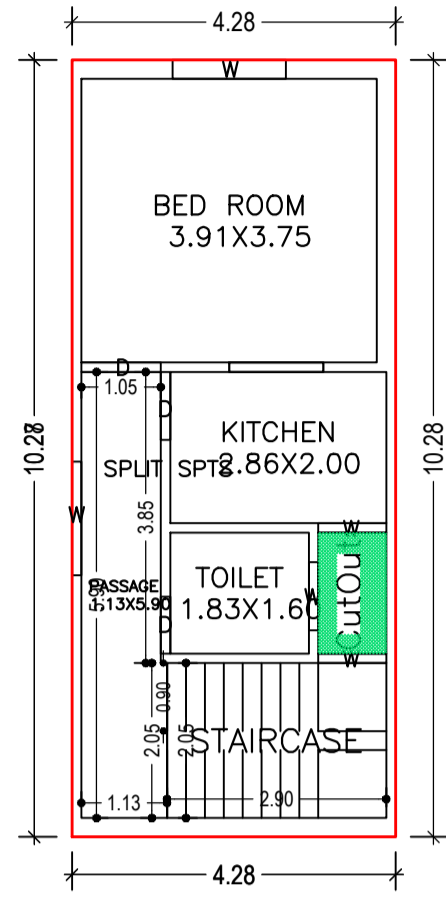

FIRST FLOOR PLAN (Proposed) (SCALE 1:100)

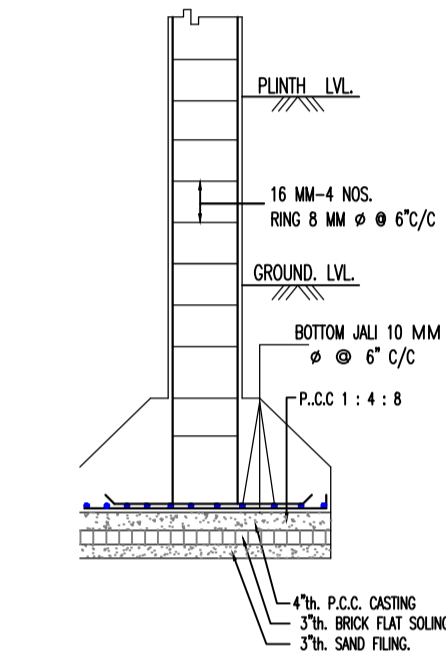
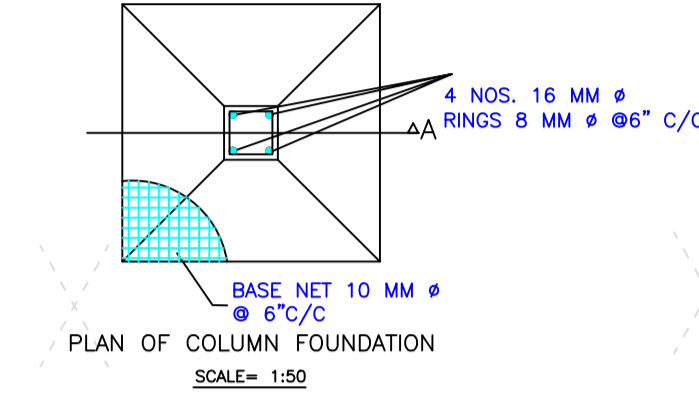
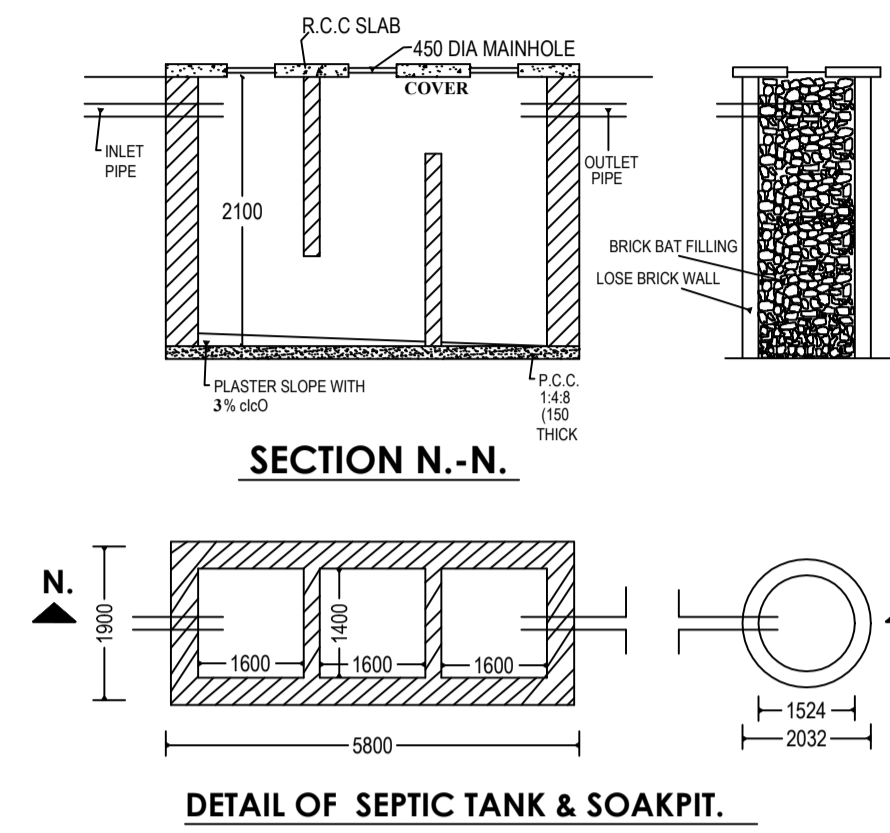
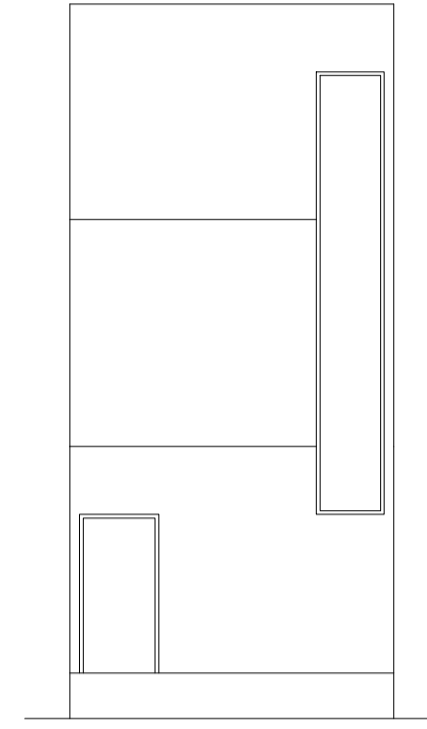

UnitBUA Table for Building :ABC (123)

FLOOR	Name	UnitBUA Type	UnitBUA Area	Carpet Area	No. of Rooms	No. of Tenement
GROUND FLOOR PLAN	SPLIT SPTS	FLAT	85.12	84.86	4	1
FIRST FLOOR PLAN	SPLIT SPTS	FLAT	0.00	0.00	4	0
Total:	-	-	85.12	84.86	8	1

Building :ABC (123)

Floor Name	Gross Builtup Area	Deductions From Gross BUA/Area in Sq.mt.)	Total Built Up Area (Sq.mt.)	Proposed FAR Area (Sq.mt.)	Total FAR Area (Sq.mt.)	Total Consumed Additional FAR Area (Sq.mt.)	Tnmt (No.)
Ground Floor	44.00	1.44	42.56	42.56	42.56	42.56	01
First Floor	44.00	1.44	42.56	42.56	42.56	42.56	00
Terrace Floor	0.00	0.00	0.00	0.00	0.00	0.00	00
Total :	88.00	2.88	85.12	85.12	85.12	85.12	01
Total Number of Same Buildings	1						
Total :	88.00	2.88	85.12	85.12	85.12	85.12	01

Building USE/SUBUSE Details

Building Name	Building Use	Building SubUse	Building Structure
ABC (123)	Residential	Bungalow/ Dwelling / Non Apartment	Non-Highrise

SCHEDULE OF DOOR:

BUILDING NAME	NAME	LENGTH	HEIGHT	NOS
ABC (123)	D	0.75	2.10	02
ABC (123)	D	0.90	2.10	02
ABC (123)	D	1.05	2.10	03

SCHEDULE OF WINDOW/VENTILATION:

BUILDING NAME	NAME	LENGTH	HEIGHT	NOS
ABC (123)	W	0.90	1.20	06
ABC (123)	W	1.50	1.20	03
ABC (123)	W	1.55	1.20	01

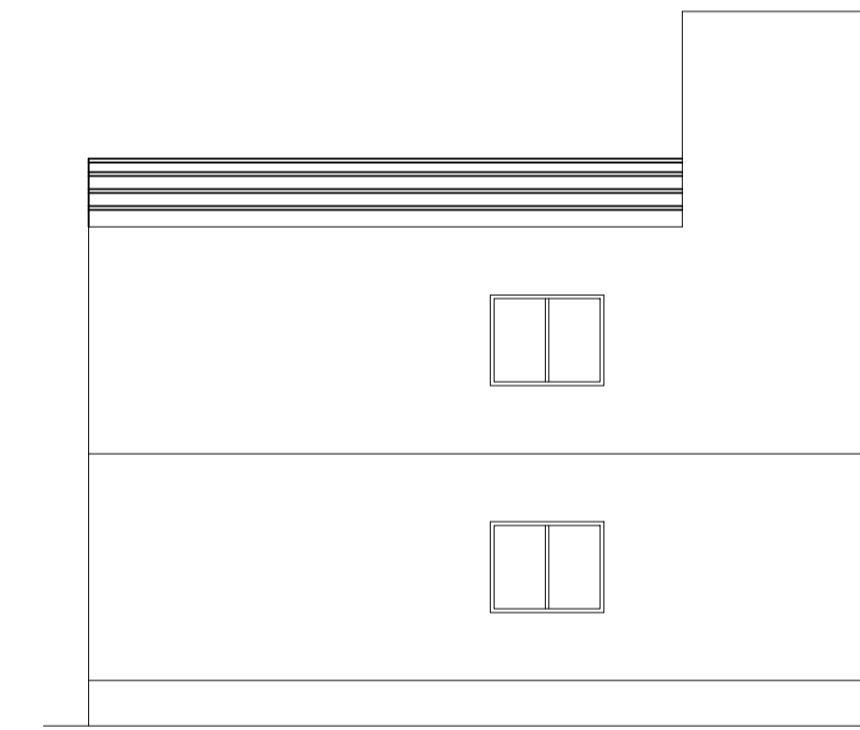
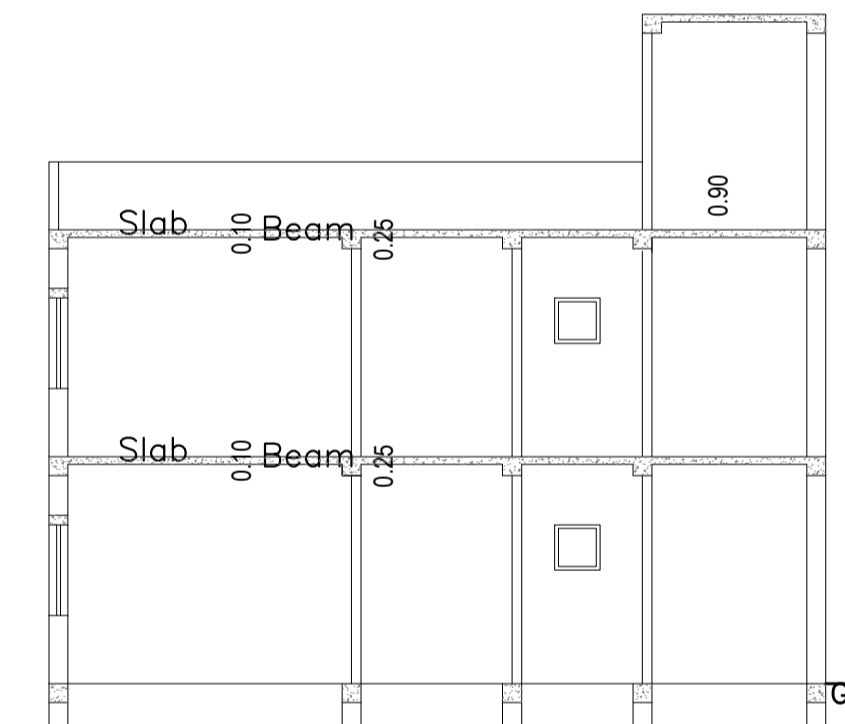
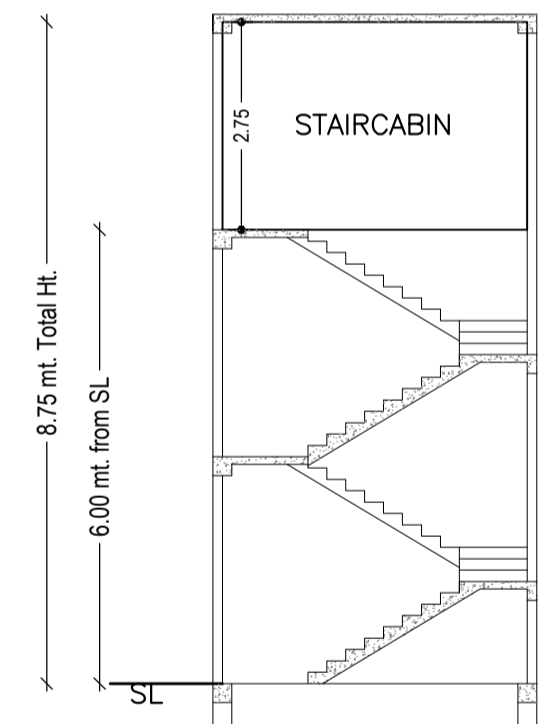

FAR & Tenement Details (Table 4c-1)

Building	No. of Same Bldg	Gross Built Up Area (Sq.mt.)	Deductions From Gross BUA/Area in Sq.mt.)	Total Built Up Area (Sq.mt.)	Proposed FAR Area (Sq.mt.)	Total FAR Area (Sq.mt.)	Total Consumed Additional FAR Area (Sq.mt.)	Tnmt (No.)
ABC (123)	1	88.00	2.88	85.12	85.12	85.12	85.12	01
Grand Total :	1	88.00	2.88	85.12	85.12	85.12	85.12	01

Buildingwise Floor FAR Details

Floor Name	Building Name		Total	
	Proposed Built Up Area (Sq.mt.)	Proposed FAR Area (Sq.mt.)	Total Proposed Built Up Area (Sq.mt.)	Total FAR Area (Sq.mt.)
Ground Floor	42.56	42.56	42.56	42.56
First Floor	42.56	42.56	42.56	42.56
Terrace Floor	0.00	0.00	0.00	0.00
Total :	85.12	85.12	85.12	85.12

COLOR INDEX	
PLOT BOUNDARY	Black
ABUTTING ROAD	Green
PROPOSED CONSTRUCTION	Red
COMMON PLOT	Yellow
ROAD WIDENING AREA	Blue
EXISTING (To be retained)	Orange
EXISTING (To be demolished)	Light Blue

AREA STATEMENT		VERSION NO.: 1.0.68
LOHARDAGA NAGAR PARISHAD		VERSION DATE: 16/10/2020
PROJECT DETAIL:		
Region: JHARKHAND URBAN	Plot Use: Residential	
LOCAL BODIES: District: LOHARDAGA	Plot SubUse: Bungalow/ Dwelling / Non Apartment	
Authority: LOHARDAGA NAGAR PARISHAD	PlotNearby/ReligiousStructure: NA	
Inward_No: LNP/BP/0008/W20/2024	Plot/SubPlot No: 12/2244/2501	
Application Type: General Proposal	North: -	
Project Type: Building Permission	South: -	
Nature of Development: New	East: -	
Location of Development Area: Old Area	West: -	
AREA DETAILS:		
AREA OF PLOT (Minimum)	(A)	77.73
Deduction for NetPlot Area		
Surrender Free of Cost		6.35
Total		6.35
NET AREA OF PLOT(Gross Plot Area - Deduction from Gross Plot area)	(A-Deductions)	71.38
Deduction for Balance Plot Area(from Gross Plot Area)		
Surrender Free of Cost		6.35
Common Plot		9.00
Total		15.35
BALANCE AREA OF PLOT(Net Plot Area - Recreational/Amenity space)	(A-Deductions)	62.38
PLOT AREA FOR COVERAGE(Net Plot Area)	(A-Deductions)	71.38
Plot Area for FAR (Net Plot Area + RoadWidening Area)	(A-Deductions)	77.73
COVERAGE CHECK		
Permissible Coverage area ( 70.00 % )		49.97
Proposed Coverage Area ( 59.62 % )		42.56
Total Prop. Coverage Area ( 59.62 % )		42.56
Balance coverage area ( 10.38 % )		7.41
FAR CHECK		
Perm. FAR Area ( 1.500 )		116.60
Total Perm. FAR area		116.60
Residential FAR		85.12
Proposed FAR Area		85.12
Total Proposed FAR Area		85.12
Consumed FAR (Factor)		1.10
Balance FAR Area		31.48
BUILT UP AREA CHECK		
Total Proposed BuiltUp Area		85.12
ARCHITECT (Regd)		
ENGINEER (Regd)		Ataul Haque
SUPERVISOR (Regd)		
OWNER (Regd)		ANITA DEVI
DEVELOPMENT AUTHORITY		LOCAL BODY

LTP NAME AND SIGNATURE	STRUCTURAL ENG'S NAME AND SIGNATURE	BUILDER NAME AND SIGNATURE	DIGITAL SIGNATURE
Ataul Haque LNP/ENG/001/2021			