

Proposal Basic Information

Proposal File No.	LNP/0022/W16/2024
Owner Name	VARUN KUMAR GUPTA
Khata No	M/S
Plot No	M/S 1128
Village Name	Lohardaga
Use	Residential
SubUse	Bungalow/ Dwelling / Non Apartment

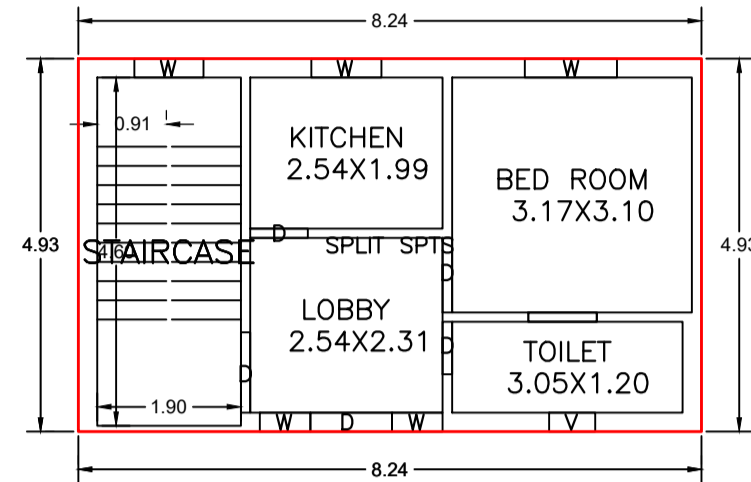

GROUND FLOOR PLAN  
(Proposed)  
(SCALE 1:100)

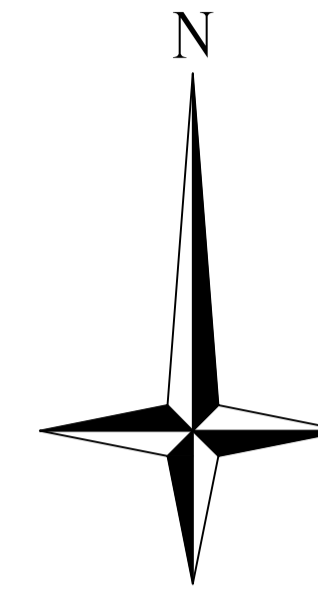
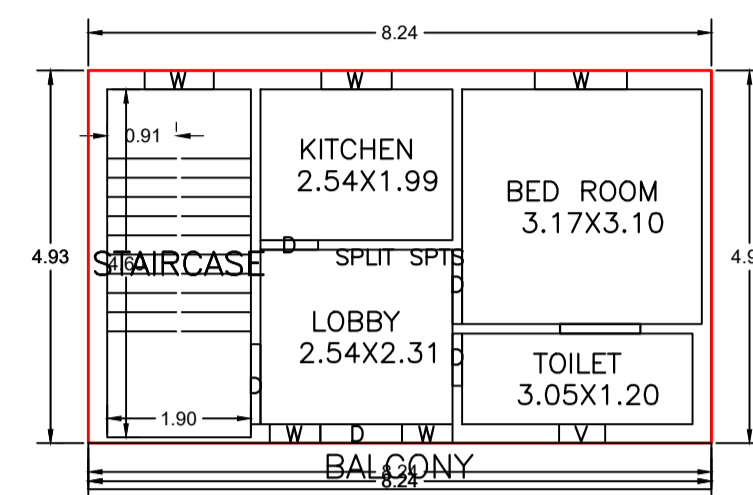

FIRST FLOOR PLAN  
(Proposed)  
(SCALE 1:100)

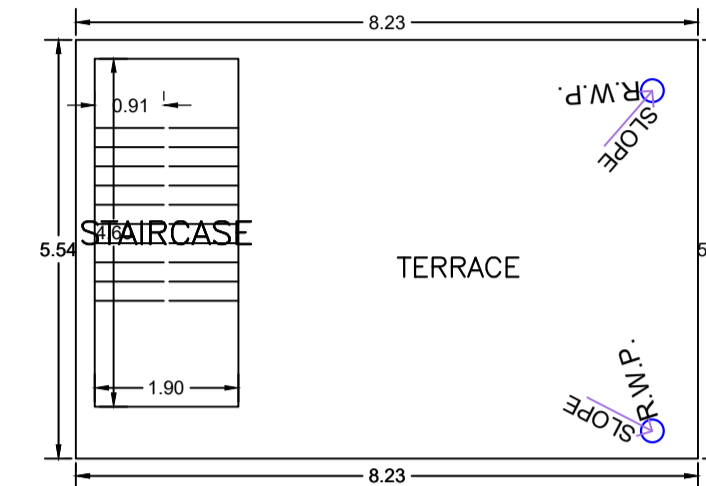

TERRACE FLOOR PLAN  
(SCALE 1:100)

Balcony Calculations Table

FLOOR	SIZE	AREA	TOTAL AREA
FIRST FLOOR PLAN	0.61 X 8.24 X 1 X 1	5.03	5.03
Total	-	-	5.03

UnitBUA Table for Building :ABC (123)

FLOOR	Name	UnitBUA Type	UnitBUA Area	Carpet Area	No. of Rooms	No. of Tenement
GROUND FLOOR PLAN	SPLIT SPTS	FLAT	86.29	81.02	4	1
FIRST FLOOR PLAN	SPLIT SPTS	FLAT	0.00	0.00	4	0
Total:	-	-	86.29	81.02	8	1

Building :ABC (123)

Floor Name	Total Built Up Area (Sq.mt.)	Deductions (Area in Sq.mt.)	Proposed FAR Area (Sq.mt.)	Total FAR Area (Sq.mt.)	Total Consumed Additional FAR Area (Sq.mt.)	Trmt (No.)
Ground Floor	40.63	0.00	40.63	40.63	40.63	01
First Floor	45.65	2.51	43.14	43.14	43.14	00
Terrace Floor	0.00	0.00	0.00	0.00	0.00	00
Total :	86.28	2.51	83.77	83.77	83.77	01
Total Number of Same Buildings	1					
Total :	86.28	2.51	83.77	83.77	83.77	01

SCHEDULE OF DOOR:

BUILDING NAME	NAME	LENGTH	HEIGHT	NOS
ABC (123)	D	0.69	2.10	02
ABC (123)	D	0.76	2.10	02
ABC (123)	D	0.98	2.10	02
ABC (123)	D	1.06	2.10	02
ABC (123)	D	1.08	2.10	02

SCHEDULE OF WINDOW/VENTILATION:

BUILDING NAME	NAME	LENGTH	HEIGHT	NOS
ABC (123)	V	0.61	1.20	02
ABC (123)	W	0.67	1.20	04
ABC (123)	W	0.91	1.20	02
ABC (123)	W	0.93	1.20	02
ABC (123)	W	1.22	1.20	02

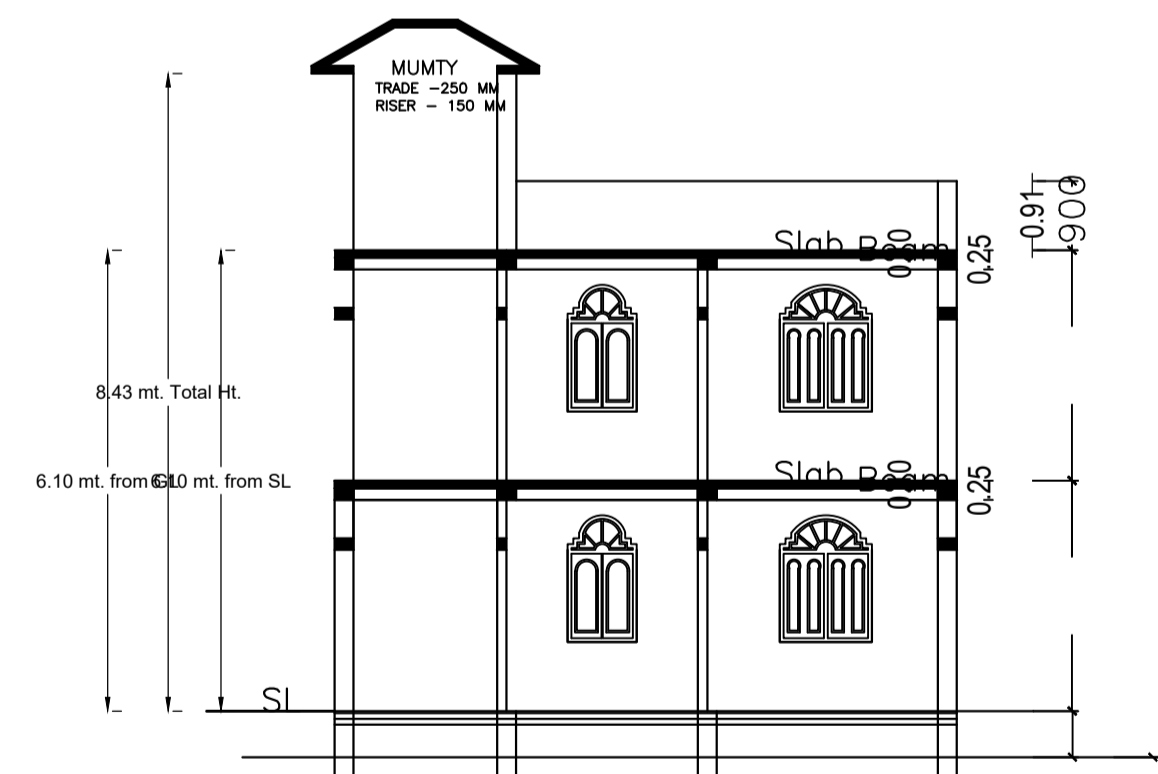

SECTION AT (X-X)  
SCALE :- 1"=100

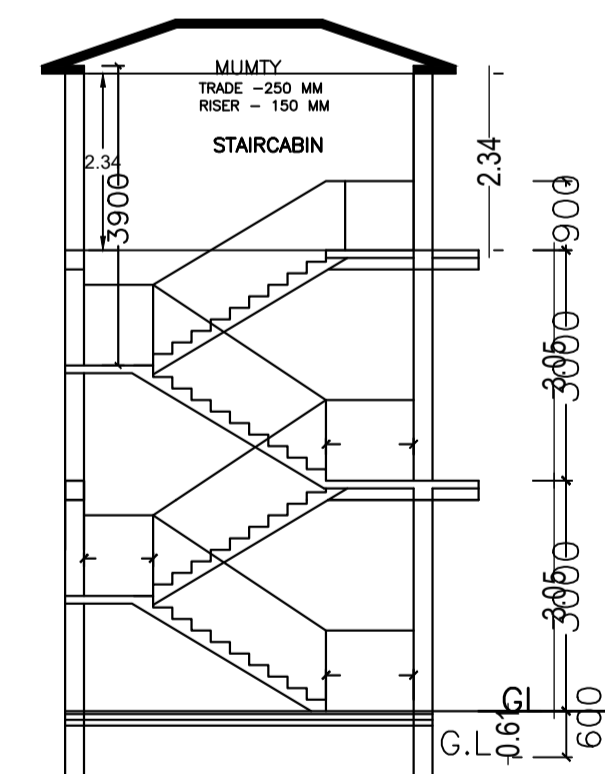

SECTION AT (Y-Y)  
SCALE :- 1"=100

LTP NAME AND SIGNATURE	STRUCTURAL ENG'S NAME AND SIGNATURE	BUILDER NAME AND SIGNATURE	DIGITAL SIGNATURE
SUNIL KUMAR LNP/ENG/0004/2017			

Proposal Basic Information	
Proposal File No.	LNP/BP/0022/W16/2024
Owner Name	VARUN KUMAR GUPTA
Khata No	M/S
Plot No	M/S 1128
Village Name	Lohardaga
Use	Residential
SubUse	Bungalow/ Dwelling / Non Apartment

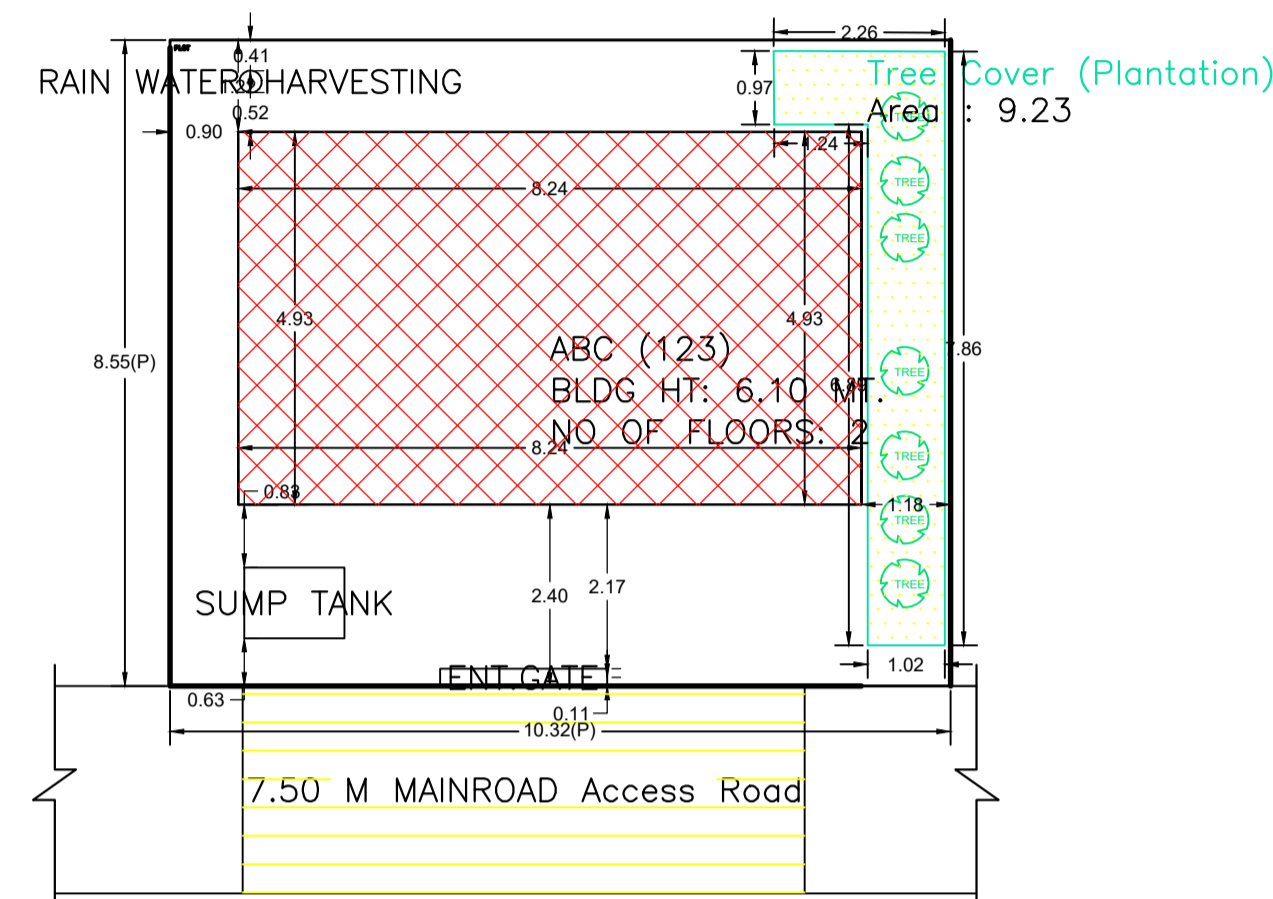
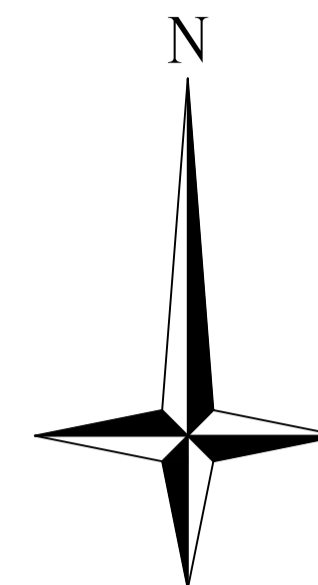

SITE PLAN  
SCALE :- nts

SITE PLAN

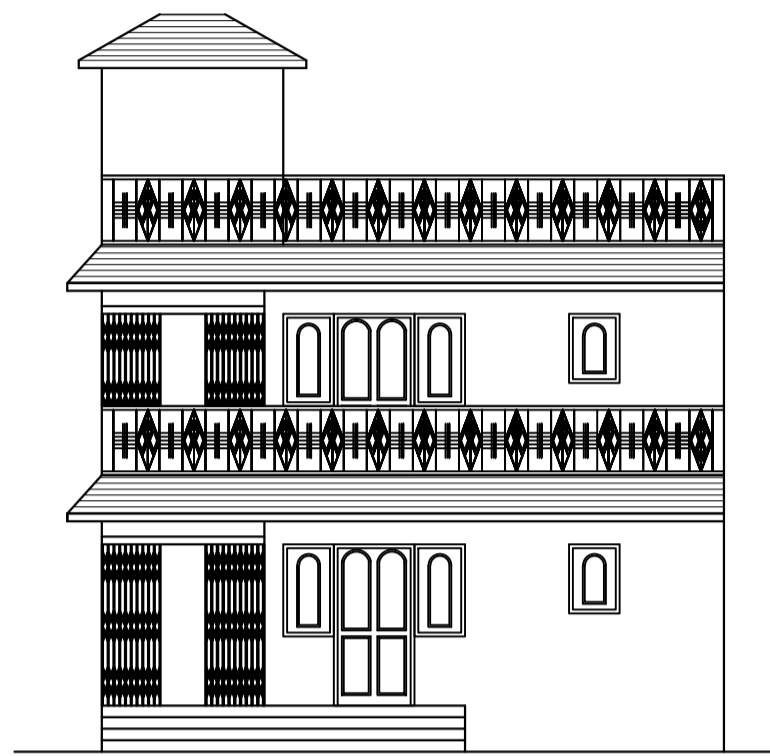

FRONT ELEVATION  
SCALE :- 1"=100

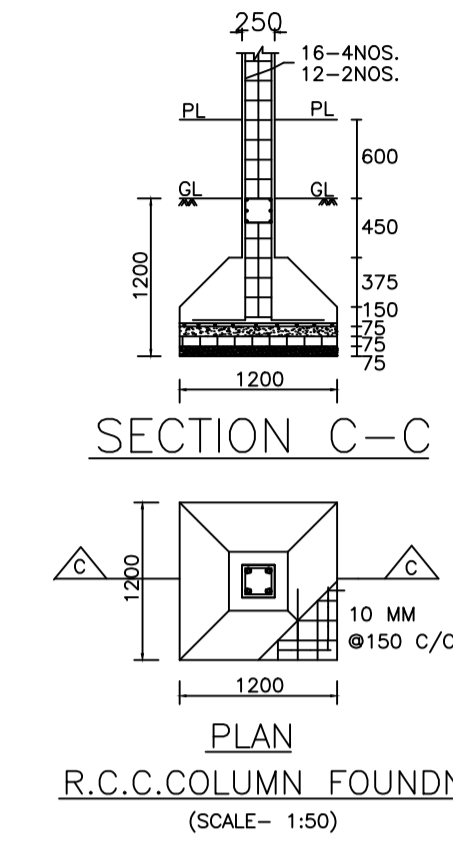

Building USE/SUBUSE Details

Building Name	Building Use	Building SubUse	Building Structure
ABC (123)	Residential	Bungalow/ Dwelling / Non Apartment	Non-Highrise

FAR & Tenement Details (Table 4c-1)

Building	No. of Same Bldg	Total Built Up Area (Sq.mt.)	Deductions (Area in Sq.mt.)		Proposed FAR Area (Sq.mt.)	Total FAR Area (Sq.mt.)	Total Consumed Additional FAR Area (Sq.mt.)	Trmt (No.)
			Balcony	Resi.				
ABC (123)	1	86.28	2.51	83.77	83.77	83.77	83.77	01
Grand Total :	1	86.28	2.51	83.77	83.77	83.77	83.77	01

Buildingwise Floor FAR Details

Floor Name	Building Name ABC (123)		Total	
	Proposed Built Up Area (Sq.mt.)	Proposed FAR Area (Sq.mt.)	Total Proposed Built Up Area (Sq.mt.)	Total FAR Area (Sq.mt.)
Ground Floor	40.63	40.63	40.63	40.63
First Floor	45.65	43.14	45.65	43.14
Terrace Floor	0.00	0.00	0.00	0.00
Total :	86.28	83.77	86.28	83.77

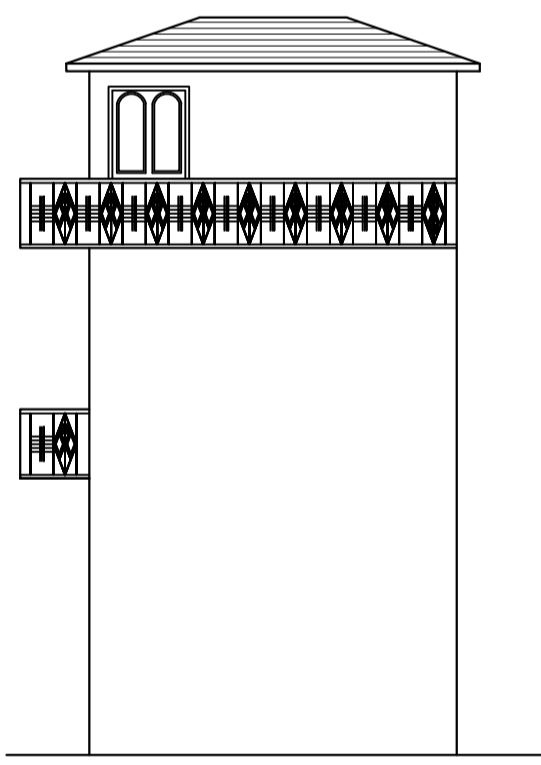

RIGHT SIDE ELEVATION  
SCALE :- 1"=100

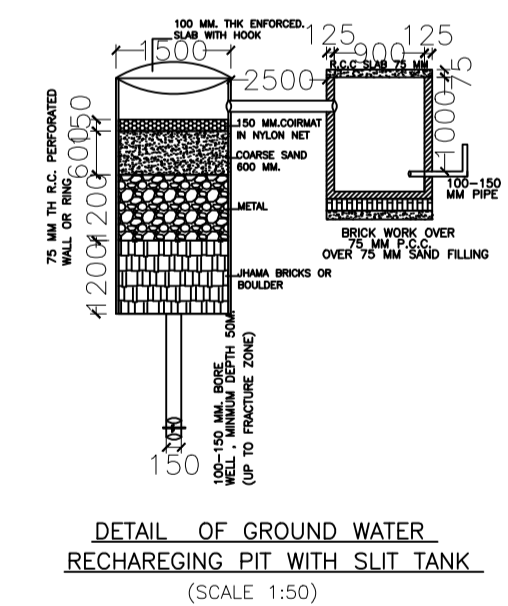

DETAIL OF GROUND WATER RECHARGING PIT WITH SLIT TANK  
(SCALE 1:50)

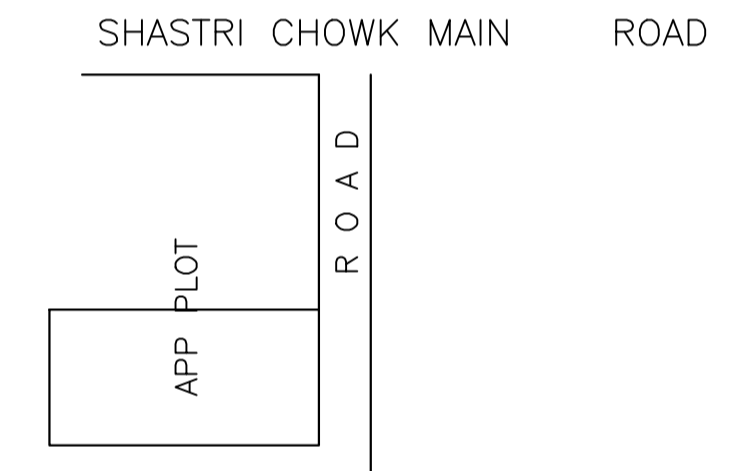

KEY PLAN  
AS PER SITE

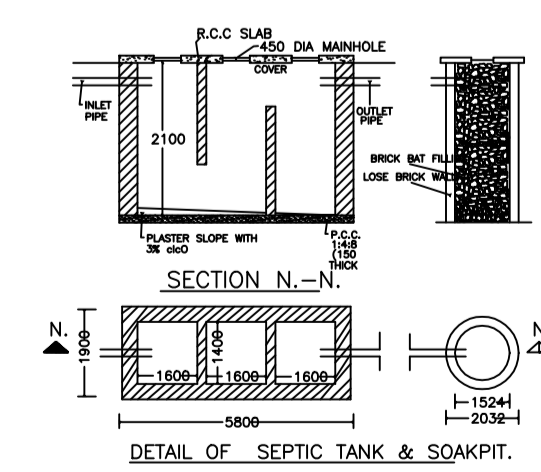

DETAIL OF SEPTIC TANK & SQAMPIT.

COLOR INDEX	
PLOT BOUNDARY	Black
ABUTTING ROAD	Red
PROPOSED CONSTRUCTION	Green
COMMON PLOT	Yellow
ROAD WIDENING AREA	Blue
EXISTING (To be retained)	Light Blue
EXISTING (To be demolished)	Light Yellow

AREA STATEMENT	
LOHARDAGA NAGAR PARISHAD	VERSION NO.: 1.0.69
	VERSION DATE: 16/10/2020
PROJECT DETAIL:	
Region: JHARKHAND URBAN LOCAL BODIES	Plot Use: Residential
District: LOHARDAGA	Plot SubUse: Bungalow/ Dwelling / Non Apartment
Authority: LOHARDAGA NAGAR PARISHAD	PlotNearby/ReligiousStructure: NA
Inward No: LNP/BP/0022/W16/2024	Plot/SubPlot No: M/S 1128
Application Type: General Proposal	North: -
Project Type: Building Permission	South: -
Nature of Development: New	East: -
Location of Development Area: Old Area	West: -
AREA DETAILS:	
AREA OF PLOT (Minimum)	(A) 88.22
NET AREA OF PLOT(Gross Plot Area - Deduction from Gross Plot area)	(A-Deductions) 88.22
Deduction for Balance Plot Area(from Gross Plot Area)	
Common Plot	9.23
Total	9.23
BALANCE AREA OF PLOT(Net Plot Area - Recreational/Amenity space)	(A-Deductions) 78.99
PLOT AREA FOR COVERAGE(Net Plot Area)	(A-Deductions) 88.22
Plot Area for FAR (Net Plot Area + RoadWidening Area)	(A-Deductions) 88.22
COVERAGE CHECK	
Permissible Coverage area ( 70.00 % )	61.75
Proposed Coverage Area ( 46.06 % )	40.63
Total Prop. Coverage Area ( 46.06 % )	40.63
Balance coverage area ( 23.94 % )	21.12
FAR CHECK	
Perm. FAR Area ( 2.000 )	176.44
Total Perm. FAR area	176.44
Residential FAR	83.78
Proposed FAR Area	83.78
Total Proposed FAR Area	83.78
Consumed FAR (Factor)	0.95
Balance FAR Area	92.66
BUILT UP AREA CHECK	
Total Proposed BuiltUp Area	86.28
ARCHITECT (Regd)	SUNIL KUMAR
ENGINEER (Regd)	
SUPERVISOR (Regd)	
OWNER (Regd)	VARUN KUMAR GUPTA
DEVELOPMENT AUTHORITY	LOCAL BODY

LTP NAME AND SIGNATURE	STRUCTURAL ENG'S NAME AND SIGNATURE	BUILDER NAME AND SIGNATURE	DIGITAL SIGNATURE
SUNIL KUMAR LNP/ENG/0004/2017			