

Proposal Basic Information	
Proposal File No.	LNP/EP/0033/W22/2024
Owner Name	ANNU LAKRA
Khata No	117 NEW/113 OLD
Plot No	450 new/357
Village Name	Juriya
Use	Residential
SubUse	Bungalow/ Dwelling / Non Apartment

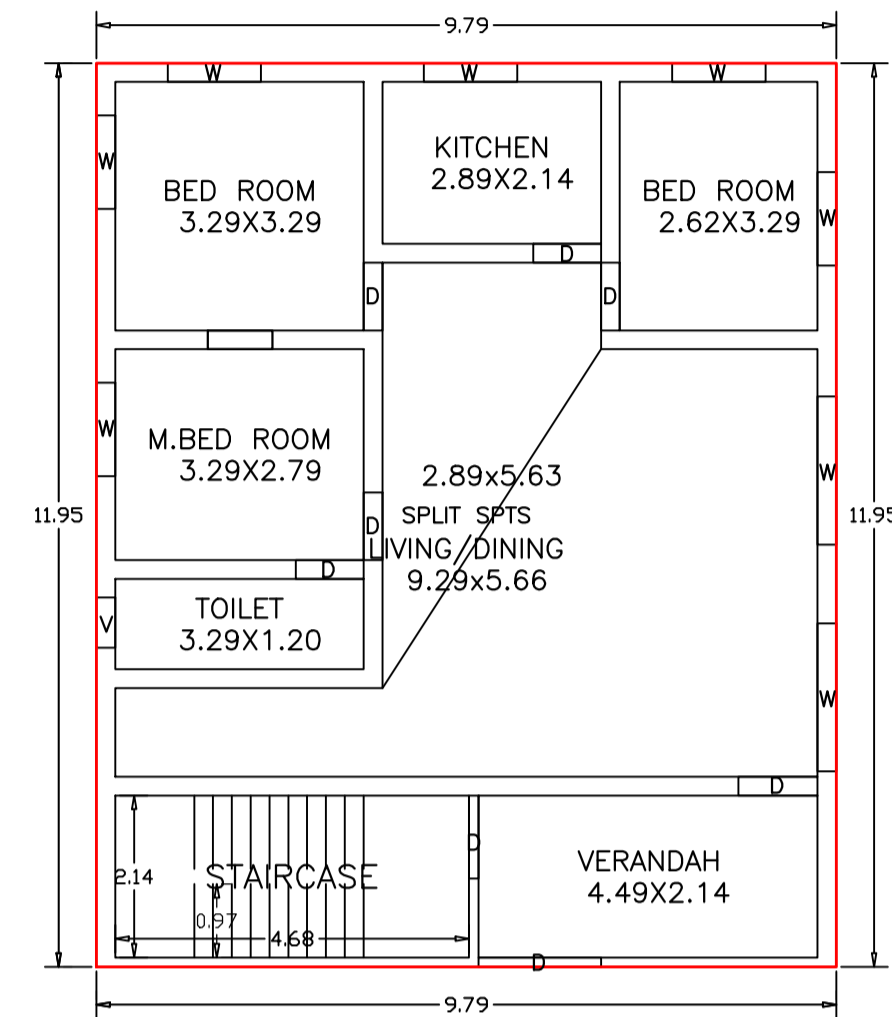

GROUND FLOOR PLAN
(Proposed)
(SCALE 1:100)

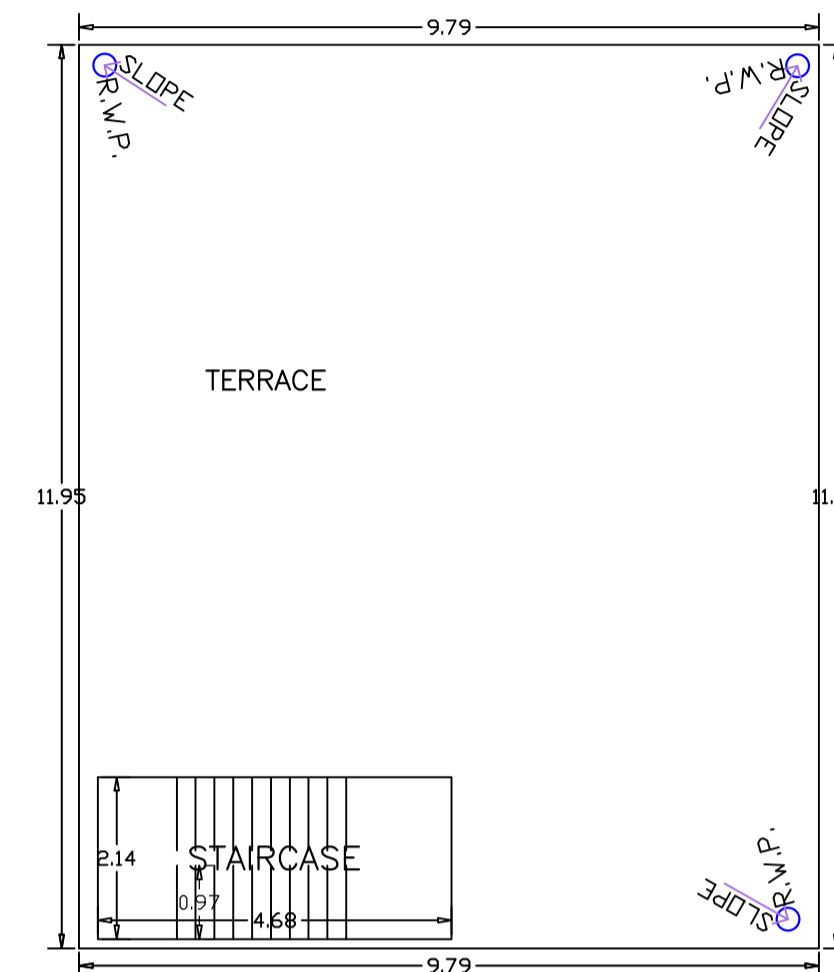

TERRACE FLOOR PLAN
(SCALE 1:100)

UnitBUA Table for Building :ABC (123)

FLOOR	Name	UnitBUA Type	UnitBUA Area	Carpet Area	No. of Rooms	No. of Tenement
GROUND FLOOR PLAN	SPLIT SPTS	FLAT	116.99	116.77	7	1
Total:	-	-	116.99	116.77	7	1

SCHEDULE OF DOOR:

BUILDING NAME	NAME	LENGTH	HEIGHT	NOS
ABC (123)	D	0.90	2.10	05
ABC (123)	D	1.05	2.10	01
ABC (123)	D	1.10	2.10	01
ABC (123)	D	1.62	2.10	01

SCHEDULE OF WINDOW/VENTILATION:

BUILDING NAME	NAME	LENGTH	HEIGHT	NOS
ABC (123)	V	0.67	1.20	01
ABC (123)	W	1.23	1.20	06
ABC (123)	W	1.96	1.20	02

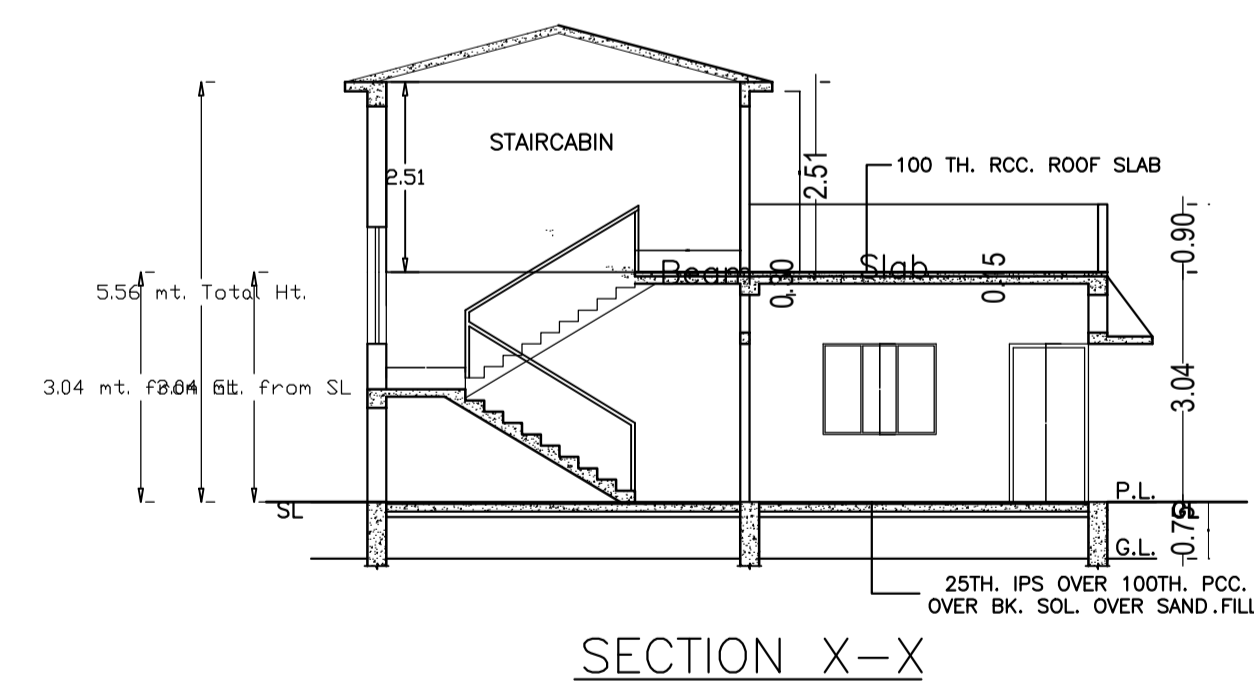

SECTION X-X

Building :ABC (123)

Floor Name	Total Built Up Area (Sq.mt.)	Proposed FAR Area (Sq.mt.) Resi.	Total FAR Area (Sq.mt.)	Total Consumed Additional FAR Area (Sq.mt.)	Tnmt (No.)
Ground Floor	116.99	116.99	116.99	116.99	01
Terrace Floor	0.00	0.00	0.00	0.00	00
Total	116.99	116.99	116.99	116.99	01
Total Number of Same Buildings	1				
Total :	116.99	116.99	116.99	116.99	01

LTP NAME AND SIGNATURE	STRUCTURAL ENG'S NAME AND SIGNATURE	BUILDER NAME AND SIGNATURE	DIGITAL SIGNATURE
SUNIL KUMAR LNP/ENG/0004/2017			

Proposal Basic Information	
Proposal File No.	LNP/BP/0033/W22/2024
Owner Name	ANNU LAKRA
Khata No	117 NEW/113 OLD
Plot No	450 new/357
Village Name	Juriya
Use	Residential
SubUse	Bungalow/ Dwelling / Non Apartment

Building USE/SUBUSE Details			
Building Name	Building Use	Building SubUse	Building Structure
ABC (123)	Residential	Bungalow/ Dwelling / Non Apartment	Non-Highrise

FAR & Tenement Details (Table 4c-1)						
Building	No. of Same Bldg	Total Built Up Area (Sq.mt.)	Proposed FAR Area (Sq.mt.) Resi.	Total FAR Area (Sq.mt.)	Total Consumed Additional FAR Area (Sq.mt.)	Tnmt (No.)
ABC (123)	1	116.99	116.99	116.99	116.99	01
Grand Total :	1	116.99	116.99	116.99	116.99	01

Buildingwise Floor FAR Details				
Floor Name	Building Name		Total	
	Proposed Built Up Area (Sq.mt.)	Proposed FAR Area (Sq.mt.)	Total Proposed Built Up Area (Sq.mt.)	Total FAR Area (Sq.mt.)
Ground Floor	116.99	116.99	116.99	116.99
Terrace Floor	0.00	0.00	0.00	0.00
Total :	116.99	116.99	116.99	116.99

AREA STATEMENT		VERSION NO. : 1.0.70
LOHARDAGA NAGAR PARISHAD		VERSION DATE: 16/10/2020
PROJECT DETAIL:		
Region: JHARKHAND URBAN LOCAL BODIES	Plot Use: Residential	
District: LOHARDAGA	Plot SubUse: Bungalow/ Dwelling / Non Apartment	
Authority: LOHARDAGA NAGAR PARISHAD	PlotNearby/ReligiousStructure: NA	
Inward_No: LNP/BP/0033/W22/2024	Plot/SubPlot No: 450 new/357	
Application Type: General Proposal	North: -	
Project Type: Building Permission	South: -	
Nature of Development: New	East: -	
Location of Development Area: Old Area	West: -	
AREA DETAILS:		
AREA OF PLOT (Minimum)	(A)	SQ.MT. 282.40
Deduction for NetPlot Area	Surrender Free of Cost	22.10
Total		22.10
NET AREA OF PLOT(Gross Plot Area - Deduction from Gross Plot area)	(A-Deductions)	260.30
Deduction for Balance Plot Area(from Gross Plot Area)		
Surrender Free of Cost		22.10
Common Plot		46.67
Total		68.77
BALANCE AREA OF PLOT(Net Plot Area - Recreational/Amenity space)	(A-Deductions)	213.63
PLOT AREA FOR COVERAGE(Net Plot Area)	(A-Deductions)	260.30
Plot Area for FAR (Net Plot Area + Road/Widening Area)	(A-Deductions)	282.40
COVERAGE CHECK		
Permissible Coverage area (60.00 %)		156.18
Proposed Coverage Area (44.94 %)		116.99
Total Prop. Coverage Area (44.94 %)		116.99
Balance coverage area (15.06 %)		39.19
FAR CHECK		
Perm. FAR Area (1.200)		338.88
Total Perm. FAR area		338.88
Residential FAR		116.99
Proposed FAR Area		116.99
Total Proposed FAR Area		116.99
Consumed FAR (Factor)		0.41
Balance FAR Area		221.89
BUILT UP AREA CHECK		
Total Proposed BuiltUp Area		116.99
ARCHITECT (Regd)	SUNIL KUMAR	
ENGINEER (Regd)		
SUPERVISOR (Regd)		
OWNER (Regd)	ANNU LAKRA	
DEVELOPMENT AUTHORITY		LOCAL BODY

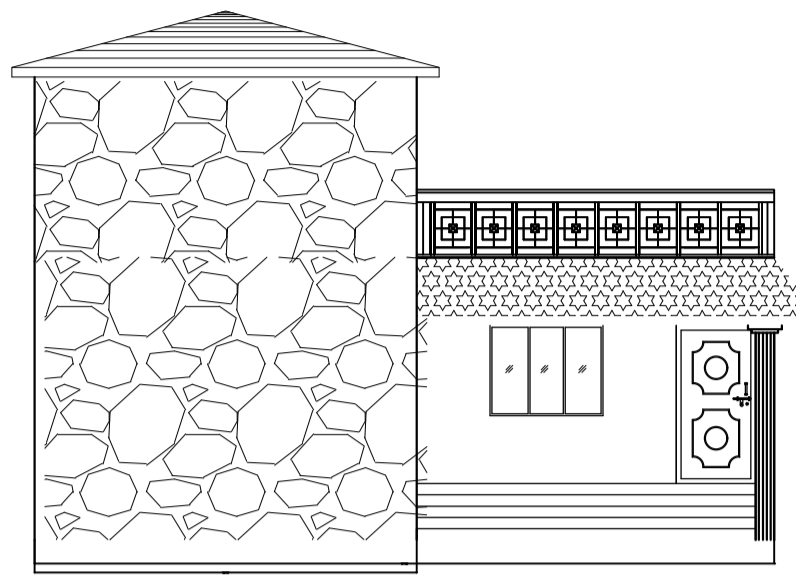

FRONT ELEVATION

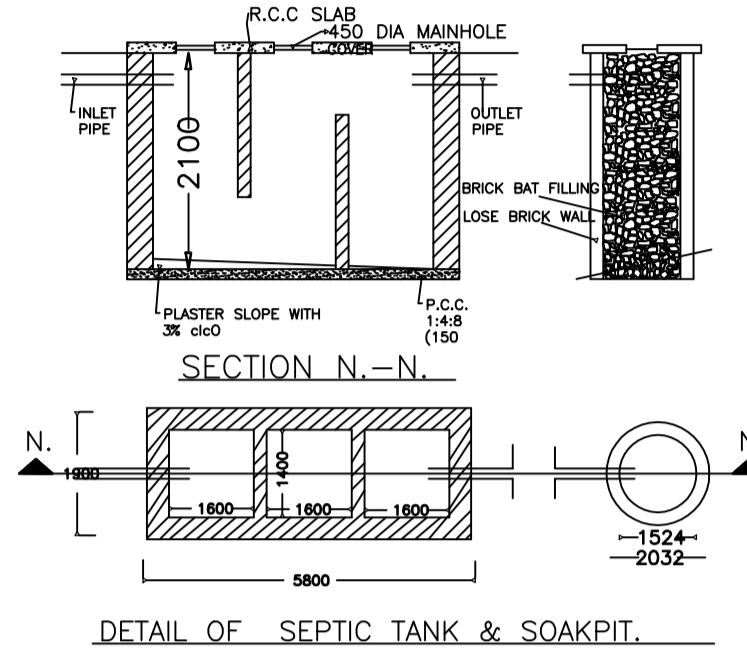

DETAIL OF SEPTIC TANK & SOAKPIT.



SITE PLAN SCALE-1:100

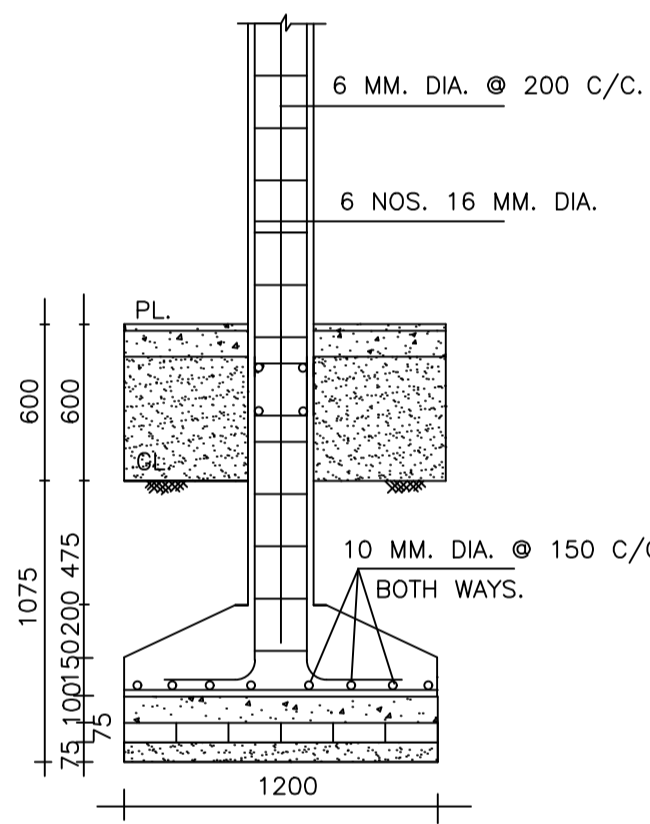

R.C.C. COLUMN (250 X 250) SCALE -- 1 : 25.

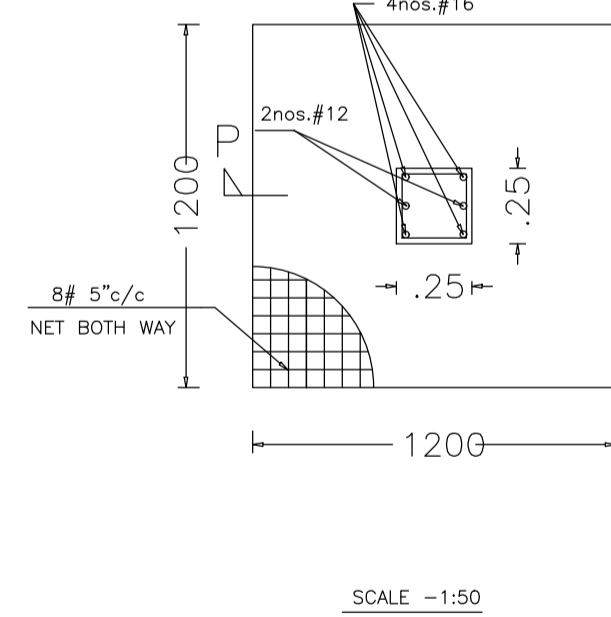

SCALE -1:50

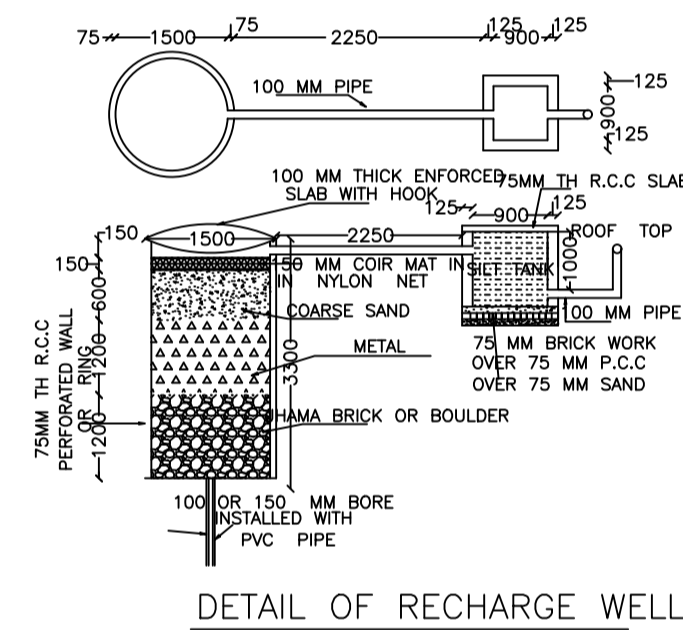

DETAIL OF RECHARGE WELL

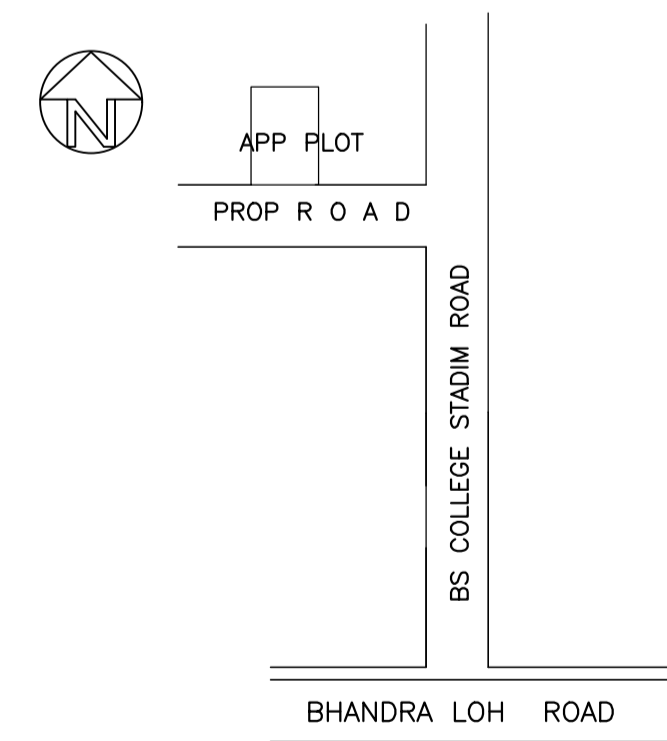

KEY & LOCATION PLAN

COLOR INDEX	
PLOT BOUNDARY	[Red Line]
ABUTTING ROAD	[Green Line]
PROPOSED CONSTRUCTION	[Blue Line]
COMMON PLOT	[Yellow Line]
ROAD WIDENING AREA	[Orange Line]
EXISTING (To be retained)	[Light Blue Line]
EXISTING (To be demolished)	[Light Yellow Line]

LTP NAME AND SIGNATURE	STRUCTURAL ENG'S NAME AND SIGNATURE	BUILDER NAME AND SIGNATURE	DIGITAL SIGNATURE
SUNIL KUMAR LNP/ENG/0004/2017			