

Proposal Basic Information	
Proposal File No.	MNNP/BP/0006/W04/2019
Owner Name	PRIYANKA PANDEY
Khata No	275
Plot No	79
Village Name	Baralota Rodma
Use	Residential
SubUse	Bungalow/ Dwelling / Non Apartment

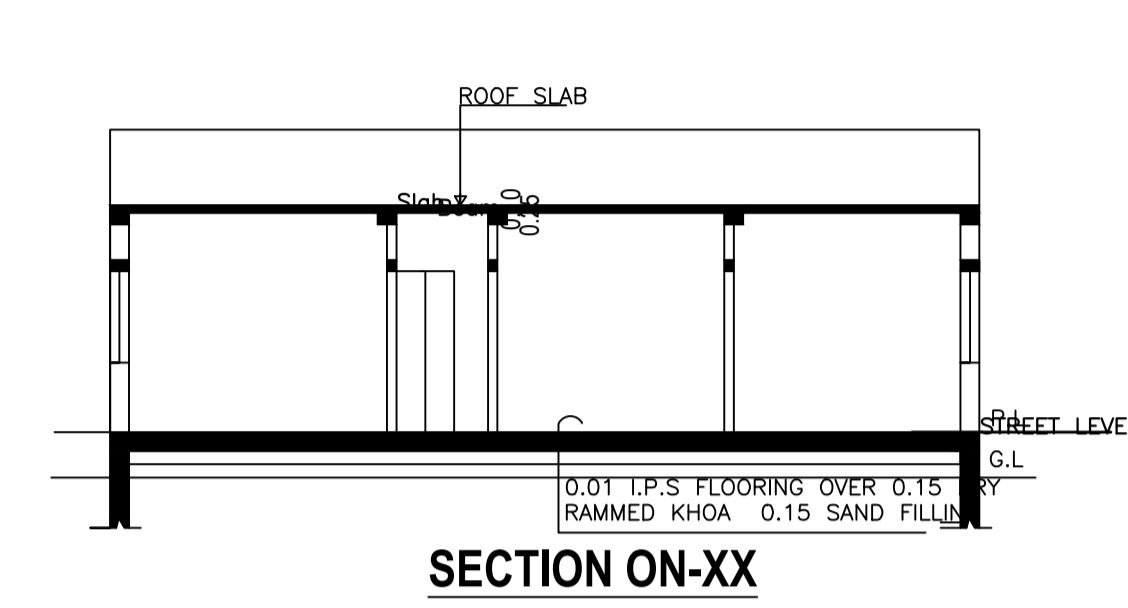
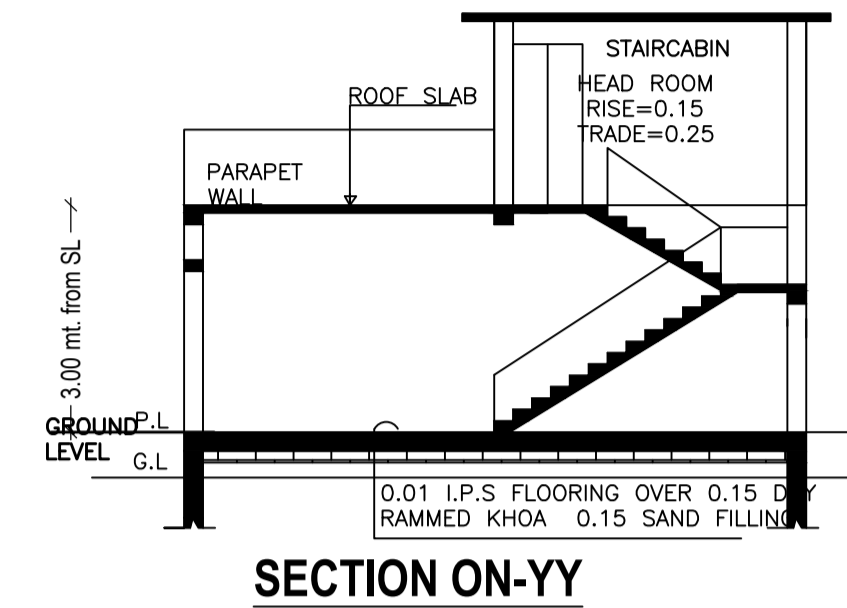
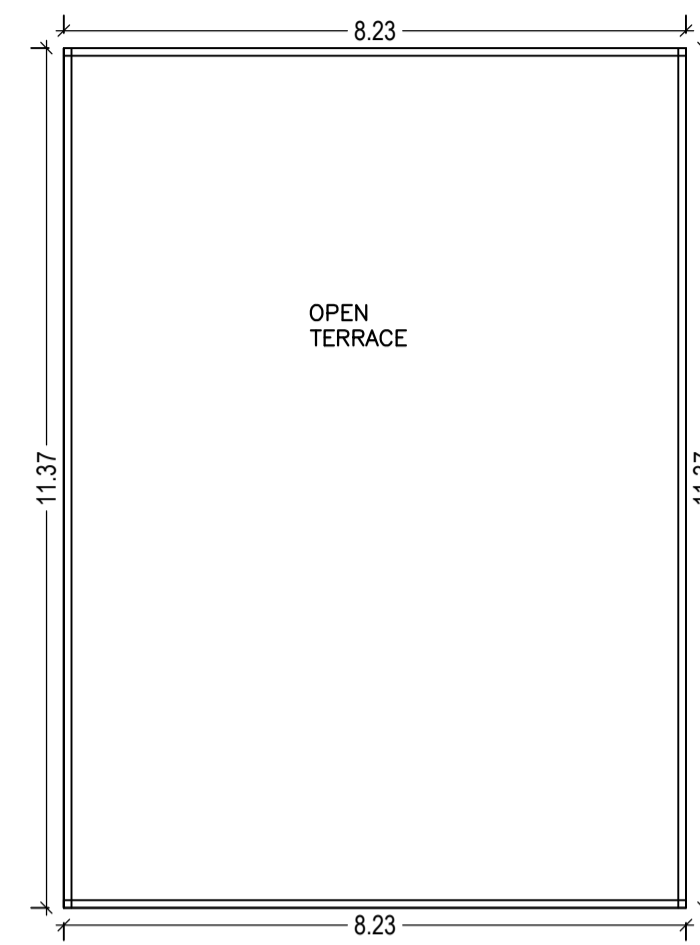
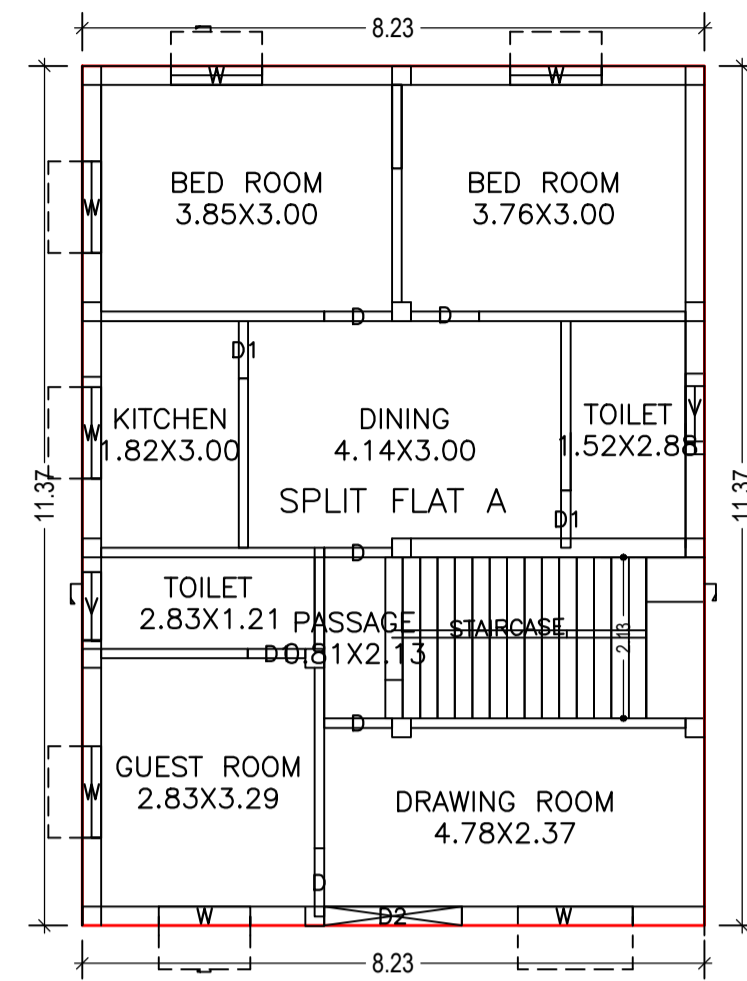
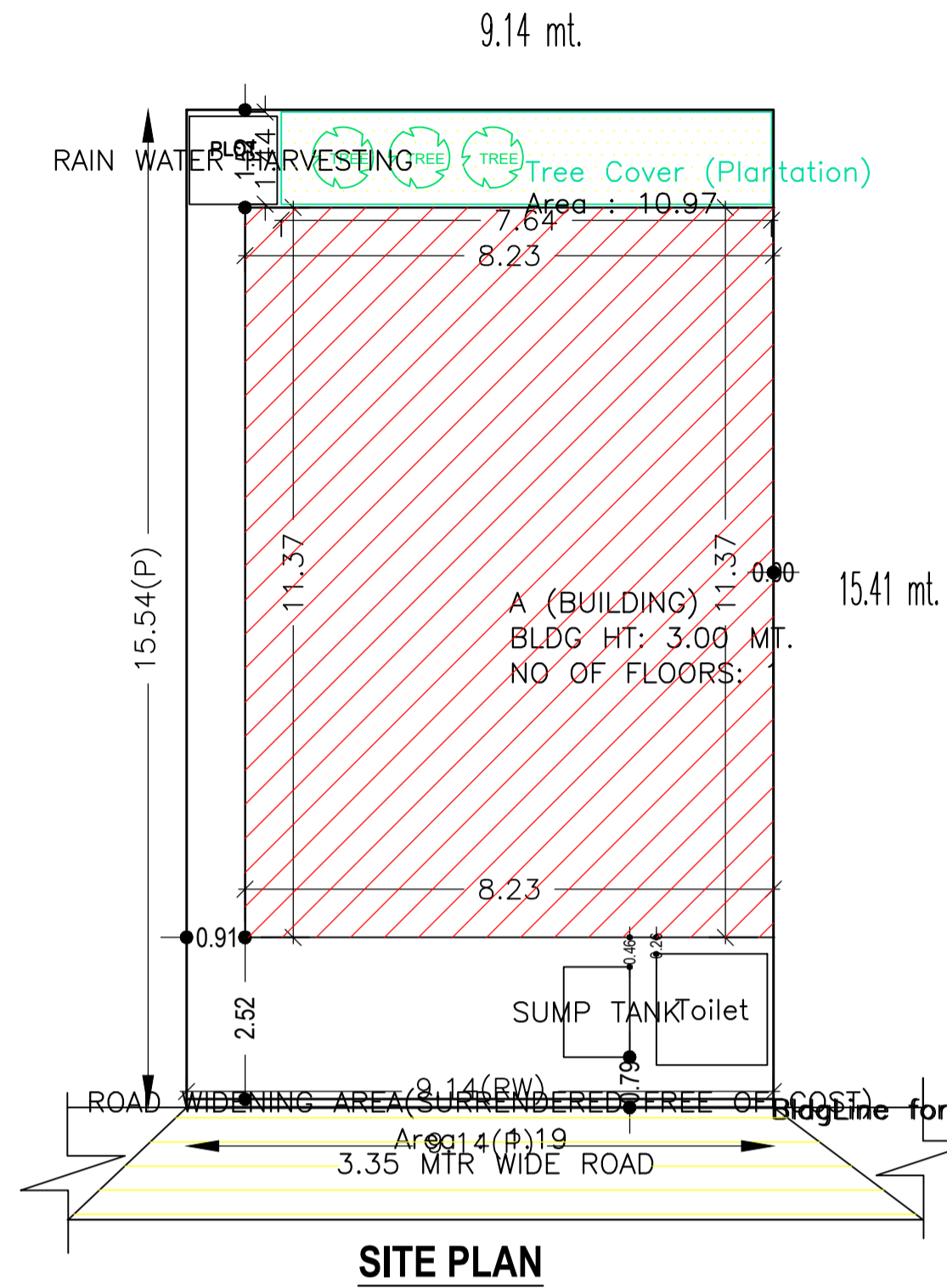

AREA STATEMENT		VERSION NO.: 1.0.32
MEDINAGAR NAGAR PARISHAD		VERSION DATE: 10/05/2018
PROJECT DETAIL:		
Region: JHARKHAND URBAN LOCAL BODIES	Plot Use: Residential	
District: PALAMU	Plot SubUse: Bungalow/ Dwelling / Non Apartment	
Authority: MEDINAGAR NAGAR PARISHAD	Plot/Nearby/Religious/Structure: NA	
Inward No: MNNP/BP/0006/W04/2019	Plot/SubPlot No: 79	
Application Type: General Proposal	North: -	
Project Type: Building Permission	South: -	
Nature of Development: New	East: -	
Location of Development Area: Old Area	West: -	
AREA DETAILS:		
AREA OF PLOT (Minimum)	(A)	SQ.MT. 142.04
Deduction for NetPlot Area		
Surrender Free of Cost		1.19
Total		1.19
NET AREA OF PLOT(Gross Plot Area - Deduction from Gross Plot area)	(A-Deductions)	140.85
Deduction for Balance Plot Area(from Gross Plot Area)		
Surrender Free of Cost		1.19
Common Plot		10.97
Total		12.16
BALANCE AREA OF PLOT(Net Plot Area - Recreational/Amenity space)	(A-Deductions)	129.88
PLOT AREA FOR COVERAGE(Net Plot Area)	(A-Deductions)	140.85
Plot Area for FAR (Net Plot Area + RoadWidening Area)	(A-Deductions)	142.04
COVERAGE CHECK		
Permissible Coverage area (70.00 %)		98.60
Proposed Coverage Area (66.44 %)		93.58
Total Prop. Coverage Area (66.44 %)		93.58
Balance coverage area (3.56 %)		5.02
FAR CHECK		
Perm. FAR Area (1.20)		170.45
Total Perm. FAR area		170.45
Residential FAR		93.58
Proposed FAR Area		93.58
Total Proposed FAR Area		93.58
Consumed FAR (Factor)		0.66
Balance FAR Area		76.87
BUILT UP AREA CHECK		
Total Proposed BuiltUp Area		93.58
ARCHITECT (Regd)		RANJIT KUMAR
ENGINEER (Regd)		
SUPERVISOR (Regd)		PRIYANKA PANDEY
OWNER (Regd)		
DEVELOPMENT AUTHORITY		LOCAL BODY

COLOR INDEX	
PLOT BOUNDARY	Black
ABUTTING ROAD	Green
PROPOSED CONSTRUCTION	Red
COMMON PLOT	Yellow
ROAD WIDENING AREA	Orange
EXISTING (To be retained)	Blue
EXISTING (To be demolished)	Light Blue

Buildingwise Floor FAR Details				
Floor Name	Building Name A (BUILDING)		Total	
	Proposed Built Up Area (Sq.mt.)	Proposed FAR Area (Sq.mt.)	Total Proposed Built Up Area (Sq.mt.)	Total FAR Area (Sq.mt.)
Ground Floor	93.58	93.58	93.58	93.58
Terrace Floor	0.00	0.00	0.00	0.00
Total :	93.58	93.58	93.58	93.58

Building USE/SUBUSE Details			
Building Name	Building Use	Building SubUse	Building Structure
A (BUILDING)	Residential	Bungalow/ Dwelling / Non Apartment	Non-Highrise

FAR & Tenement Details (Table 4c-1)						
Building	No. of Same Bldg	Total Built Up Area (Sq.mt.)	Proposed FAR Area (Sq.mt.)	Total FAR Area (Sq.mt.)	Total Consumed Additional FAR Area (Sq.mt.)	Tnmt (No.)
A (BUILDING)	1	93.58	93.58	93.58	93.58	01
Grand Total :		93.58	93.58	93.58	93.58	01

UnitBUA Table for Building :A (BUILDING)						
FLOOR	Name	UnitBUA Type	UnitBUA Area	Carpet Area	No. of Rooms	No. of Tenement
GROUND FLOOR PLAN	SPLIT FLAT A	FLAT	74.58	74.44	9	1
Total :			74.58	74.44	9	1

Building :A (BUILDING)					
Floor Name	Total Built Up Area (Sq.mt.)	Proposed FAR Area (Sq.mt.)	Total FAR Area (Sq.mt.)	Total Consumed Additional FAR Area (Sq.mt.)	Tnmt (No.)
Ground Floor	93.58	93.58	93.58	93.58	01
Terrace Floor	0.00	0.00	0.00	0.00	00
Total :	93.58	93.58	93.58	93.58	01
Total Number of Same Buildings :	1				
Total :	93.58	93.58	93.58	93.58	01

SCHEDULE OF DOOR:				
BUILDING NAME	NAME	LENGTH	HEIGHT	NOS
A (BUILDING)	D1	0.76	2.10	03
A (BUILDING)	D	0.90	2.10	05
A (BUILDING)	D2	1.82	2.10	01

SCHEDULE OF WINDOW/VENTILATION:				
BUILDING NAME	NAME	LENGTH	HEIGHT	NOS
A (BUILDING)	V	0.90	0.60	02
A (BUILDING)	W	1.21	1.20	06
A (BUILDING)	W	1.52	1.20	01

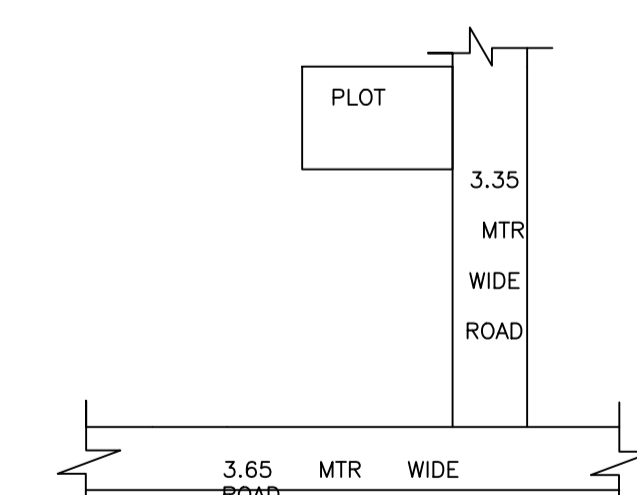
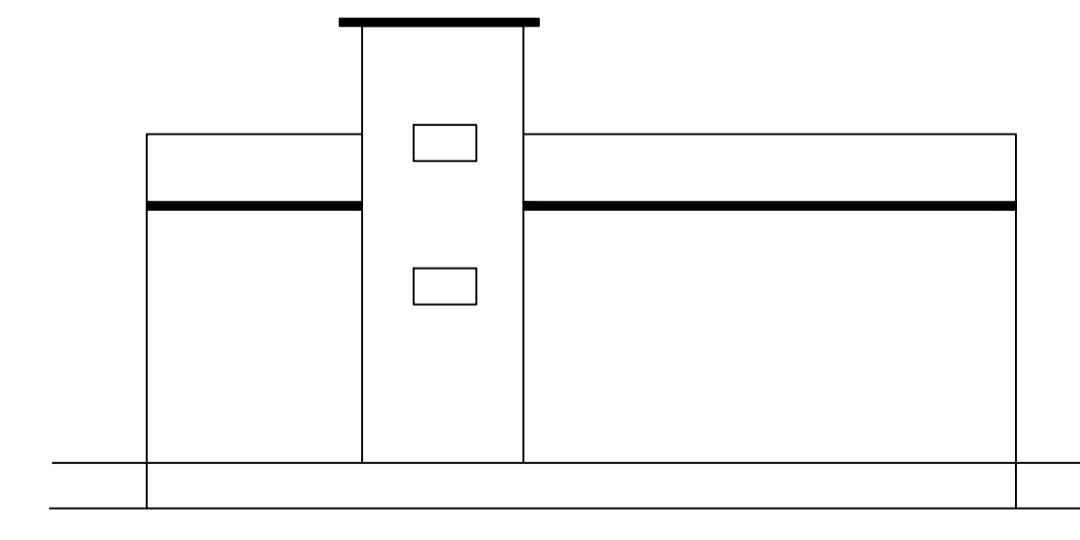
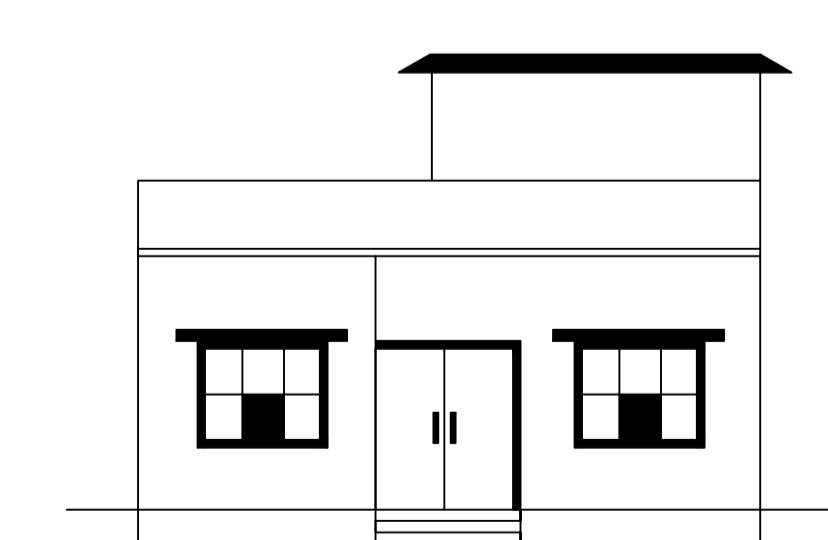
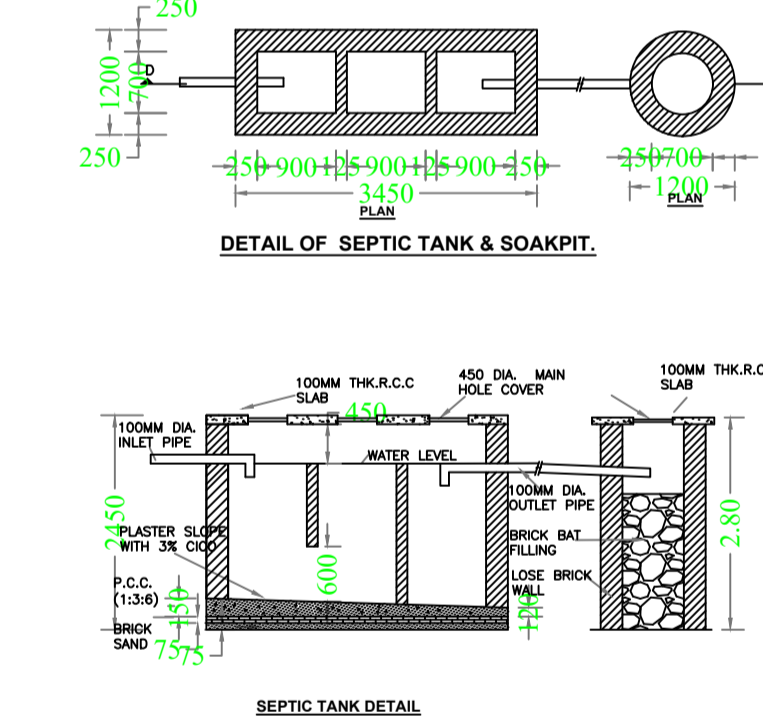
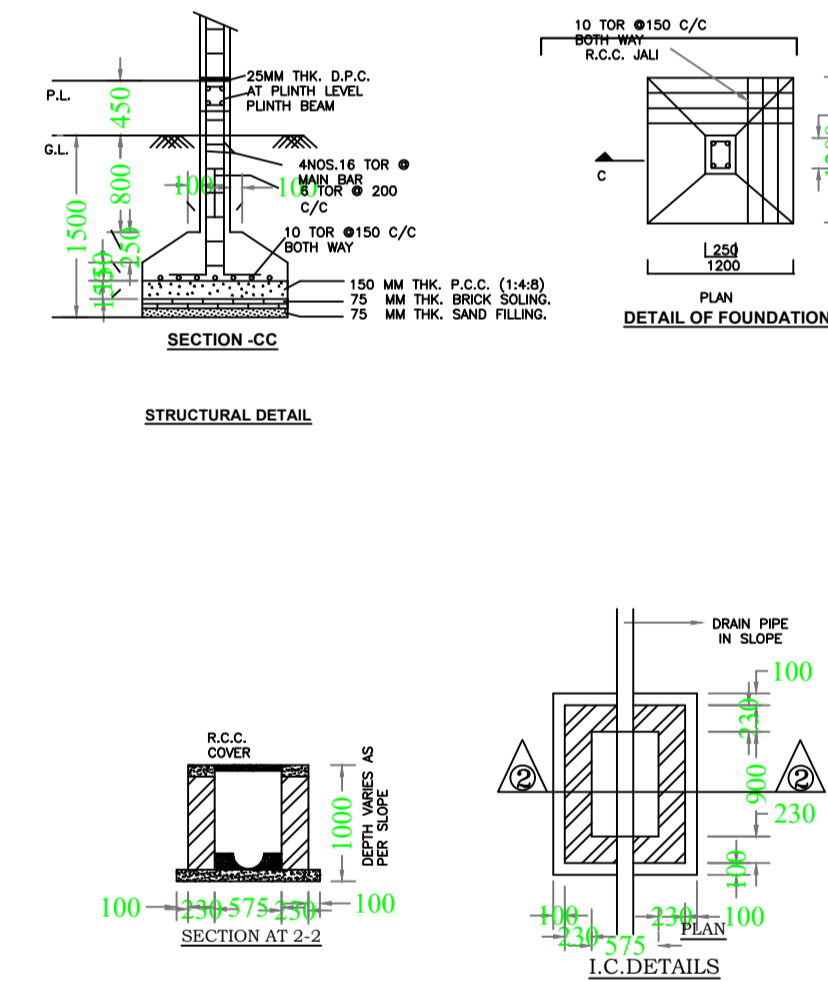
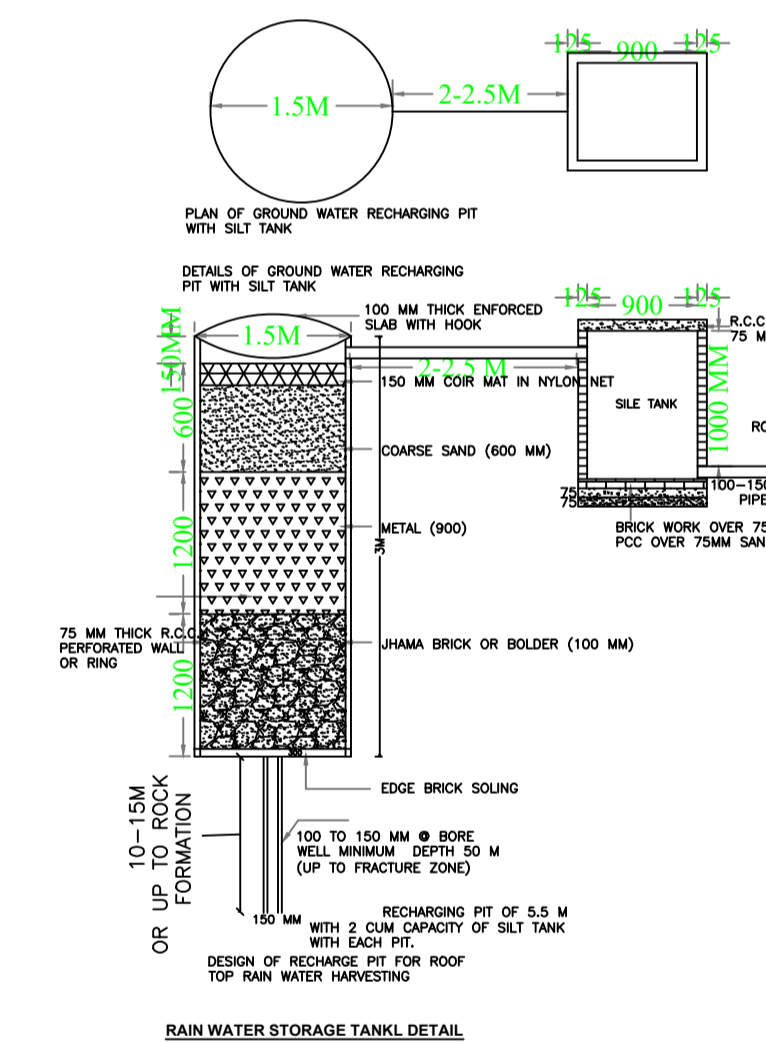

LTP NAME AND SIGNATURE	STRUCTURAL ENG'S NAME AND SIGNATURE	BUILDER NAME AND SIGNATURE	DIGITAL SIGNATURE
RANJIT KUMAR MNNP/ENG/0001/2016			