

Proposal Basic Information	
Proposal File No.	MNNP/BI/0029/W17/2019
Owner Name	KIRAN DUBEY
Khata No	491
Plot No	1598
Village Name	Baralota Rodma
Use	Residential
SubUse	Bungalow/ Dwelling / Non Apartment

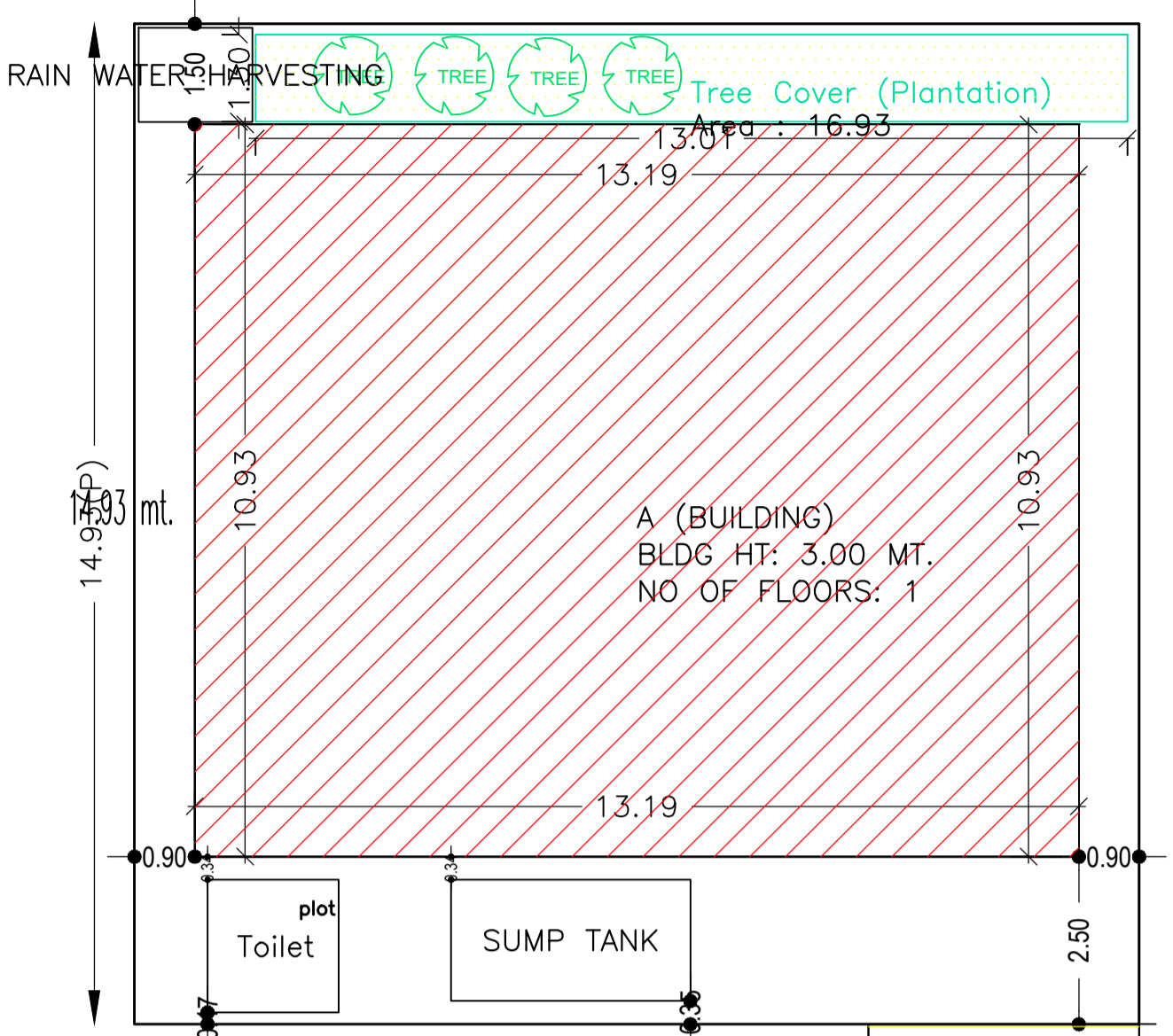

SITE PLAN

AREA STATEMENT		VERSION NO: 1.0.36
MEDININAGAR NAGAR PARISHAD		VERSION DATE: 29/04/2019
PROJECT DETAIL:		
Region: JHARKHAND URBAN	Plot Use: Residential	
LOCAL BODIES	Plot SubUse: Bungalow/ Dwelling / Non Apartment	
District: PALAMU	PlotNearbyReligiousStructure: NA	
Authority: MEDININAGAR NAGAR PARISHAD		
Inward No: MNNP/BI/0029/W17/2019	Plot/SubPlot No: 1598	
Application Type: General Proposal	North: -	
Project Type: Building Permission	South: -	
Nature of Development: New	East: -	
Location of Development Area: Old Area	West: -	
AREA DETAILS: SQ.MT.		
AREA OF PLOT (Minimum)	(A)	223.80
NET AREA OF PLOT(Gross Plot Area - Deduction from Gross Plot area)	(A-Deductions)	223.80
Deduction for Balance Plot Area(from Gross Plot Area)		
Common Plot		16.93
Total		16.93
BALANCE AREA OF PLOT(Nat Plot Area - Recreational/Amenity space)	(A-Deductions)	206.87
PLOT AREA FOR COVERAGE(Nat Plot Area)	(A-Deductions)	223.80
Plot Area for FAR (Net Plot Area + Road/Widening Area)	(A-Deductions)	223.80
COVERAGE CHECK		
Permissible Coverage area ( 70.00 % )		156.66
Proposed Coverage Area ( 64.42 % )		144.17
Total Prop. Coverage Area ( 64.42 % )		144.17
Balance coverage area ( 5.58 % )		12.49
FAR CHECK		
Perm. FAR Area ( 1.20 )		268.56
Total Perm. FAR area		268.56
Residential FAR		144.17
Proposed FAR Area		144.17
Total Proposed FAR Area		144.17
Consumed FAR (Factor)		0.64
Balance FAR Area		124.39
BUILT UP AREA CHECK		
Total Proposed BuiltUp Area		144.17
ARCHITECT (Regd)	RANJIT KUMAR	
ENGINEER (Regd)		
SUPERVISOR (Regd)		
OWNER (Regd)	KIRAN DUBEY	
DEVELOPMENT AUTHORITY LOCAL BODY		

COLOR INDEX	
PLOT BOUNDARY	Black
ABUTTING ROAD	Green
PROPOSED CONSTRUCTION	Red
COMMON PLOT	Yellow
ROAD WIDENING AREA	Blue
EXISTING (To be retained)	Orange
EXISTING (To be demolished)	Light Blue

Buildingwise Floor FAR Details

Floor Name	Building Name		Total	
	Proposed Built Up Area (Sq.mt.)	Proposed FAR Area (Sq.mt.)	Total Proposed Built Up Area (Sq.mt.)	Total FAR Area (Sq.mt.)
Ground Floor	144.17	144.17	144.17	144.17
Terrace Floor	0.00	0.00	0.00	0.00
<b>Total</b>	<b>144.17</b>	<b>144.17</b>	<b>144.17</b>	<b>144.17</b>

Building Name	Building Use	Building SubUse	Building Structure
A (BUILDING)	Residential	Bungalow/ Dwelling / Non Apartment	Non-Highrise

FAR & Tenement Details (Table 4c-1)

Building	No. of Same Bldg	Total Built Up Area (Sq.mt.)	Proposed FAR Area (Sq.mt.)	Total FAR Area (Sq.mt.)	Total Consumed Additional FAR Area (Sq.mt.)	Tnmt (No.)
A (BUILDING)	1	144.17	144.17	144.17	144.17	01
<b>Grand Total</b>	<b>1</b>	<b>144.17</b>	<b>144.17</b>	<b>144.17</b>	<b>144.17</b>	<b>01</b>

Building :A (BUILDING)

Floor Name	Total Built Up Area (Sq.mt.)	Proposed FAR Area (Sq.mt.)	Total FAR Area (Sq.mt.)	Total Consumed Additional FAR Area (Sq.mt.)	Tnmt (No.)
Ground Floor	144.17	144.17	144.17	144.17	01
Terrace Floor	0.00	0.00	0.00	0.00	00
<b>Total</b>	<b>144.17</b>	<b>144.17</b>	<b>144.17</b>	<b>144.17</b>	<b>01</b>

SCHEDULE OF DOOR:

BUILDING NAME	NAME	LENGTH	HEIGHT	NOS
A (BUILDING)	D1	0.76	2.10	05
A (BUILDING)	D	0.90	2.10	07
A (BUILDING)	D2	1.21	2.10	01

SCHEDULE OF WINDOW/VENTILATION:

BUILDING NAME	NAME	LENGTH	HEIGHT	NOS
A (BUILDING)	V	0.90	0.60	02
A (BUILDING)	W	1.20	1.20	05
A (BUILDING)	W	1.50	1.20	05

UnitBUA Table for Building :A (BUILDING)

FLOOR	Name	UnitBUA Type	UnitBUA Area	Carpet Area	No. of Rooms	No. of Tenement
GROUND FLOOR PLAN	A	FLAT	132.53	132.15	12	1
<b>Total:</b>	-	-	<b>132.53</b>	<b>132.15</b>	<b>12</b>	<b>1</b>

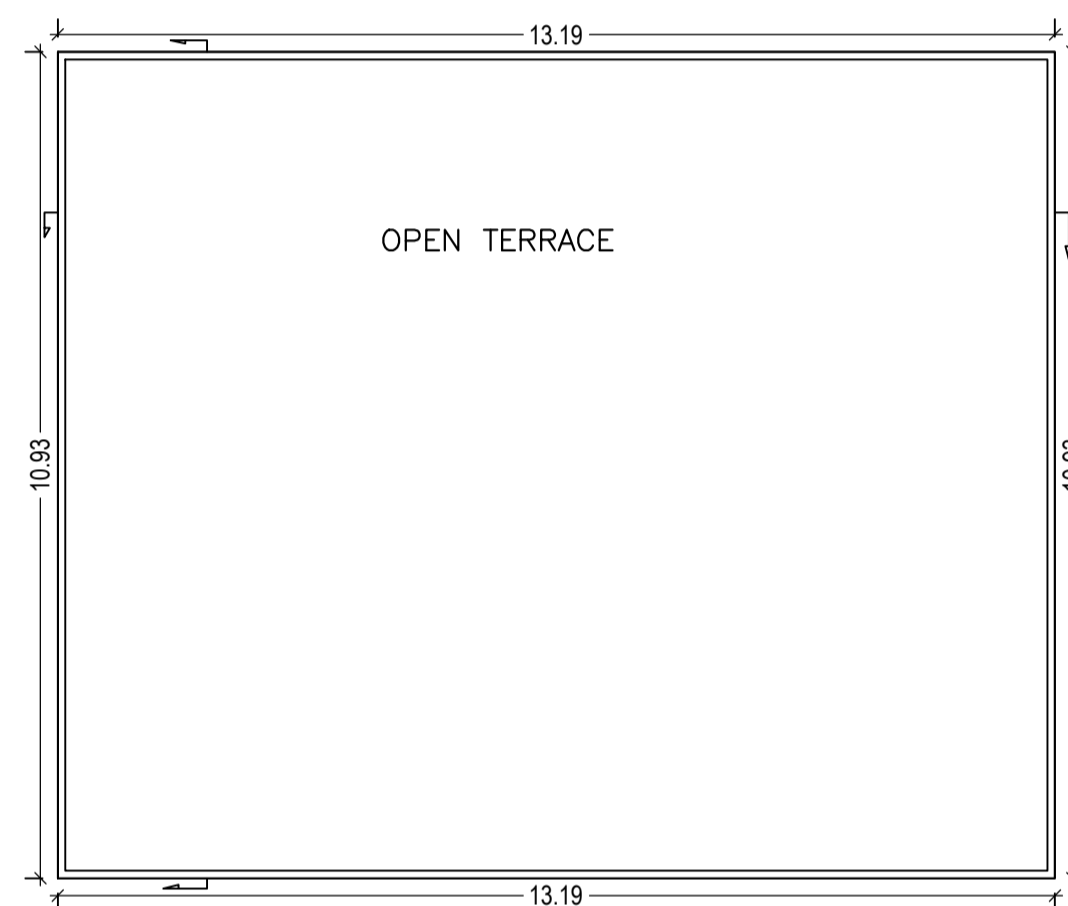

TERRACE FLOOR PLAN (SCALE 1:100)

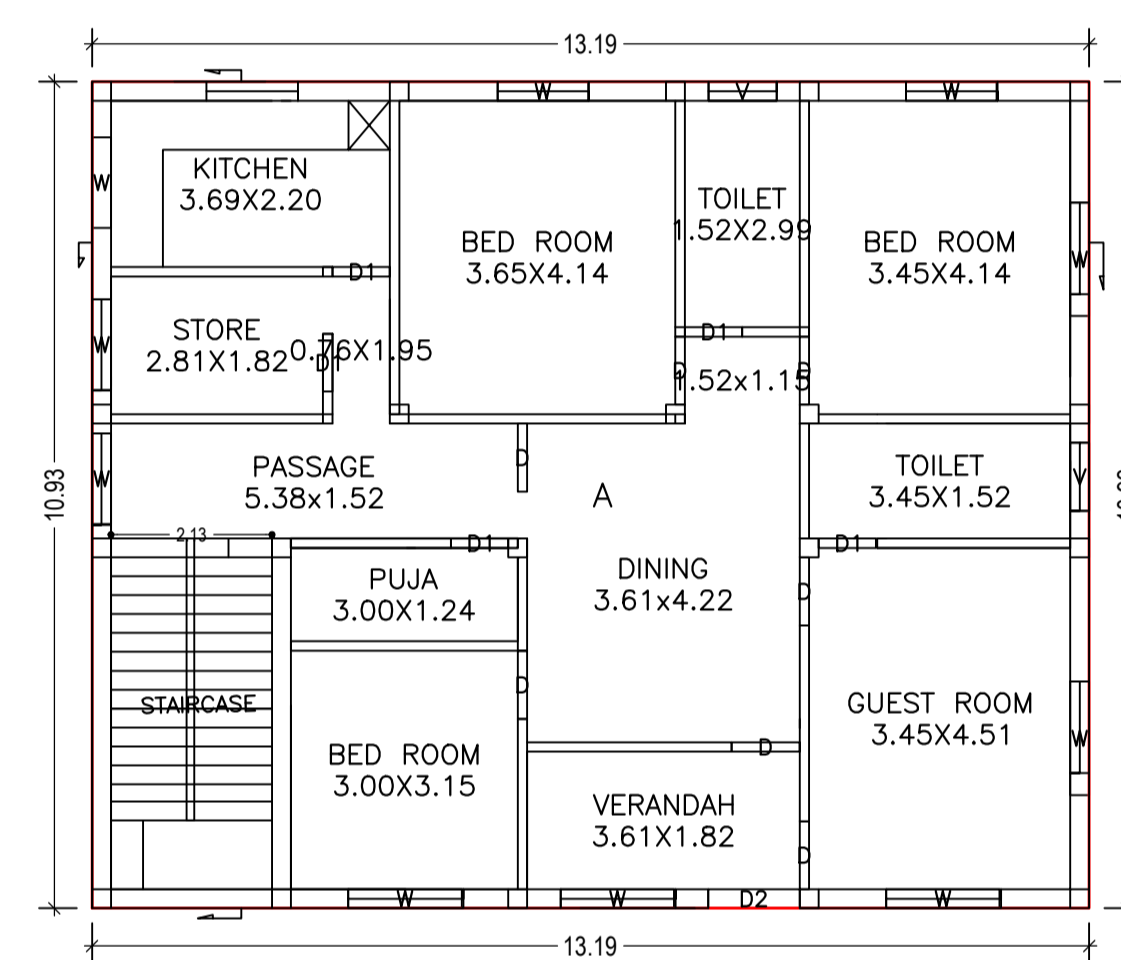

GROUND FLOOR PLAN (Proposed) (SCALE 1:100)

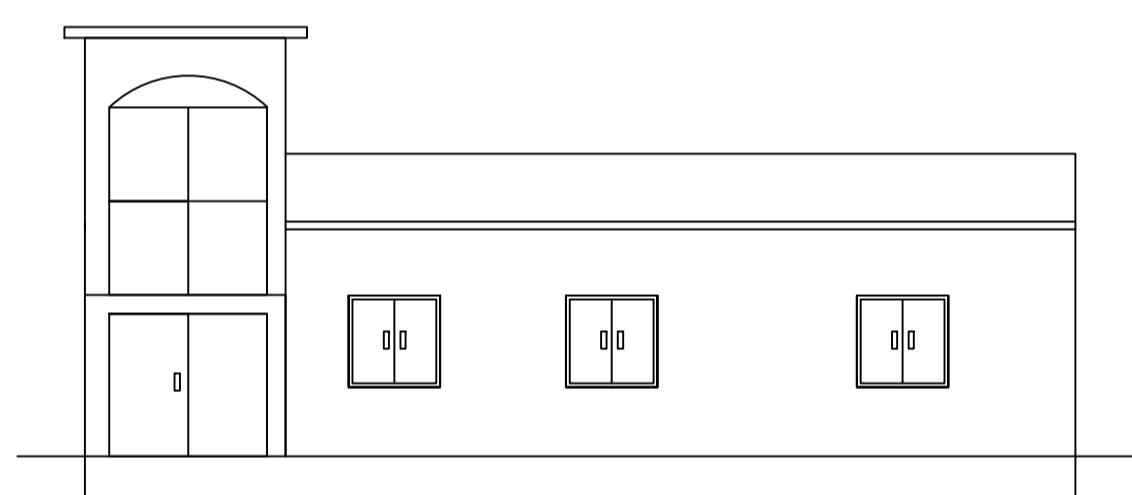

FRONT ELEVATION

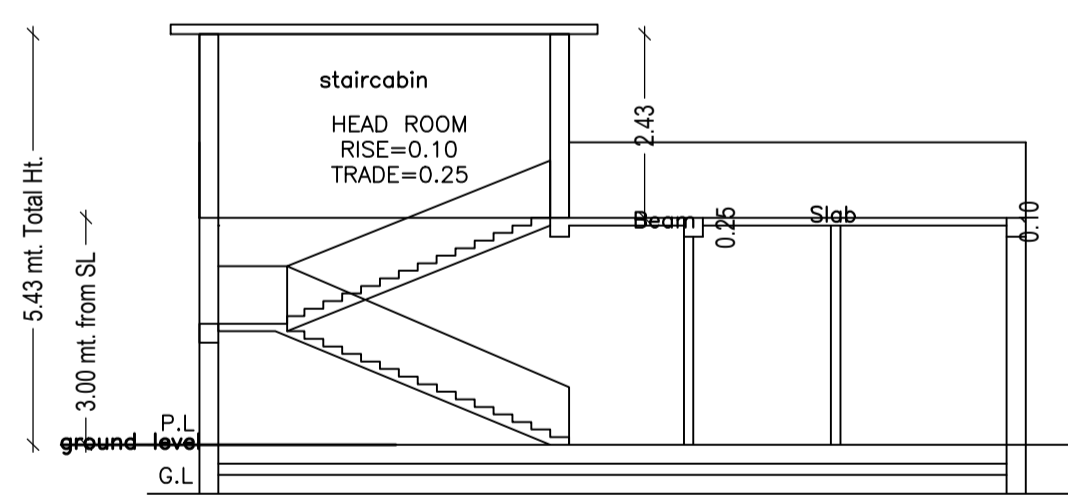

SECTION ON-XX

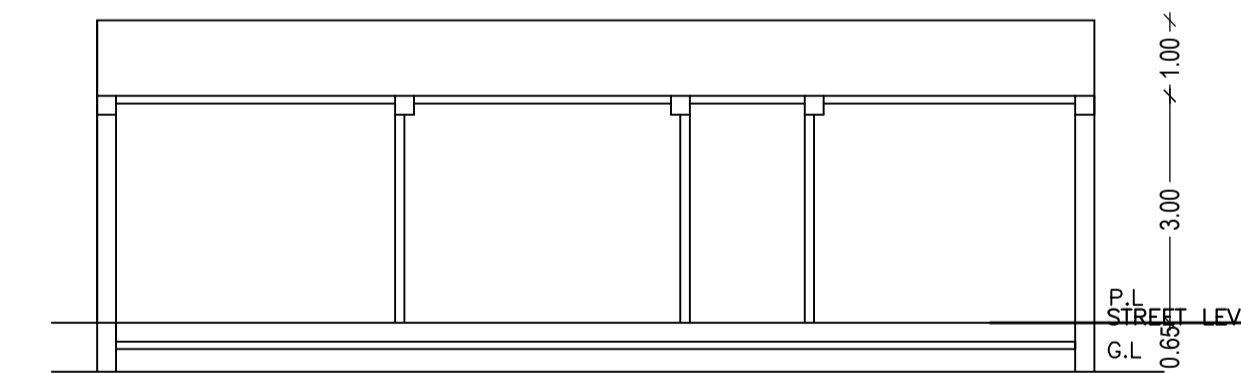

SECTION ON-YY

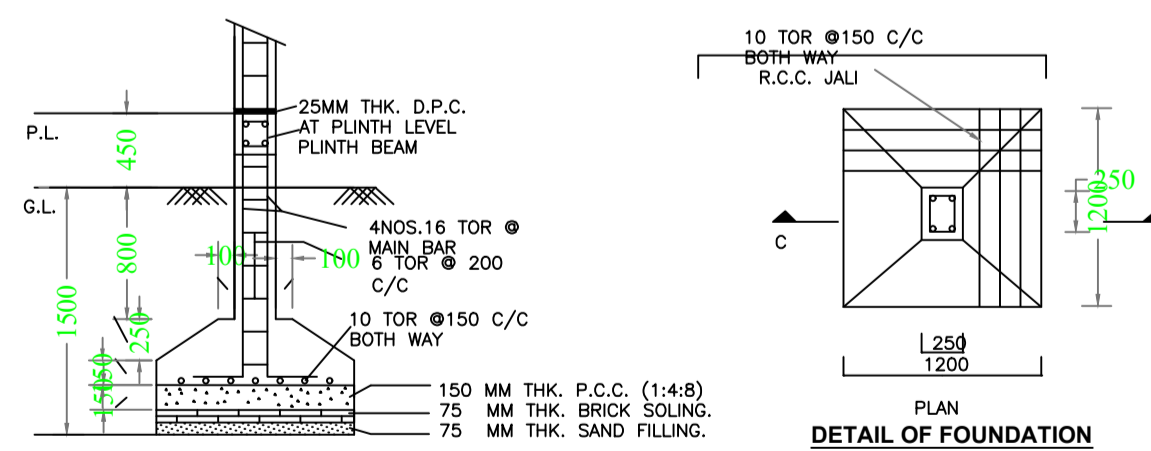

STRUCTURAL DETAIL

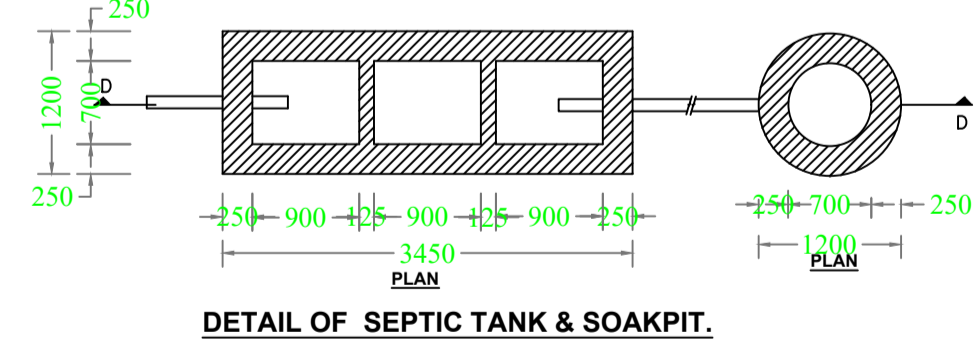

DETAIL OF SEPTIC TANK & SOAKPIT.

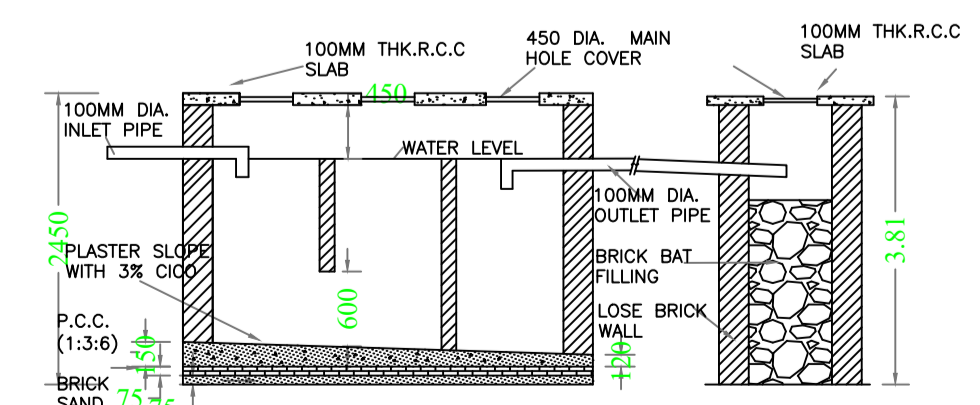

DETAIL OF FOOTING & COLUMN

Sl.No	L x E x D	Column Mark	Column Size	Column Reinf.
F1	1200x1200x150	C1	250x250	NO-14
F2	1200x1200x150	C1	250x250	NO-14

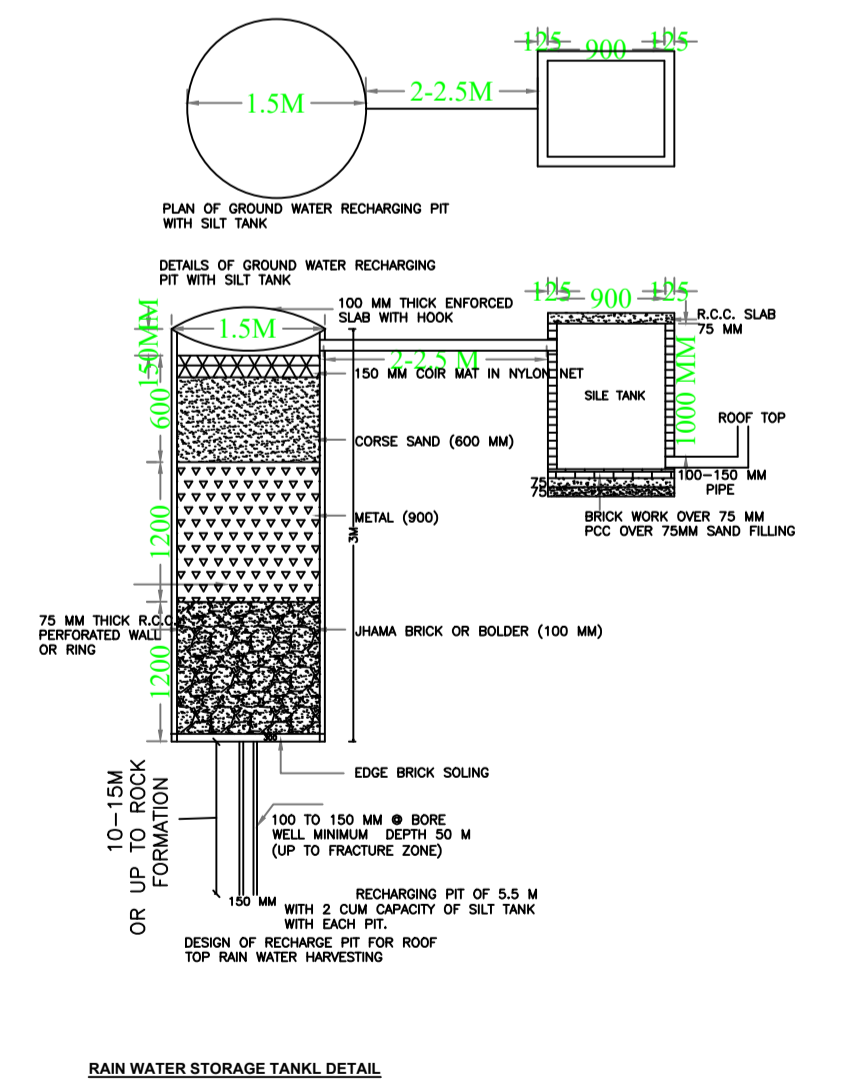

RAIN WATER STORAGE TANK DETAIL

LTP NAME AND SIGNATURE	STRUCTURAL ENG'S NAME AND SIGNATURE	BUILDER NAME AND SIGNATURE	DIGITAL SIGNATURE
RANJIT KUMAR MNNP/ENG/0001/2016			