

Proposal Basic Information	
Proposal File No.	MNNP/BP/0044/W04/2019
Owner Name	RAMLA DEVI
Khata No	244,271
Plot No	48,50
Village Name	Baralota Rodma
Use	Residential
SubUse	Bungalow/ Dwelling / Non Apartment

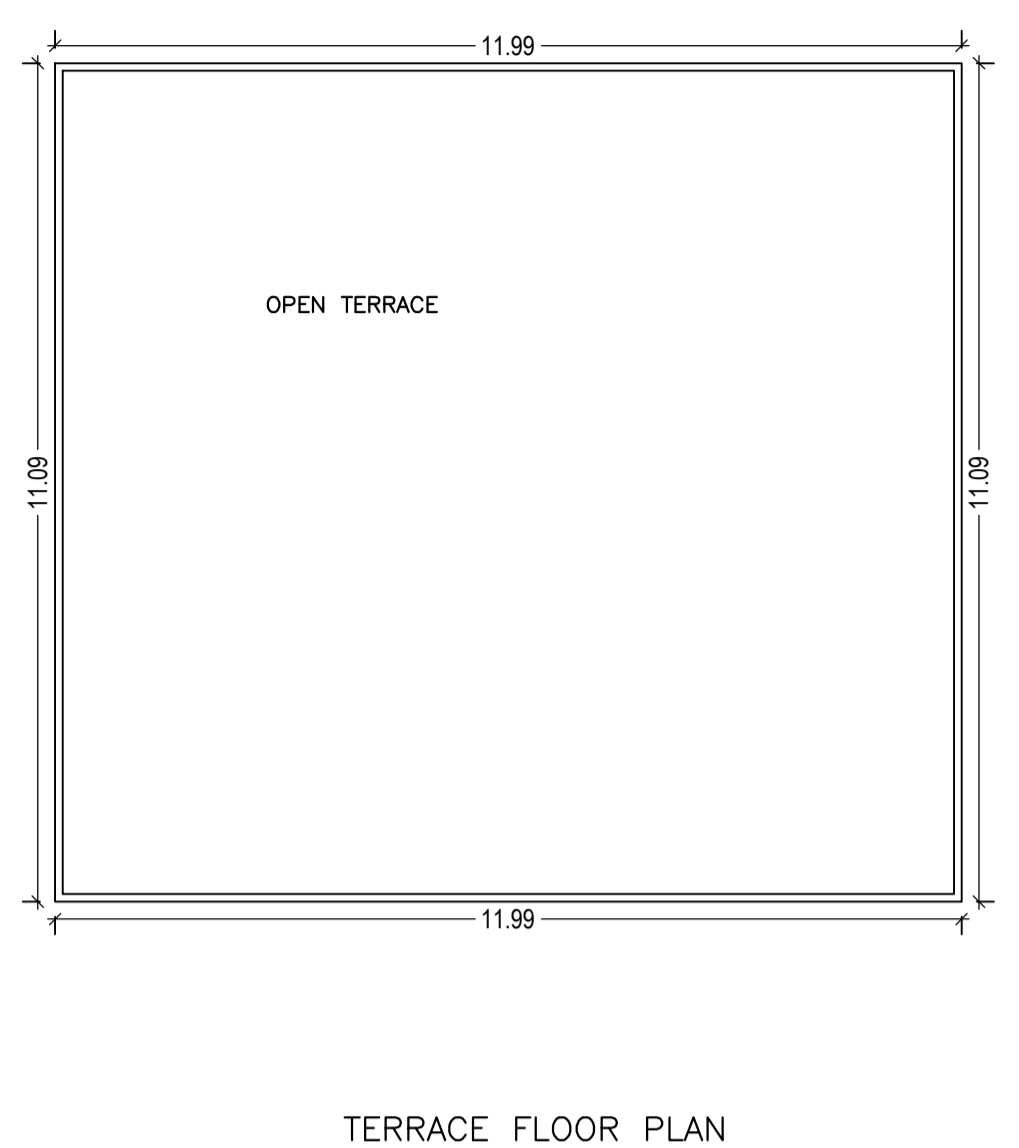
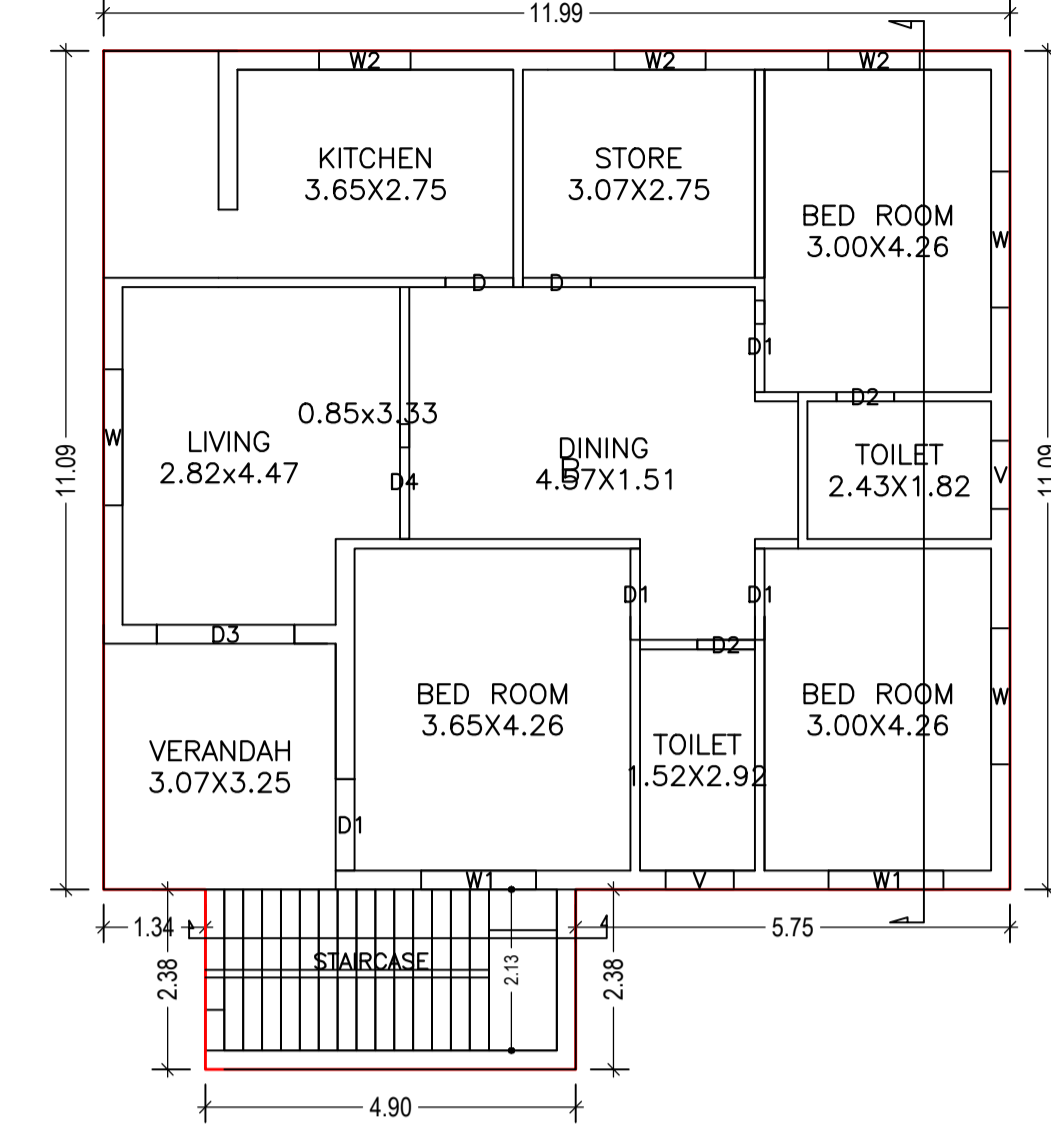
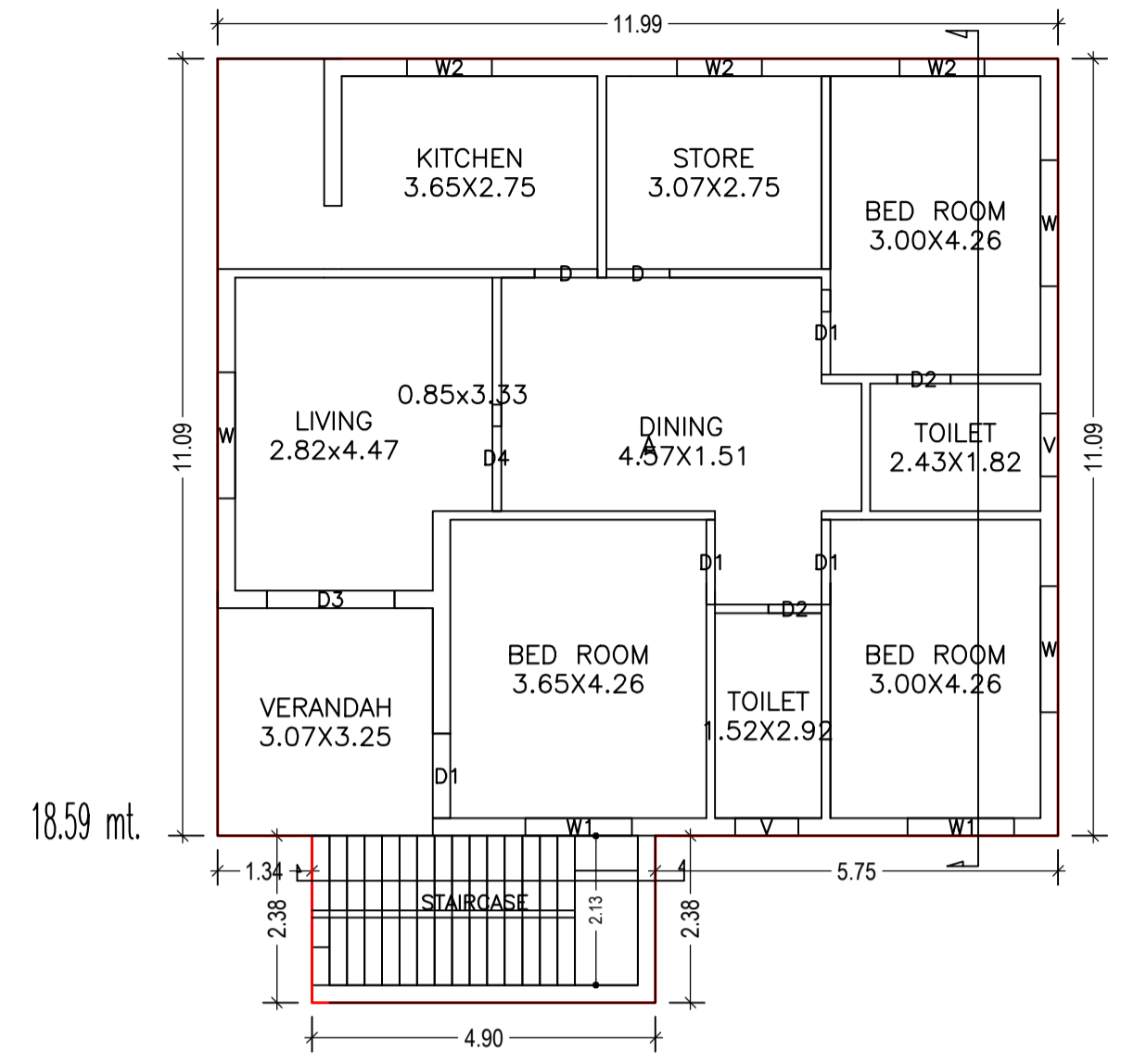
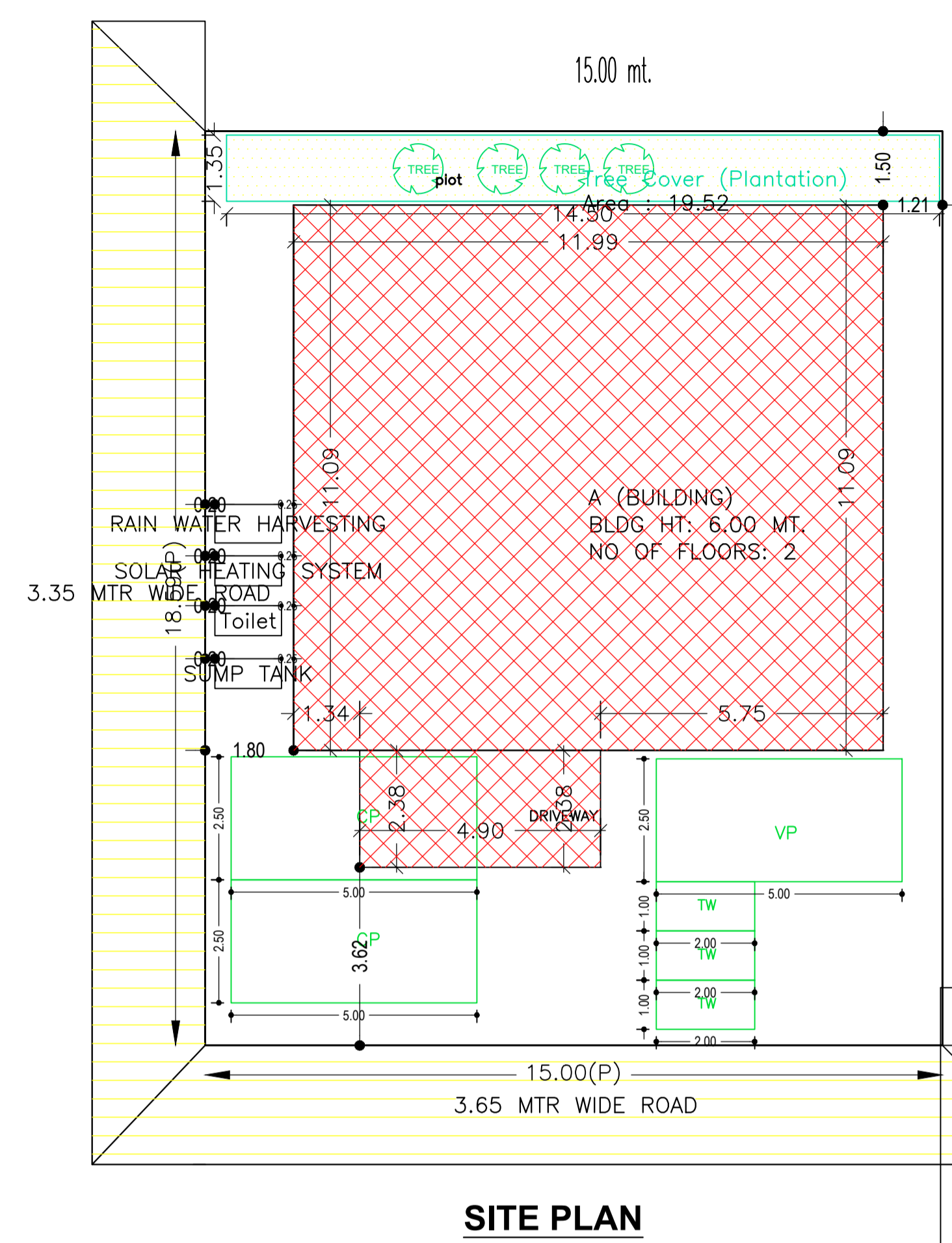

Required Parking (Table 7a)

Building Name	Type	SubUse	Area (Sq.mt.)		Units		Car		Visitors Car		TwoWheeler	
			Reqd.	Prop.	Reqd./Unit	Prop.	Reqd./Unit	Prop.	Reqd./Unit	Prop.	Reqd./Unit	Prop.
A (BUILDING)	Residential	Bungalow/ Dwelling / Non Apartment	>0	1	2.00	1	2	-	-	-	-	-
			>0	1	2.00	-	-	1	1	-	-	-
<b>Total:</b>			-	-	-	-	2	2	-	1	1	0

Parking Check (Table 7b)

Vehicle Type	Reqd.		Prop.	
	No.	Area	No.	Area
Car	-	-	2	25.00
Total Car	2	25.00	2	25.00
Visitor's Car Parking	-	-	1	12.50
Total Visitor Parking	1	12.50	1	12.50
TwoWheeler	-	-	3	6.00
Total TwoWheeler	-	-	3	6.00
<b>Total</b>		37.50		62.00

Building :A (BUILDING)

Floor Name	Total Built Up Area (Sq.mt.)	Proposed FAR Area (Sq.mt.)	Total FAR Area (Sq.mt.)	Total Consumed Additional FAR Area (Sq.mt.)	Tnmt (No.)
Ground Floor	144.63	144.63	144.63	144.63	01
First Floor	144.63	144.63	144.63	144.63	01
Terrace Floor	0.00	0.00	0.00	0.00	00
<b>Total:</b>	289.26	289.26	289.26	289.26	02
Total Number of Same Buildings	1				
<b>Total:</b>	289.26	289.26	289.26	289.26	02

SCHEDULE OF DOOR:

BUILDING NAME	NAME	LENGTH	HEIGHT	NOS
A (BUILDING)	D2	0.76	2.10	04
A (BUILDING)	D	0.90	2.10	04
A (BUILDING)	D1	1.21	2.10	08
A (BUILDING)	D4	1.52	2.10	02
A (BUILDING)	D3	1.82	2.10	02

SCHEDULE OF WINDOW/VENTILATION:

BUILDING NAME	NAME	LENGTH	HEIGHT	NOS
A (BUILDING)	V	0.90	0.60	04
A (BUILDING)	W2	1.21	1.20	06
A (BUILDING)	W1	1.52	1.20	04
A (BUILDING)	W	1.80	1.20	06

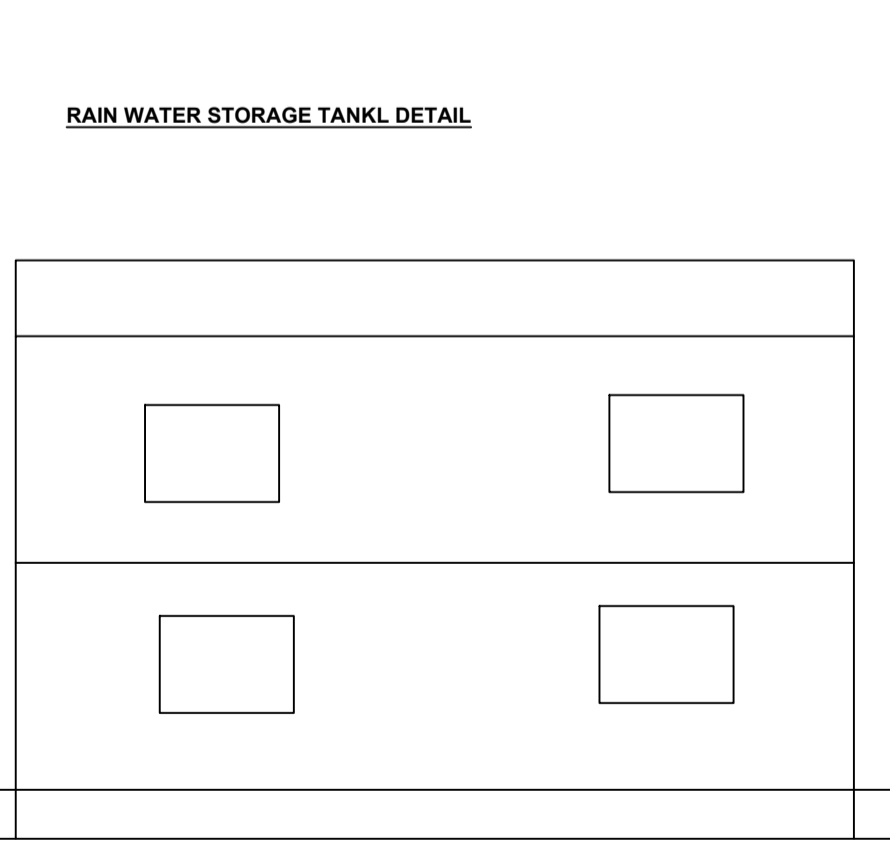
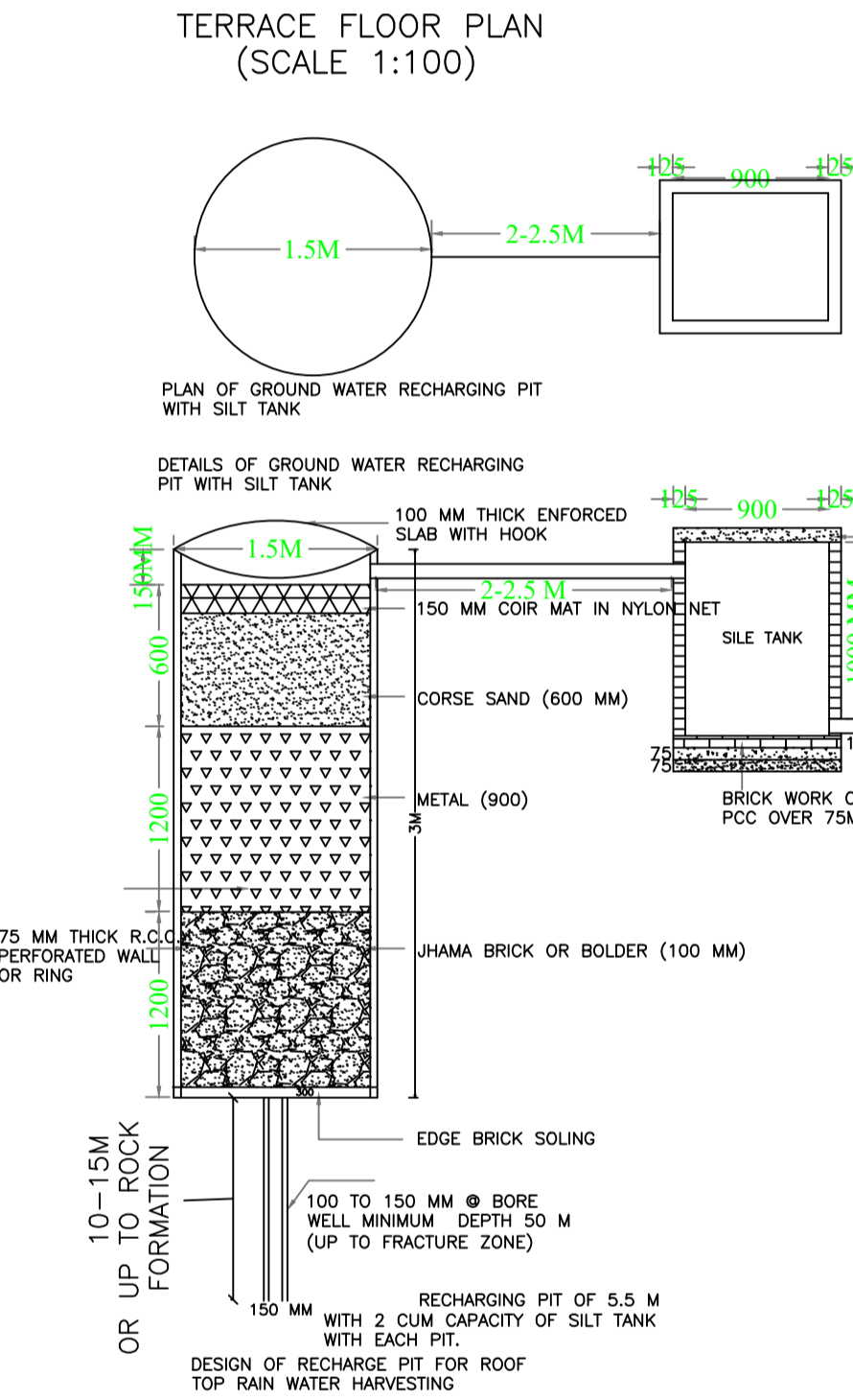
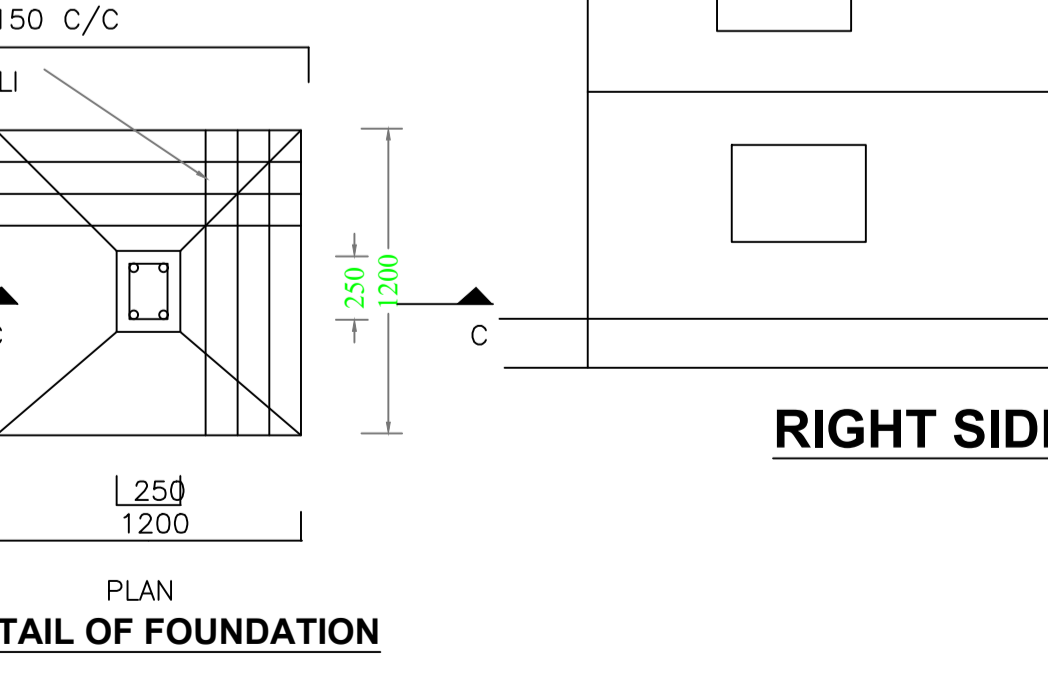
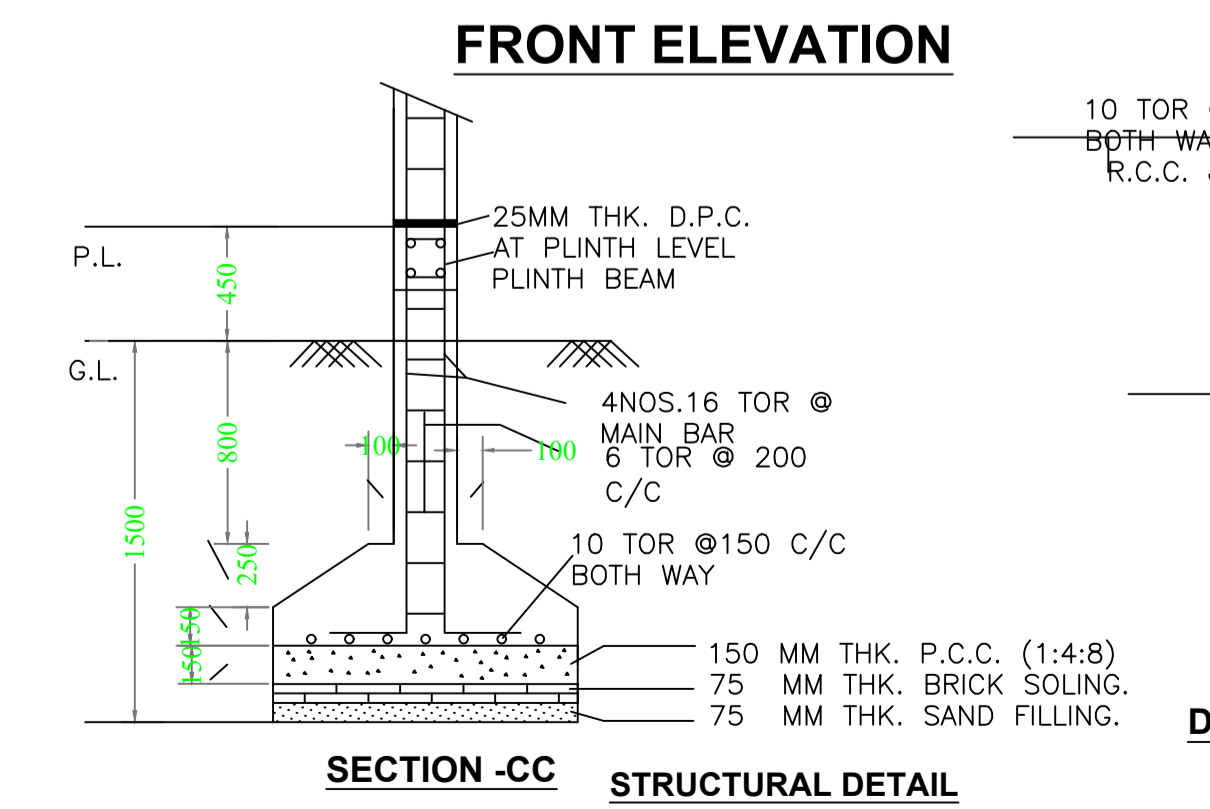
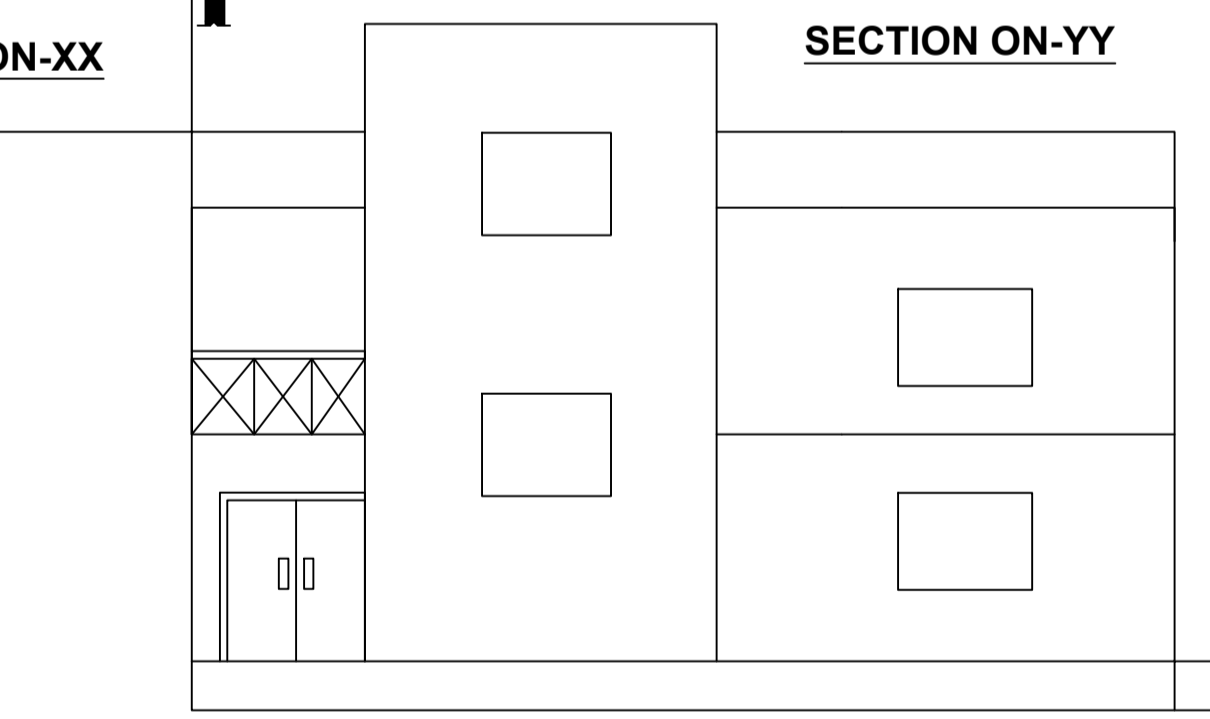
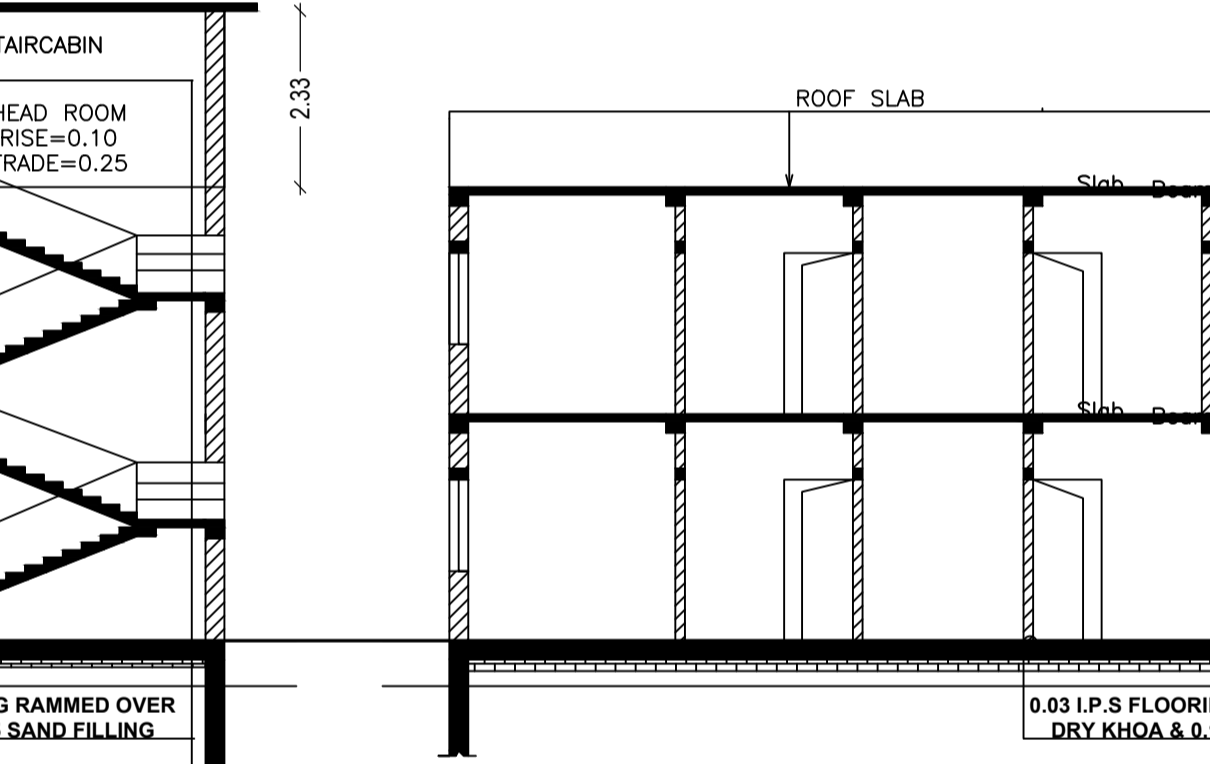
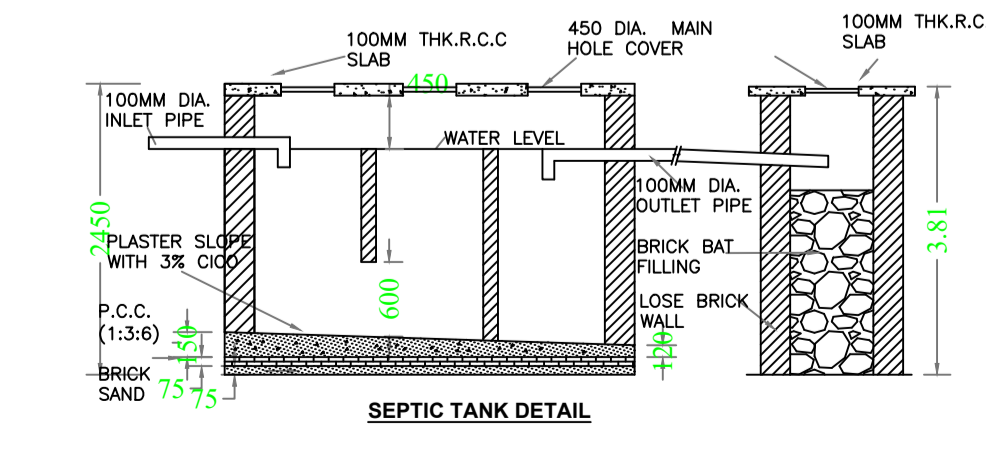
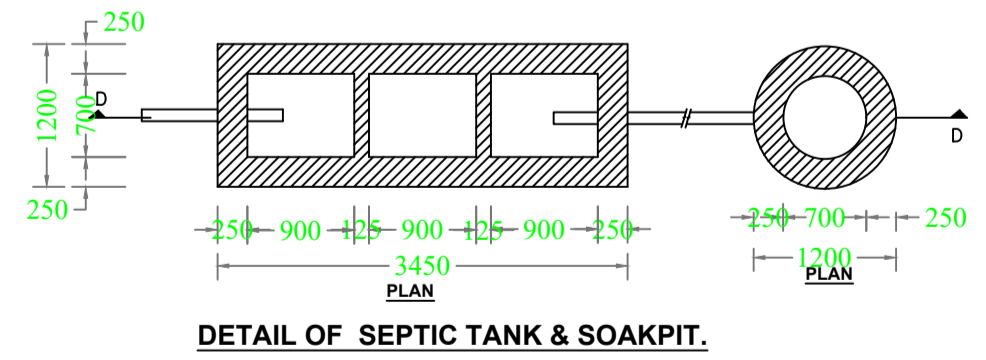

AREA STATEMENT		VERSION NO.:	1.0.37
MEDININAGAR NAGAR PARISHAD		VERSION DATE: 29/04/2019	
PROJECT DETAIL:			
Region: JHARKHAND URBAN	Plot Use: Residential		
LOCAL BODIES: District: PALAMU	Plot SubUse: Bungalow/ Dwelling / Non Apartment		
Authority: MEDININAGAR NAGAR PARISHAD	PlotNearby/ReligiousStructure: NA		
Inward_No: MNNP/BP/0044/W04/2019	Plot/SubPlot No: 48,50		
Application Type: General Proposal	North: -		
Project Type: Building Permission	South: -		
Nature of Development: New	East: -		
Location of Development Area: Old Area	West: -		
AREA DETAILS:			
AREA OF PLOT (Minimum)	(A)		SQ.MT.
NET AREA OF PLOT (Gross Plot Area - Deduction from Gross Plot area)	(A-Deductions)		278.85
Deduction for Balance Plot Area (from Gross Plot Area)			
Common Plot			19.52
Total			19.52
BALANCE AREA OF PLOT (Net Plot Area - Recreational/Amenity space)	(A-Deductions)		259.33
PLOT AREA FOR COVERAGE (Net Plot Area)	(A-Deductions)		278.85
Plot Area for FAR (Net Plot Area + Road/Widening Area)	(A-Deductions)		278.85
COVERAGE CHECK			
Permissible Coverage area (60.00 %)			167.31
Proposed Coverage Area (51.87 %)			144.63
Total Prop. Coverage Area (51.87 %)			144.63
Balance coverage area (8.13 %)			22.68
FAR CHECK			
Perm. FAR Area (1.50)			418.28
Total Perm. FAR area			418.28
Residential FAR			289.26
Proposed FAR Area			289.26
Total Proposed FAR Area			289.26
Consumed FAR (Factor)			1.04
Balance FAR Area			129.02
BUILT UP AREA CHECK			
Total Proposed BuiltUp Area			289.26
ARCHITECT (Regd) RANJIT KUMAR			
ENGINEER (Regd)			
SUPERVISOR (Regd)			
OWNER (Regd) RAMLA DEVI			
DEVELOPMENT AUTHORITY		LOCAL BODY	

COLOR INDEX	
PLOT BOUNDARY	Black
ABUTTING ROAD	Red
PROPOSED CONSTRUCTION	Green
COMMON PLOT	Yellow
ROAD WIDENING AREA	Blue
EXISTING (To be retained)	Orange
EXISTING (To be demolished)	Purple

Floor Name	Building Name		Total	
	Proposed Built Up Area (Sq.mt.)	Proposed FAR Area (Sq.mt.)	Total Proposed Built Up Area (Sq.mt.)	Total FAR Area (Sq.mt.)
Ground Floor	144.63	144.63	144.63	144.63
First Floor	144.63	144.63	144.63	144.63
Terrace Floor	0.00	0.00	0.00	0.00
<b>Total:</b>	289.26	289.26	289.26	289.26

Building USE/SUBUSE Details			
Building Name	Building Use	Building SubUse	Building Structure
A (BUILDING)	Residential	Bungalow/ Dwelling / Non Apartment	Non-Highrise

FAR & Tenement Details (Table 4c-1)						
Building	No. of Same Bldg	Total Built Up Area (Sq.mt.)	Proposed FAR Area (Sq.mt.)	Total FAR Area (Sq.mt.)	Total Consumed Additional FAR Area (Sq.mt.)	Tnmt (No.)
A (BUILDING)	1	289.26	289.26	289.26	289.26	02
<b>Grand Total:</b>	1	289.26	289.26	289.26	289.26	02

UnitBUA Table for Building :A (BUILDING)						
FLOOR	Name	UnitBUA Type	UnitBUA Area	Carpet Area	No. of Rooms	No. of Tenement
GROUND FLOOR PLAN	A	FLAT	128.41	128.07	10	1
FIRST FLOOR PLAN	B	FLAT	128.41	128.07	10	1
<b>Total:</b>	-	-	256.82	256.14	20	2

LTP NAME AND SIGNATURE	STRUCTURAL ENG'S NAME AND SIGNATURE	BUILDER NAME AND SIGNATURE	DIGITAL SIGNATURE
RANJIT KUMAR MNNP/ENG/0001/2016			