

Proposal Basic Information	
Proposal File No.	MNNP/BP/0054/W15/2021
Owner Name	chandrashekher kumar
Khata No	123
Plot No	160
Village Name	Baralota Rodma
Use	Residential
SubUse	Bungalow/ Dwelling / Non Apartment

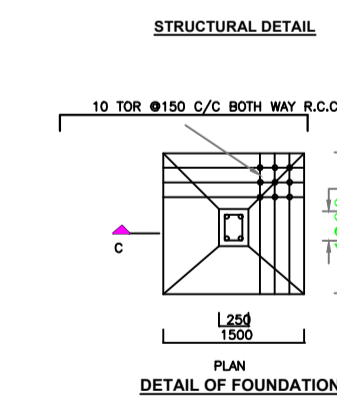
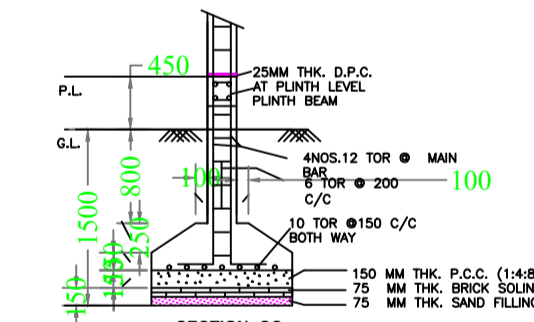
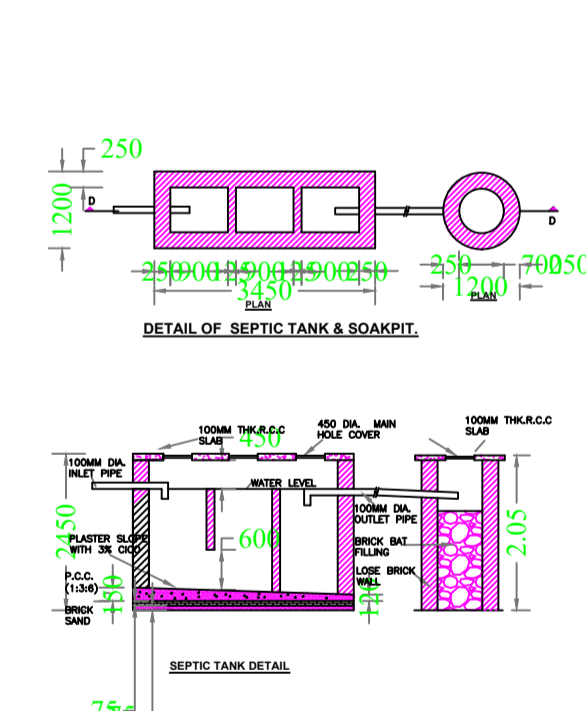
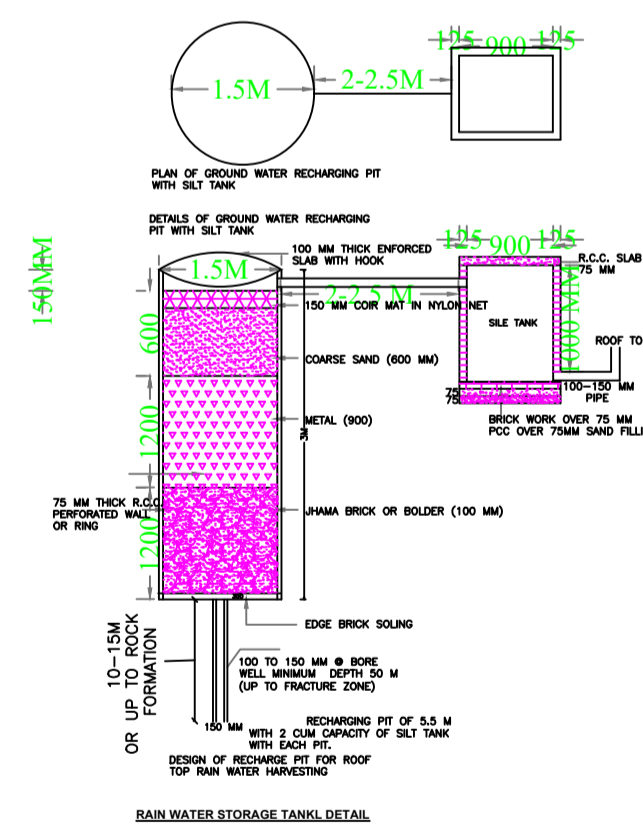
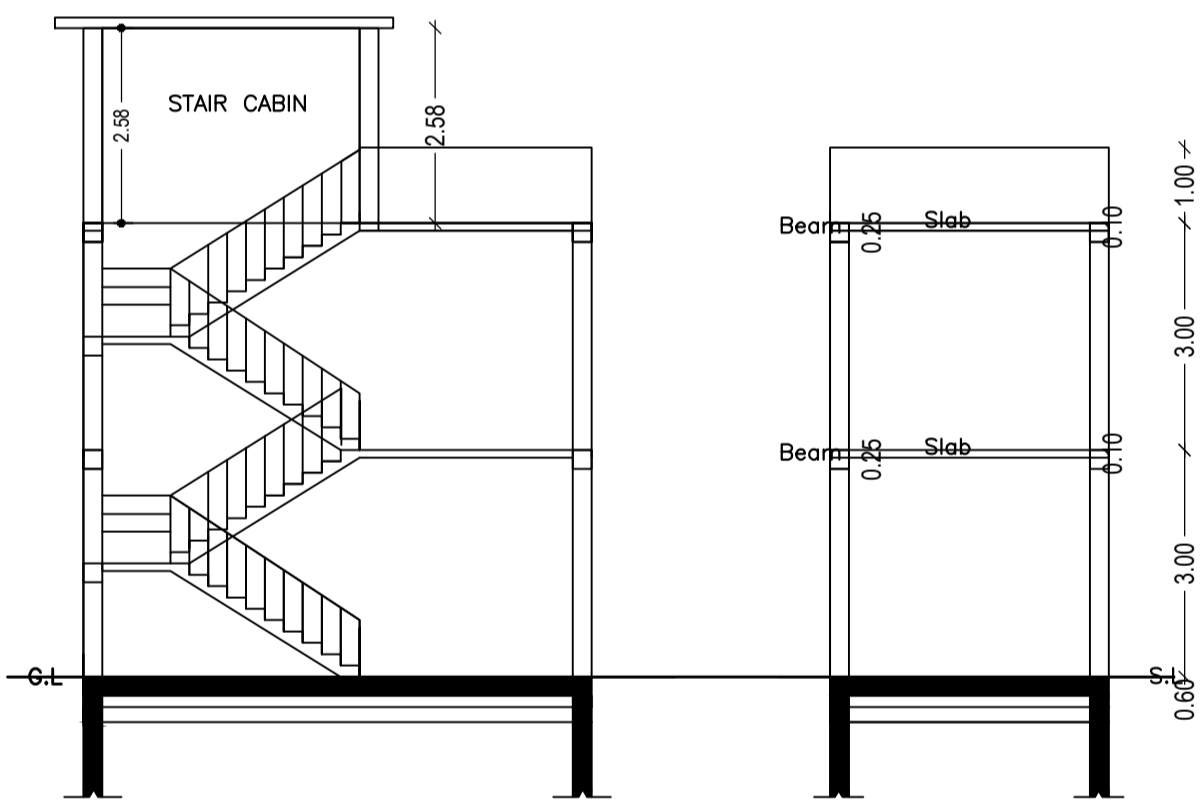
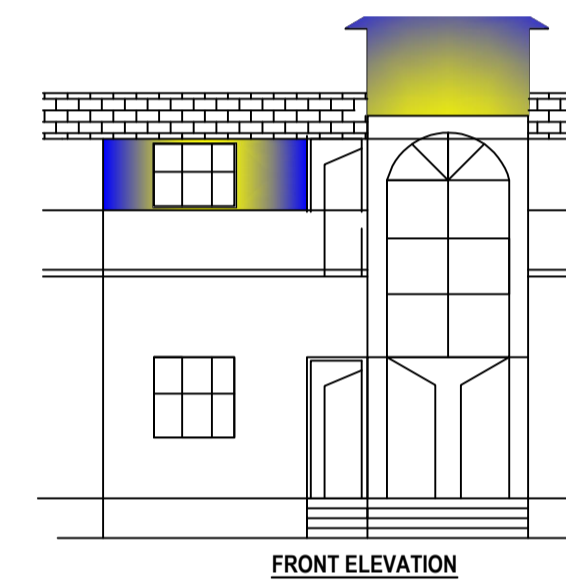
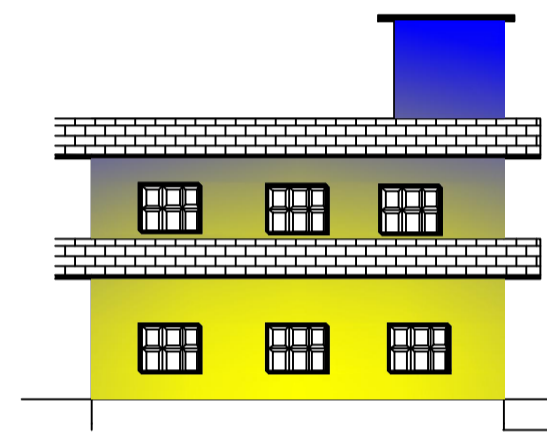
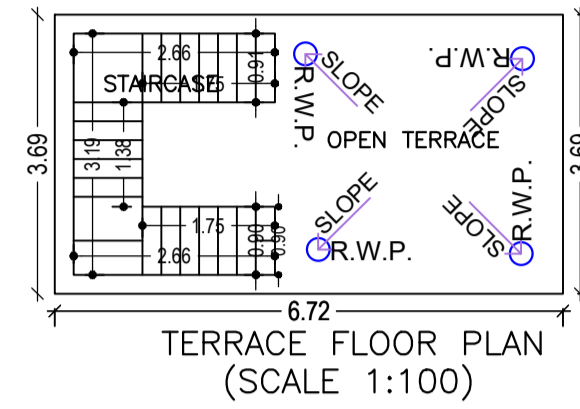
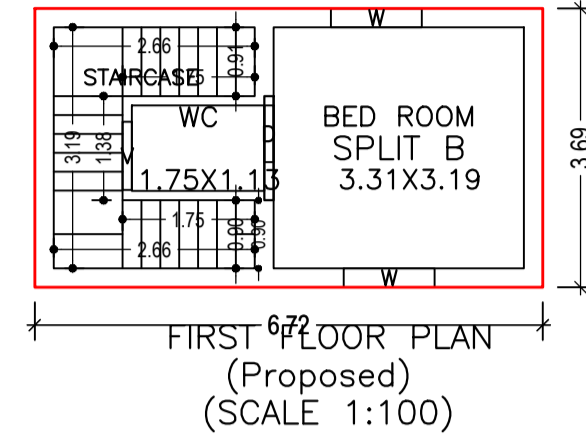
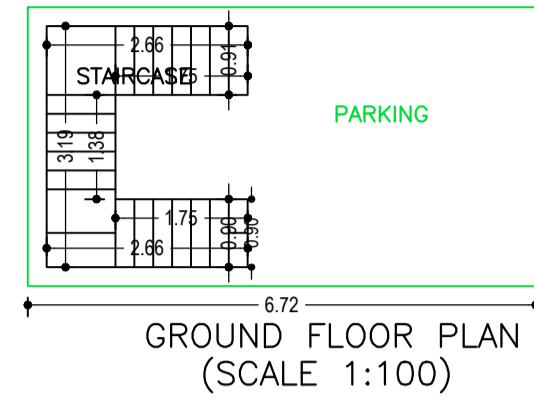
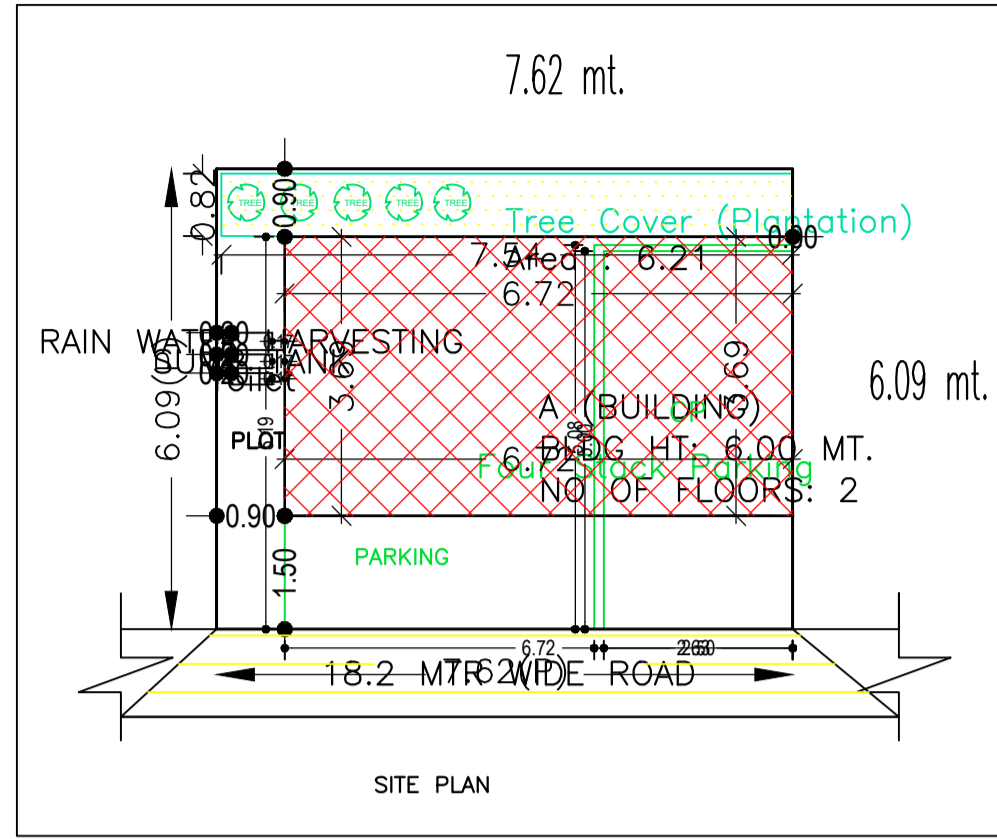

Building :A (BUILDING)

Floor Name	Total Built Up Area (Sq.mt.)	Deductions (Area in Sq.mt.)		Proposed FAR Area (Sq.mt.)	Add Area In FAR (Sq.mt.)	Total FAR Area (Sq.mt.)	Total Consumed Additional FAR Area (Sq.mt.)	Trmt (No.)
		Parking	Resi.					
Ground Floor	24.80	18.73	0.00	6.07	6.07	6.07	0.00	
First Floor	24.80	0.00	24.80	0.00	24.80	24.80	0.01	
Terrace Floor	0.00	0.00	0.00	0.00	0.00	0.00	0.00	
Total :	49.60	18.73	24.80	6.07	30.87	30.87	0.01	

SCHEDULE OF DOOR:

BUILDING NAME	NAME	LENGTH	HEIGHT	NOS
A (BUILDING)	D	0.75	2.10	01

SCHEDULE OF WINDOW/VENTILATION:

BUILDING NAME	NAME	LENGTH	HEIGHT	NOS
A (BUILDING)	V	0.90	1.20	01
A (BUILDING)	W	1.20	1.20	02

UnitBUA Table for Building :A (BUILDING)

FLOOR	Name	UnitBUA Type	UnitBUA Area	Carpet Area	No. of Rooms	No. of Tenement
FIRST FLOOR PLAN	SPLIT B	FLAT	16.47	16.30	2	1
Total:	-	-	16.47	16.30	2	1

AREA STATEMENT		VERSION NO. : 1.0.55
MEDINAGAR MUNICIPAL CORPORATION		VERSION DATE: 16/10/2020
PROJECT DETAIL:		
Region: JHARKHAND URBAN LOCAL BODIES	Plot Use: Residential	
District: PALAMU	Plot SubUse: Bungalow/ Dwelling / Non Apartment	
Authority: MEDINAGAR MUNICIPAL CORPORATION	PlotNearbyReligiousStructure: NA	
Inward_No: MNNP/BP/0054/W15/2021	Plot/SubPlot No: 160	
Application Type: General Proposal	North: -	
Project Type: Building Permission	South: -	
Nature of Development: New	East: -	
Location of Development Area: Old Area	West: -	
AREA DETAILS:		
AREA OF PLOT (Minimum)	(A)	SQ.MT. 46.41
NET AREA OF PLOT(Gross Plot Area - Deduction from Gross Plot area)	(A-Deductions)	46.41
Deduction for Balance Plot Area(from Gross Plot Area)		
Common Plot		6.21
Total		6.21
BALANCE AREA OF PLOT(Net Plot Area - Recreational/Amenity space)	(A-Deductions)	40.20
PLOT AREA FOR COVERAGE(Net Plot Area)	(A-Deductions)	46.41
Plot Area for FAR (Net Plot Area + RoadWidening Area)	(A-Deductions)	46.41
COVERAGE CHECK		
Permissible Coverage area (70.00 %)		32.49
Proposed Coverage Area (53.44 %)		24.80
Total Prop. Coverage Area (53.44 %)		24.80
Balance coverage area (16.57 %)		7.69
FAR CHECK		
Perm. FAR Area (2.50)		116.03
Total Perm. FAR area		116.03
Residential FAR		24.80
Proposed FAR Area		30.87
Total Proposed FAR Area		30.87
Consumed FAR (Factor)		0.67
Balance FAR Area		85.16
BUILT UP AREA CHECK		
Total Proposed BuiltUp Area		49.60
ARCHITECT (Regd)		RANJIT KUMAR
ENGINEER (Regd)		
SUPERVISOR (Regd)		
OWNER (Regd)		chandrashekher kumar
DEVELOPMENT AUTHORITY		LOCAL BODY

COLOR INDEX	
PLOT BOUNDARY	Black
ABUTTING ROAD	Green
PROPOSED CONSTRUCTION	Red
COMMON PLOT	Yellow
ROAD WIDENING AREA	Blue
EXISTING (To be retained)	Light Blue
EXISTING (To be demolished)	Dark Blue

Buildingwise Floor FAR Details

Floor Name	Building Name A (BUILDING)		Total	
	Proposed Built Up Area (Sq.mt.)	Proposed FAR Area (Sq.mt.)	Total Proposed Built Up Area (Sq.mt.)	Total FAR Area (Sq.mt.)
Ground Floor	24.80	6.07	24.80	6.07
First Floor	24.80	24.80	24.80	24.80
Terrace Floor	0.00	0.00	0.00	0.00
Total :	49.60	30.87	49.60	30.87

Building USE/SUBUSE Details

Building Name	Building Use	Building SubUse	Building Structure
A (BUILDING)	Residential	Bungalow/ Dwelling / Non Apartment	Non-Highrise

FAR & Tenement Details (Table 4c-1)

Building	No. of Same Bldg	Total Built Up Area (Sq.mt.)	Deductions (Area in Sq.mt.)		Proposed FAR Area (Sq.mt.)	Add Area In FAR (Sq.mt.)	Total FAR Area (Sq.mt.)	Total Consumed Additional FAR Area (Sq.mt.)	Trmt (No.)
			Parking	Resi.					
A (BUILDING)	1	49.60	18.73	24.80	6.07	30.87	30.87	0.01	
Grand Total :	1	49.60	18.73	24.80	6.07	30.87	30.87	0.01	

LTP NAME AND SIGNATURE	STRUCTURAL ENG'S NAME AND SIGNATURE	BUILDER NAME AND SIGNATURE	DIGITAL SIGNATURE
RANJIT KUMAR MNNP/ENG/0001/2016			