

Proposal Basic Information	
Proposal File No.	MNNP/BP/0171/W18/2021
Owner Name	PUSHPA DEVI
Khata No	103
Plot No	148
Village Name	Baralota Rodma
Use	Residential
SubUse	Bungalow/ Dwelling / Non Apartment

AREA STATEMENT		VERSION NO. : 1.0.62
MEDININAGAR MUNICIPAL CORPORATION		VERSION DATE: 16/10/2020
PROJECT DETAIL:		
Region: JHARKHAND URBAN LOCAL BODIES	Plot Use: Residential	
District: PALAMU	Plot SubUse: Bungalow/ Dwelling / Non Apartment	
Authority: MEDININAGAR MUNICIPAL CORPORATION	PlotNearby/ReligiousStructure: NA	
Inward No: MNNP/BP/0171/W18/2021	Plot/SubPlot No: 148	
Application Type: General Proposal	North: -	
Project Type: Building Permission	South: -	
Nature of Development: New	East: -	
Location of Development Area: Old Area	West: -	
AREA DETAILS:		
AREA OF PLOT (Minimum)	(A)	SQ.MT. 470.70
NET AREA OF PLOT(Gross Plot Area - Deduction from Gross Plot area)		470.70
Deduction for Balance Plot Area(from Gross Plot Area)		
Common Plot		47.81
Total		47.81
BALANCE AREA OF PLOT(Net Plot Area - Recreational/Amenity space)	(A-Deductions)	422.89
PLOT AREA FOR COVERAGE(Net Plot Area)	(A-Deductions)	470.70
Plot Area for FAR (Net Plot Area - Road/Widening Area)	(A-Deductions)	470.70
COVERAGE CHECK		
Permissible Coverage area (60.00 %)		282.42
Proposed Coverage Area (38.79 %)		182.60
Total Prop. Coverage Area (38.79 %)		182.60
Balance coverage area (21.21 %)		99.62
FAR CHECK		
Perm. FAR Area (2.50)		1176.75
Total Perm. FAR area		1176.75
Residential FAR		895.53
Proposed FAR Area		895.53
Total Proposed FAR Area		895.53
Consumed FAR (Factor)		1.90
Balance FAR Area		281.22
BUILT UP AREA CHECK		
Total Proposed BuiltUp Area		913.00
ARCHITECT (Regd)	RANJIT KUMAR	
ENGINEER (Regd)		
SUPERVISOR (Regd)		
OWNER (Regd)	PUSHPA DEVI	
DEVELOPMENT AUTHORITY		LOCAL BODY

COLOR INDEX	
PLOT BOUNDARY	Black
ABUTTING ROAD	Red
PROPOSED CONSTRUCTION	Green
COMMON PLOT	Yellow
ROAD WIDENING AREA	Blue
EXISTING (To be retained)	Orange
EXISTING (To be demolished)	Purple

Floor Name	Building Name A (BUILDING)		Total	
	Proposed Built Up Area (Sq.mt.)	Proposed FAR Area (Sq.mt.)	Total Proposed Built Up Area (Sq.mt.)	Total FAR Area (Sq.mt.)
Ground Floor	182.60	182.60	182.60	182.60
First Floor	182.60	178.23	182.60	178.23
Second Floor	182.60	178.23	182.60	178.23
Third Floor	182.60	178.23	182.60	178.23
Fourth Floor	182.60	178.23	182.60	178.23
Terrace Floor	0.00	0.00	0.00	0.00
Total :	913.00	895.52	913.00	895.52

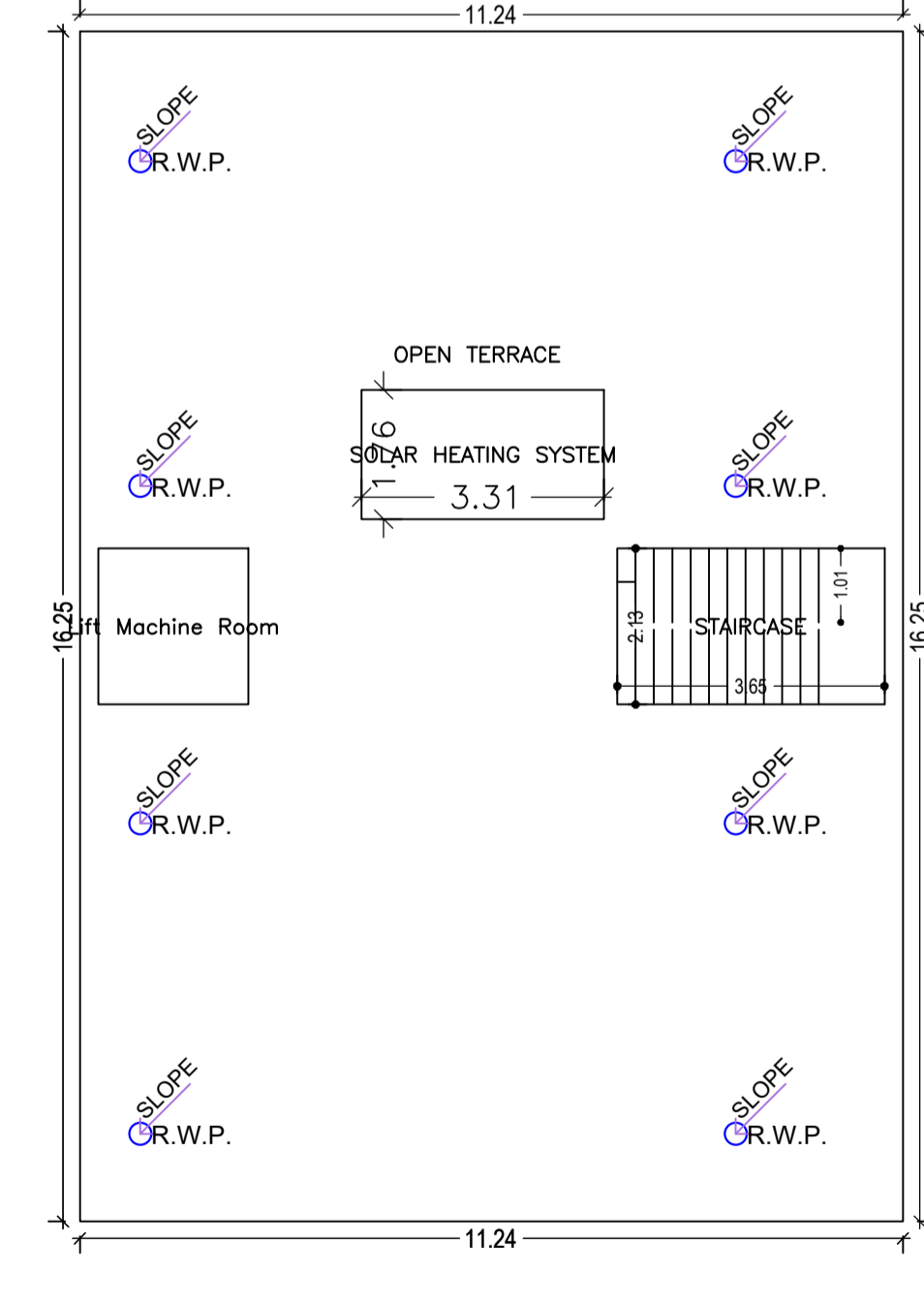
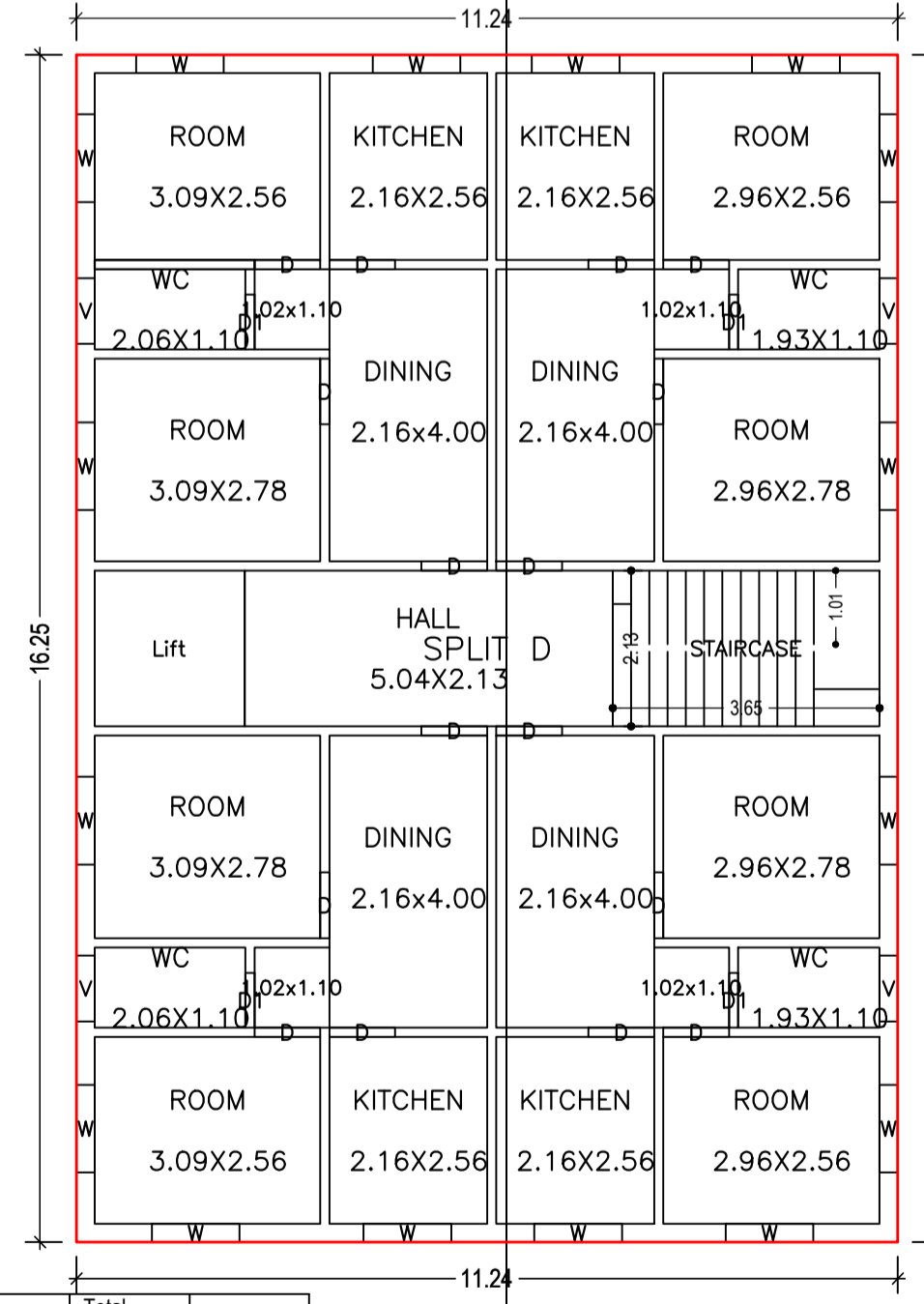
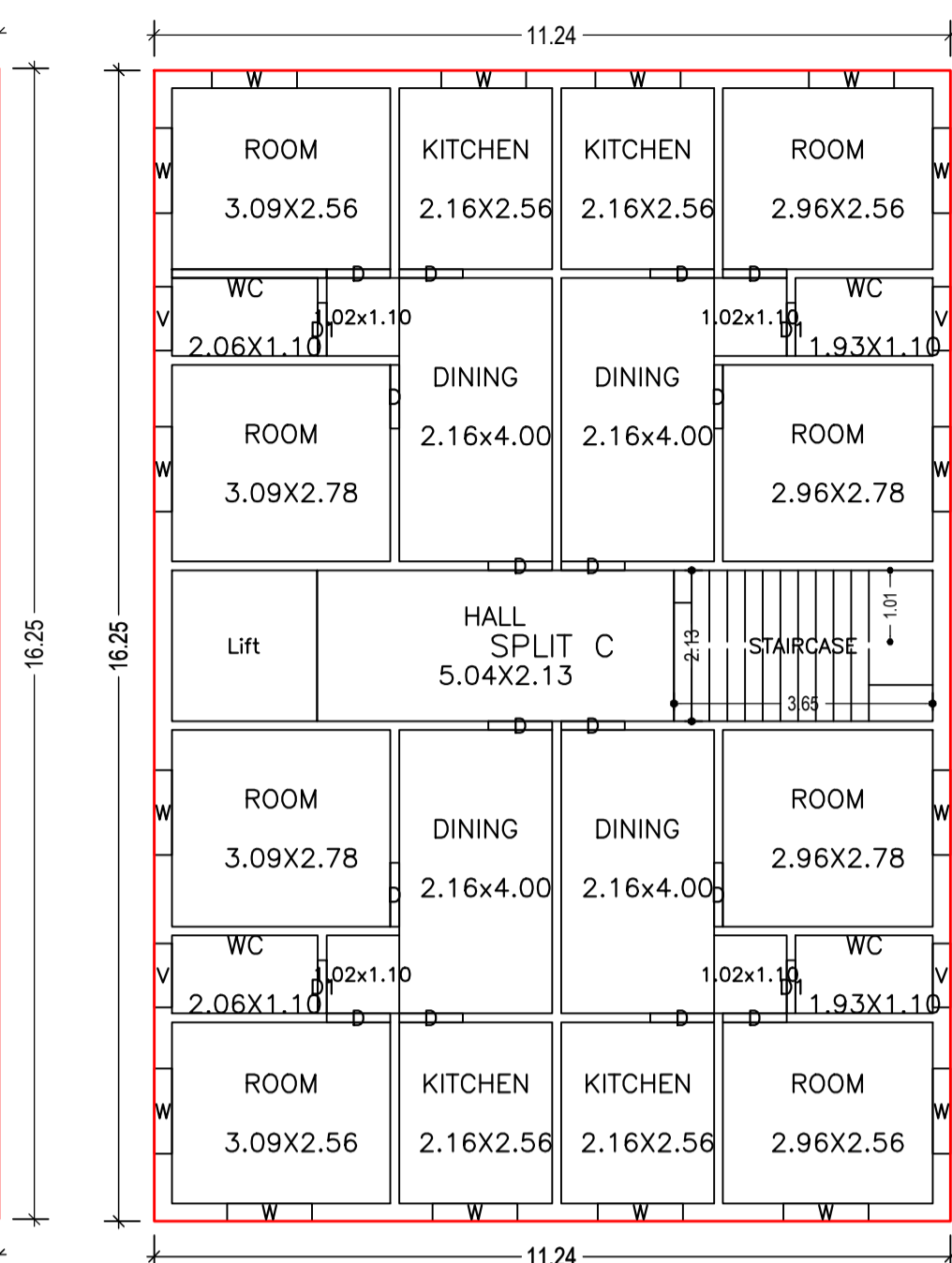
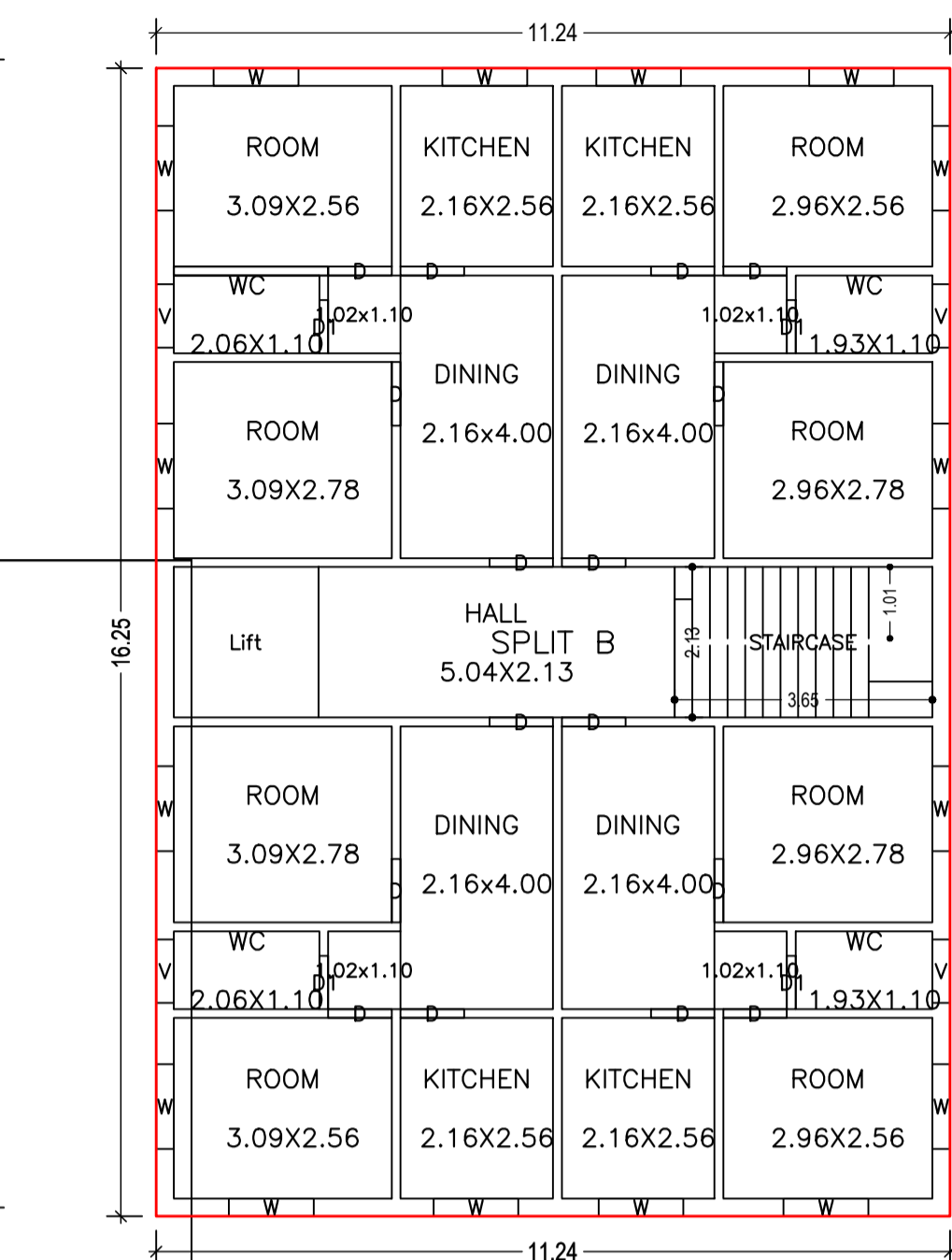
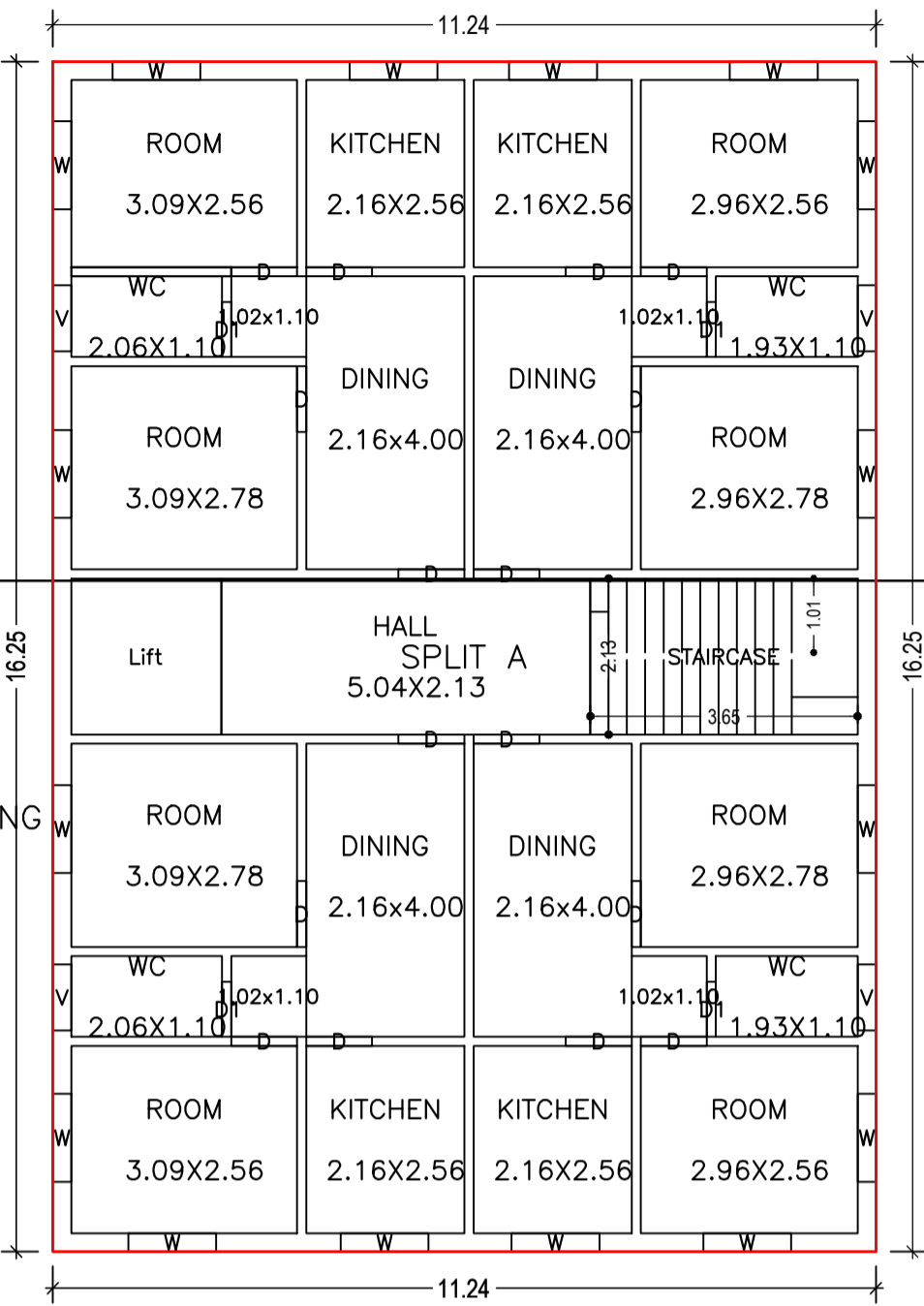
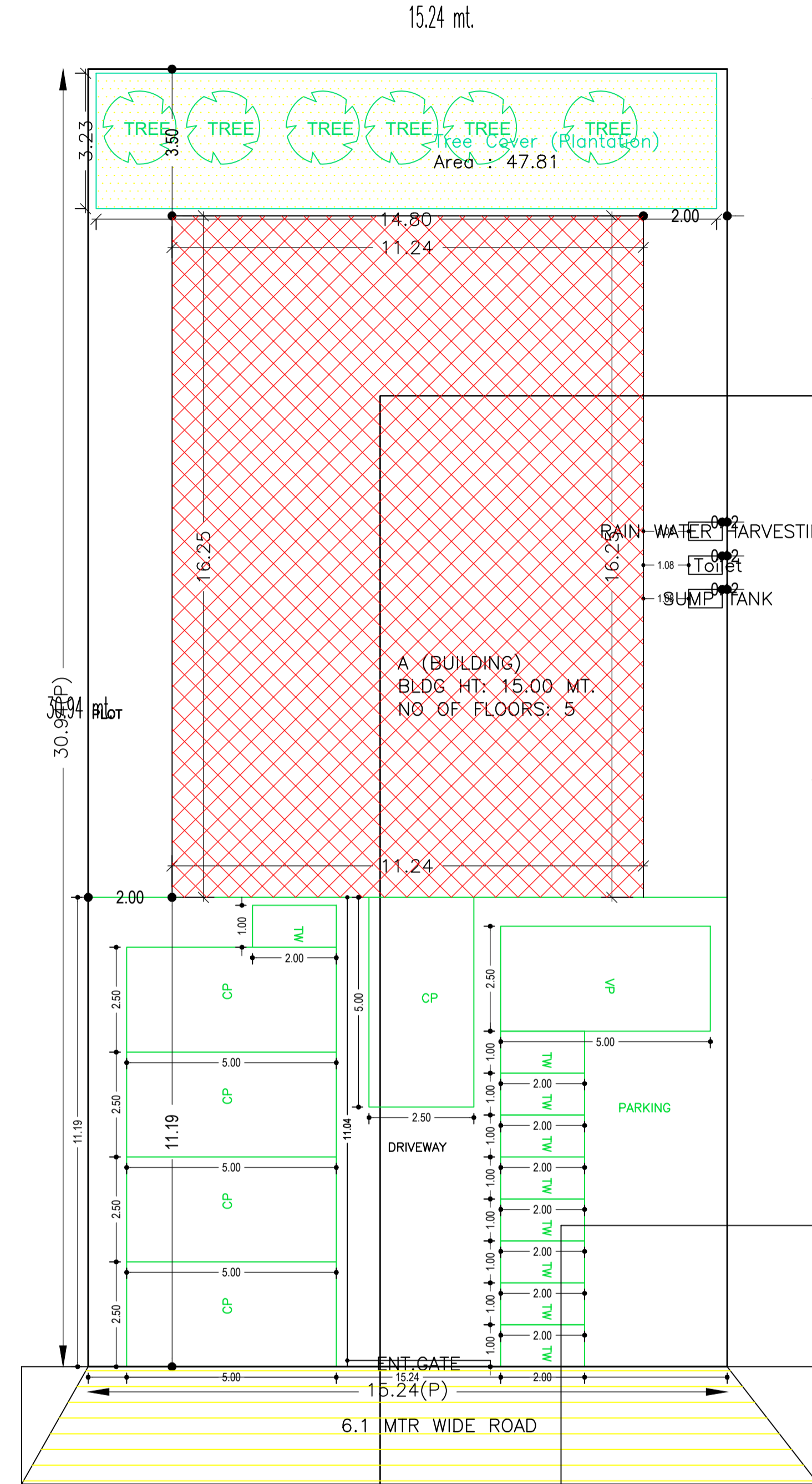

Building USE/SUBUSE Details

Building Name	Building Use	Building SubUse	Building Structure
A (BUILDING)	Residential	Bungalow/ Dwelling / Non Apartment	Non-Highrise

Required Parking (Table 7a)

Building Name	Type	SubUse	Area (Sq.mt.)	Units		Car		Visitors Car		TwoWheeler	
				Reqd.	Prop.	Reqd./Unit	Prop.	Reqd./Unit	Prop.	Reqd./Unit	Prop.
A (BUILDING)	Residential	Bungalow/ Dwelling / Non Apartment	> 0	1	5.00	1	5	-	-	-	-
			> 0	1	5.00	-	-	1	1	-	-
Total :			-	-	-	5	5	1	1	0	9

Parking Check (Table 7b)

Vehicle Type	Reqd.		Prop.	
	No.	Area	No.	Area
Car	-	-	5	62.50
Total Car	5	62.50	5	62.50
Visitor's Car Parking	-	-	1	12.50
Total Visitor Parking	1	12.50	1	12.50
TwoWheeler	-	-	9	18.00
Total TwoWheeler	-	-	9	18.00
Other Parking	-	-	-	77.54
Total	-	75.00	-	188.54

FAR & Tenement Details (Table 4c-1)

Building	No. of Same Bldg	Total Built Up Area (Sq.mt.)	Deductions (Area in Sq.mt.)		Proposed FAR Area (Sq.mt.)	Total FAR Area (Sq.mt.)	Total Consumed Additional FAR Area (Sq.mt.)	Tnmt (No.)
			Lift	Resi.				
A (BUILDING)	1	913.00	17.48	895.52	895.52	895.52	05	
Grand Total :	1	913.00	17.48	895.52	895.52	895.52	05	

Proposal Basic Information	
Proposal File No.	MNNP/BP/0171/W18/2021
Owner Name	PUSHPA DEVI
Khata No	103
Plot No	148
Village Name	Baralota Rodma
Use	Residential
SubUse	Bungalow/ Dwelling / Non Apartment

Building :A (BUILDING)

Floor Name	Total Built Up Area (Sq.mt.)	Deductions (Area in Sq.mt.) Lift	Proposed FAR Area (Sq.mt.) Resi.	Total FAR Area (Sq.mt.)	Total Consumed Additional FAR Area (Sq.mt.)	Tnmt (No.)
Ground Floor	182.60	0.00	182.60	182.60	182.60	01
First Floor	182.60	4.37	178.23	178.23	178.23	01
Second Floor	182.60	4.37	178.23	178.23	178.23	01
Third Floor	182.60	4.37	178.23	178.23	178.23	01
Fourth Floor	182.60	4.37	178.23	178.23	178.23	01
Terrace Floor	0.00	0.00	0.00	0.00	0.00	00
Total :	913.00	17.48	895.52	895.52	895.52	05
Total Number of Same Buildings	1					
Total :	913.00	17.48	895.52	895.52	895.52	05

SCHEDULE OF DOOR:

BUILDING NAME	NAME	LENGTH	HEIGHT	NOS
A (BUILDING)	D1	0.75	2.10	20
A (BUILDING)	D	0.90	2.10	80

SCHEDULE OF WINDOW/VENTILATION:

BUILDING NAME	NAME	LENGTH	HEIGHT	NOS
A (BUILDING)	V	0.90	0.60	20
A (BUILDING)	W	1.20	1.20	80

UnitBUA Table for Building :A (BUILDING)

FLOOR	Name	UnitBUA Type	UnitBUA Area	Carpet Area	No. of Rooms	No. of Tenement
GROUND FLOOR PLAN	SPLIT A	FLAT	169.93	169.65	21	1
FIRST FLOOR PLAN	SPLIT B	FLAT	169.93	169.65	21	1
SECOND FLOOR PLAN	SPLIT C	FLAT	169.93	169.65	21	1
THIRD FLOOR PLAN	SPLIT D	FLAT	169.93	169.65	21	1
FOURTH FLOOR PLAN	SPLIT E	FLAT	169.93	169.65	21	1
Total:	-	-	849.65	848.25	105	5

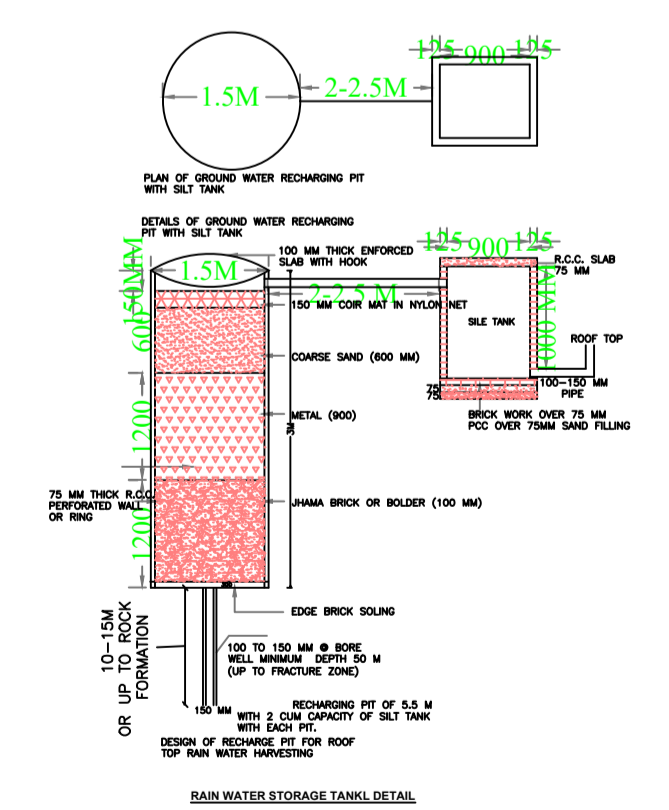
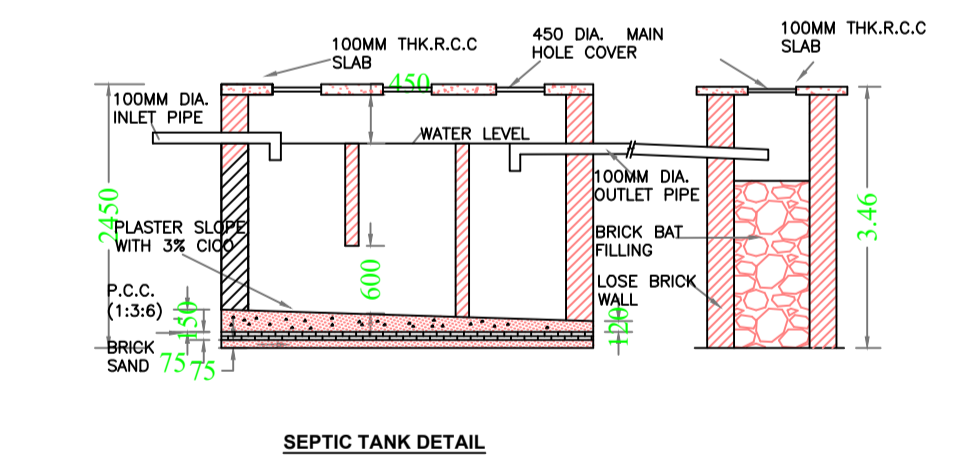
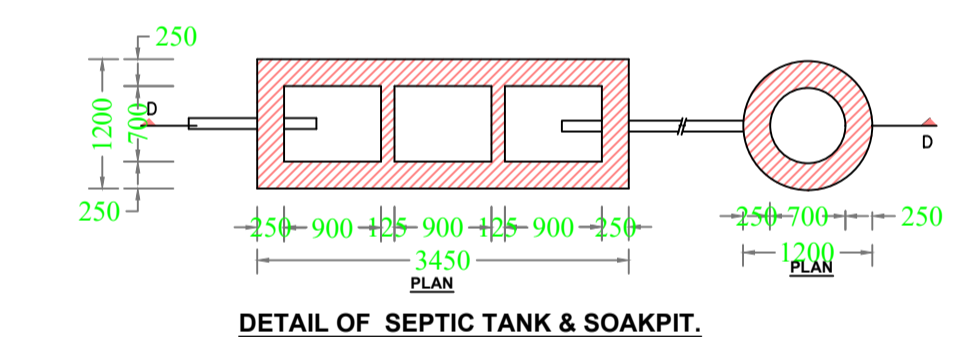
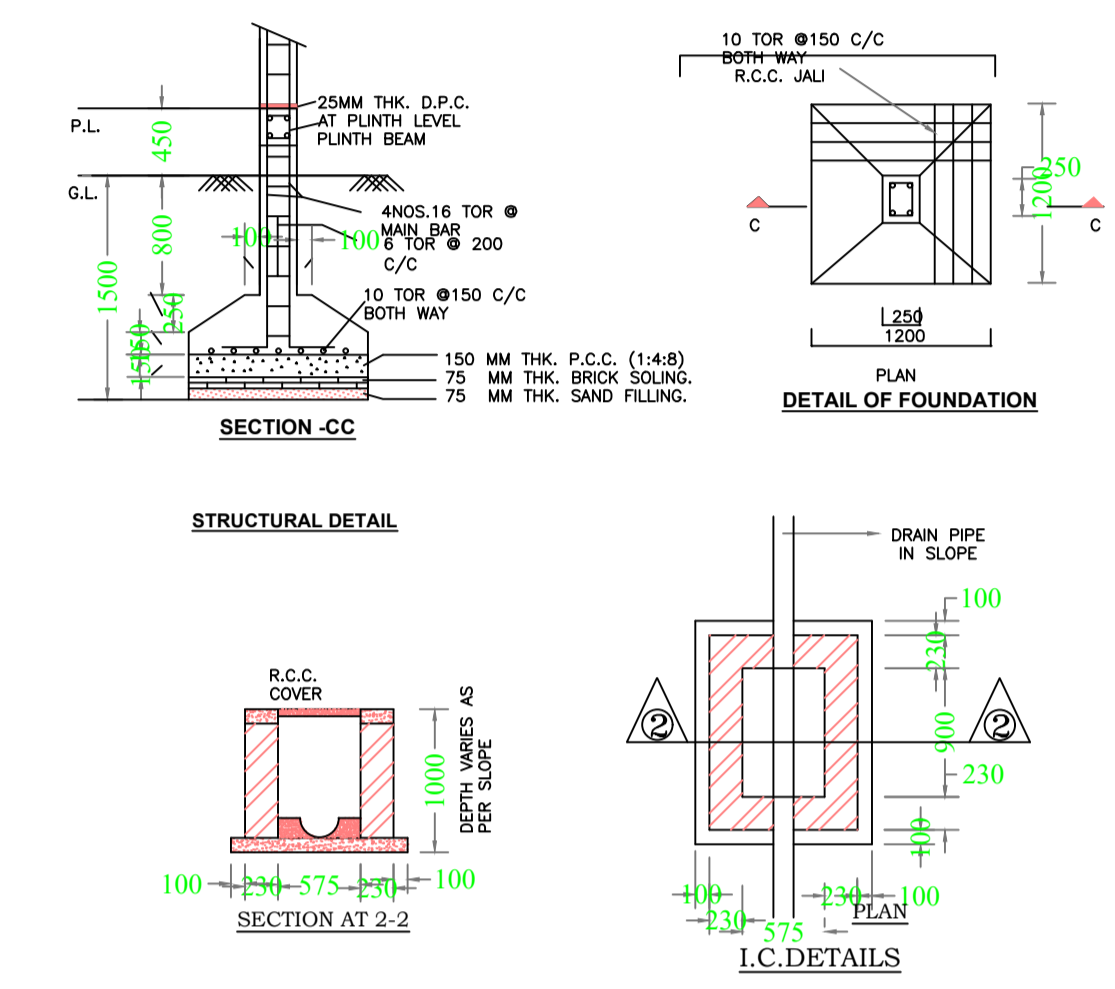
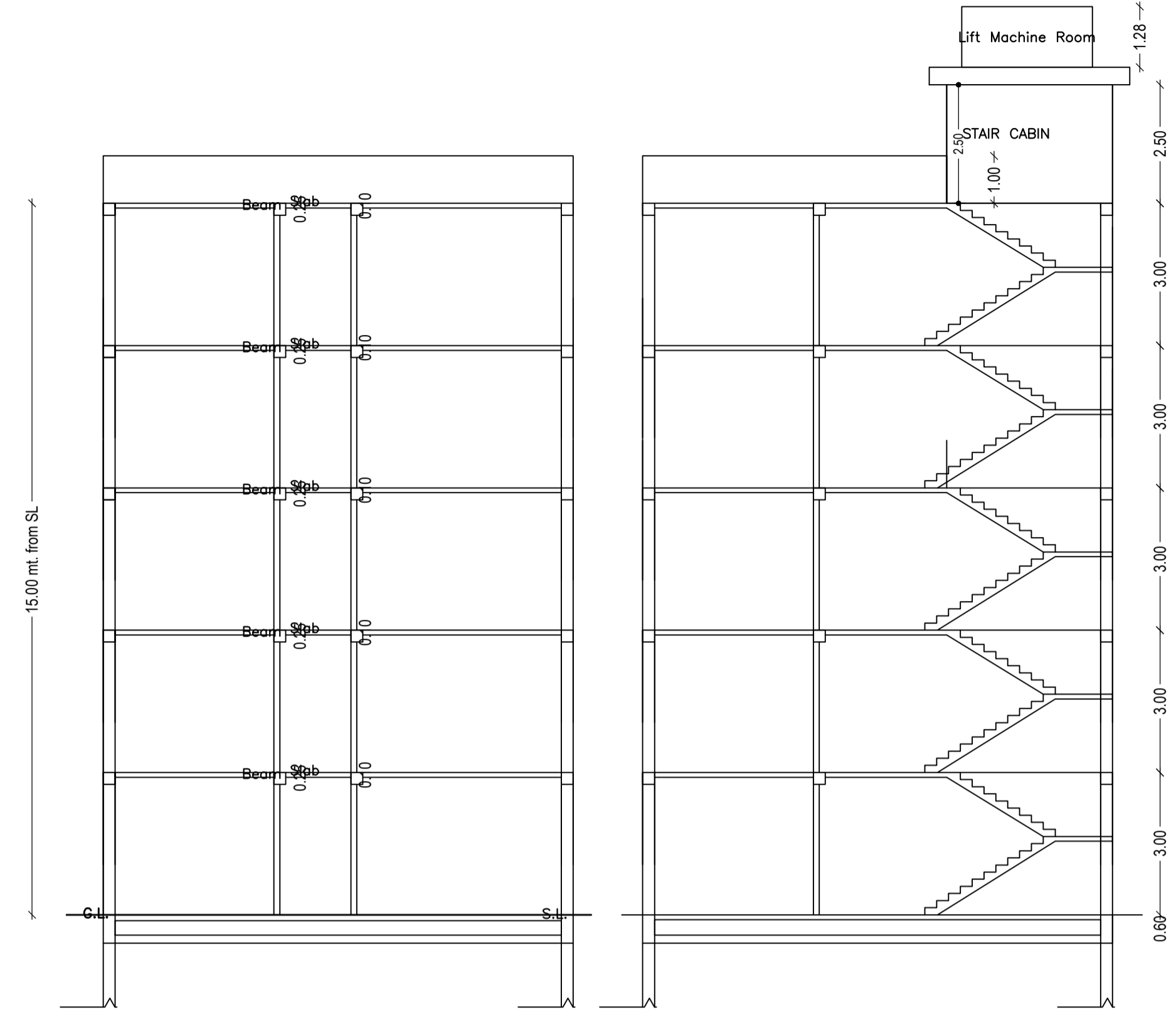

LTP NAME AND SIGNATURE	STRUCTURAL ENG'S NAME AND SIGNATURE	BUILDER NAME AND SIGNATURE	DIGITAL SIGNATURE
RANJIT KUMAR MNNP/ENG/0001/2016			