

Proposal Basic Information

Proposal File No.	MNNP/BP/0063/W17/2021
Owner Name	SARITA DEVI
Khata No	95
Plot No	1679
Village Name	Abadganj
Use	Residential
SubUse	Bungalow/ Dwelling / Non Apartment

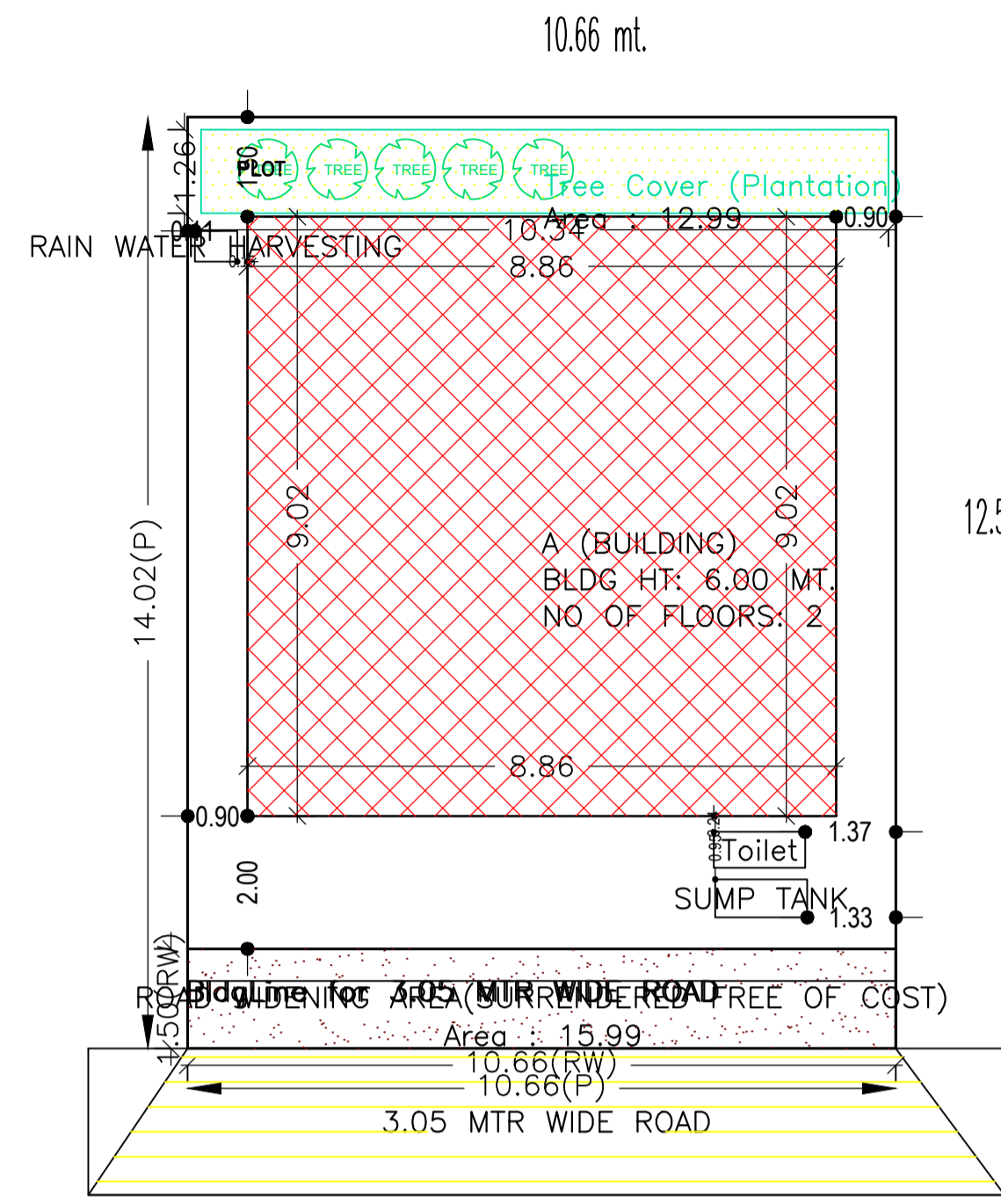

site plan

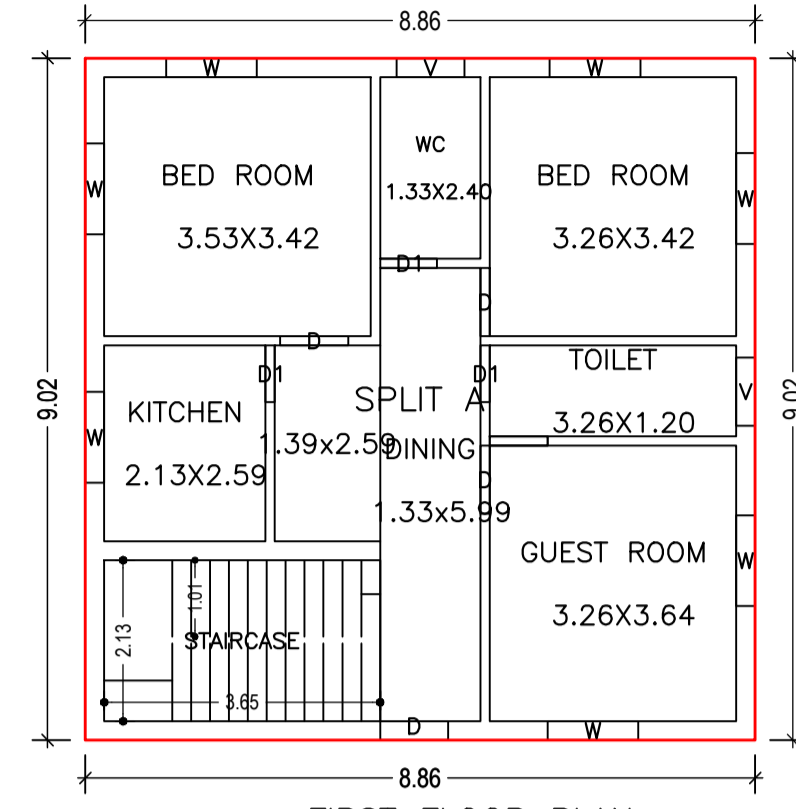

FIRST FLOOR PLAN (Proposed) (SCALE 1:100)

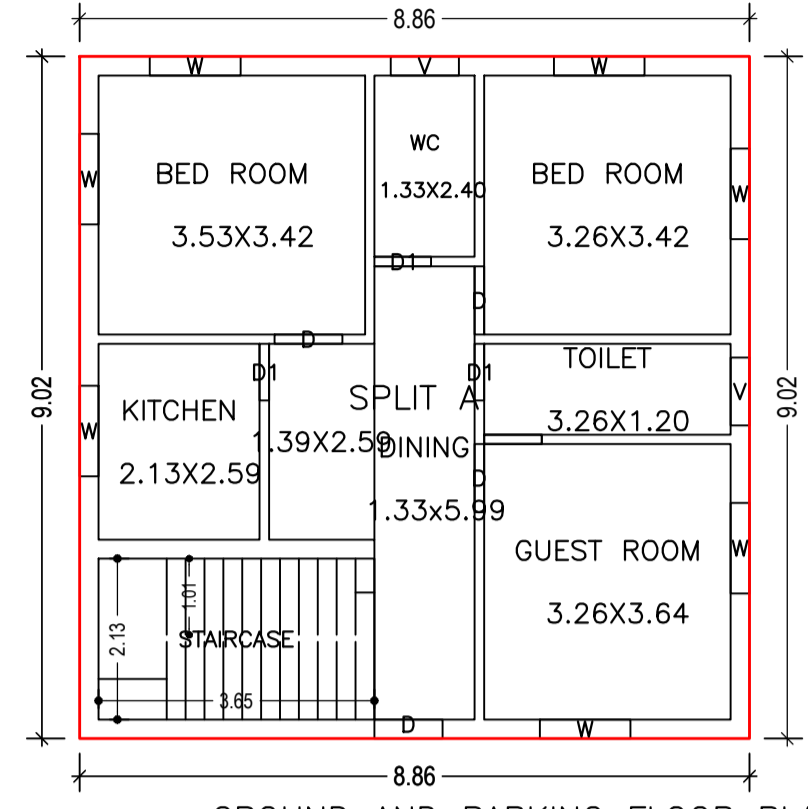

GROUND AND PARKING FLOOR PLAN (Proposed) (SCALE 1:100)

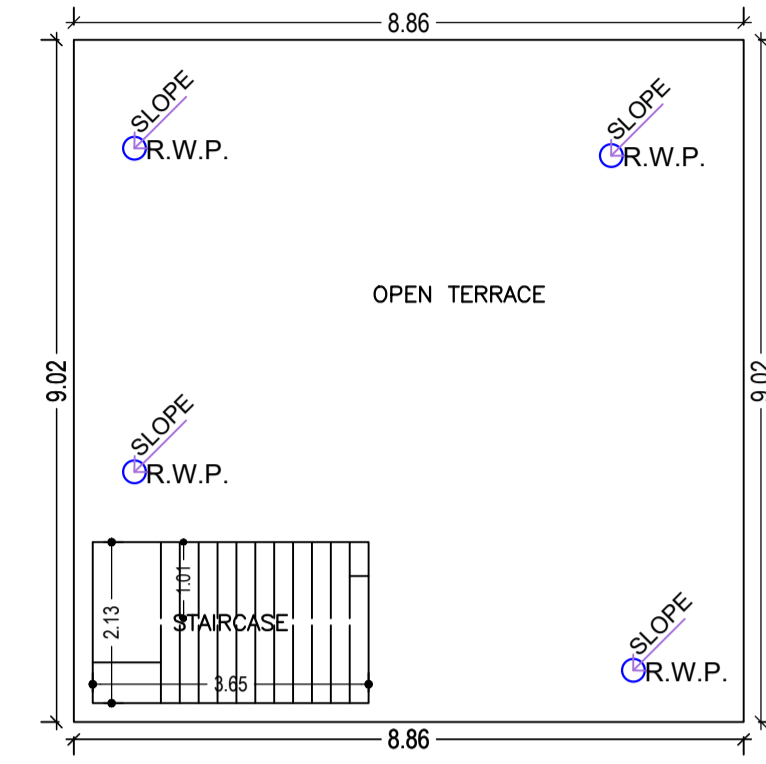

TERRACE FLOOR PLAN (SCALE 1:100)

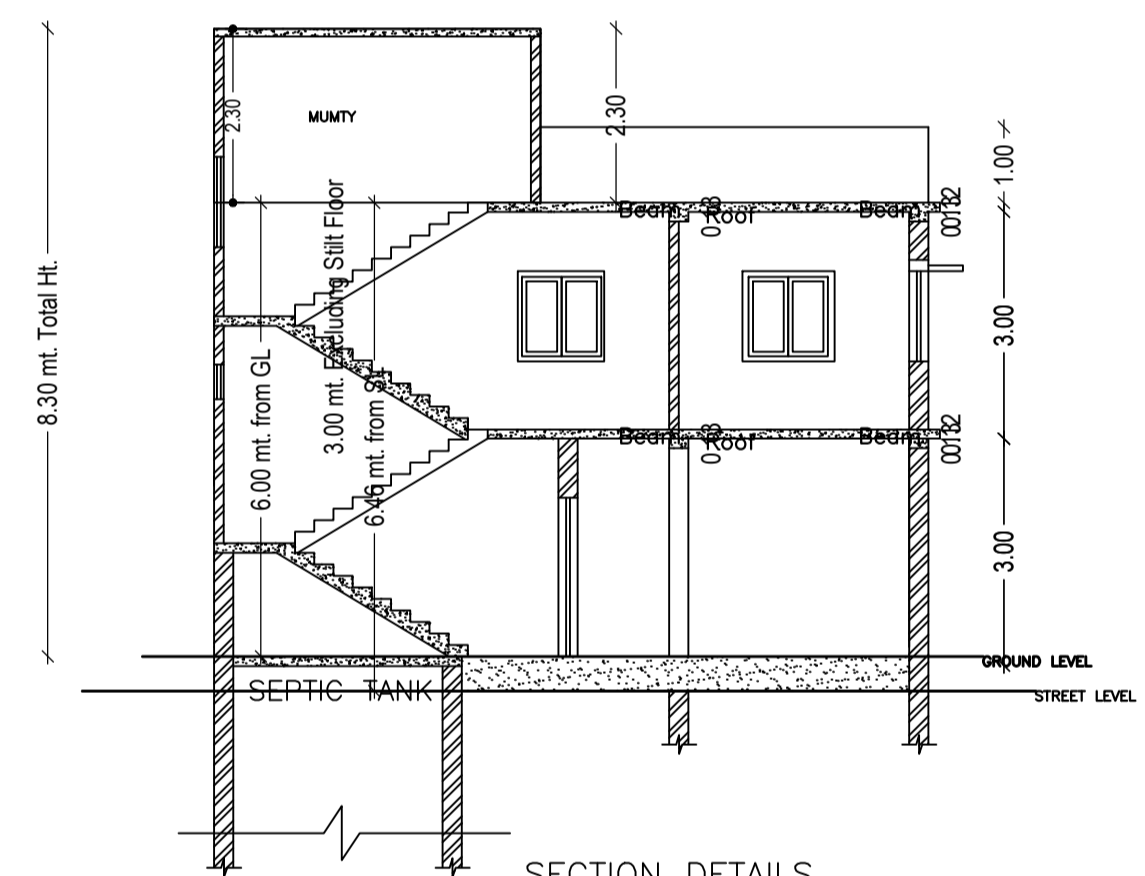

SECTION DETAILS (SCALE 1:100)

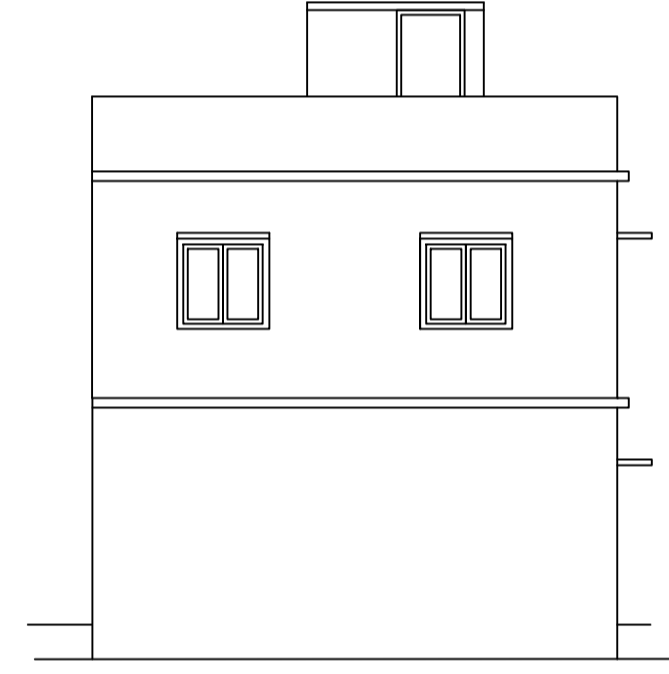

BACK ELEVATION (SCALE 1:100)

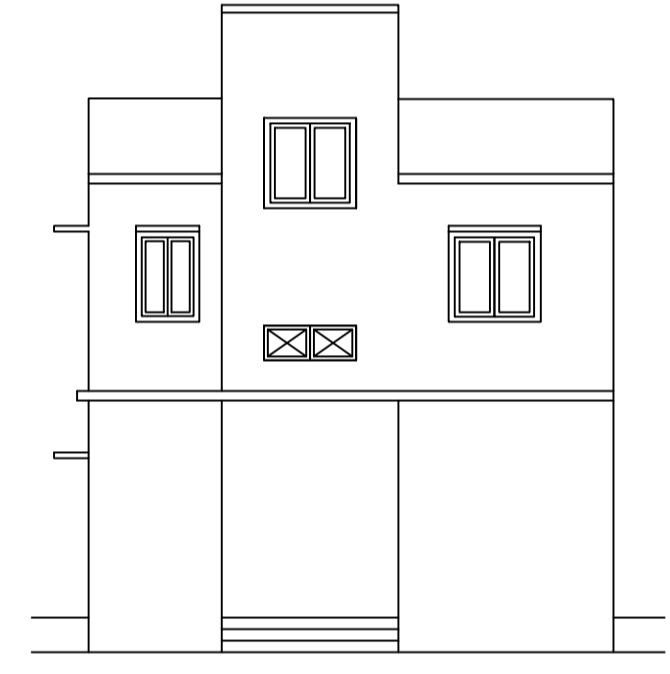

FRONT ELEVATION (SCALE 1:100)

Building :A (BUILDING)

Floor Name	Total Built Up Area (Sq.mt.)	Proposed FAR Area (Sq.mt.) Resi.	Total FAR Area (Sq.mt.)	Total Consumed Additional FAR Area (Sq.mt.)	Tnmt (No.)
Ground And Parking Floor	79.92	79.92	79.92	79.92	01
First Floor	79.92	79.92	79.92	79.92	00
Terrace Floor	0.00	0.00	0.00	0.00	00
Total	159.84	159.84	159.84	159.84	01
Total Number of Same Buildings	1				
Total	159.84	159.84	159.84	159.84	01

SCHEDULE OF DOOR:

BUILDING NAME	NAME	LENGTH	HEIGHT	NOS
A (BUILDING)	D1	0.75	2.10	06
A (BUILDING)	D	0.90	2.10	08

SCHEDULE OF WINDOW/VENTILATION:

BUILDING NAME	NAME	LENGTH	HEIGHT	NOS
A (BUILDING)	V	0.90	0.60	04
A (BUILDING)	W	1.20	1.20	14

UnitBUA Table for Building :A (BUILDING)

FLOOR	Name	UnitBUA Type	UnitBUA Area	Carpet Area	No. of Rooms	No. of Tenement
FIRST FLOOR PLAN	SPLIT A	FLAT	0.00	0.00	7	0
GROUND AND PARKING FLOOR PLAN	SPLIT A	FLAT	141.27	141.08	7	1
Total	-	-	141.27	141.08	14	1

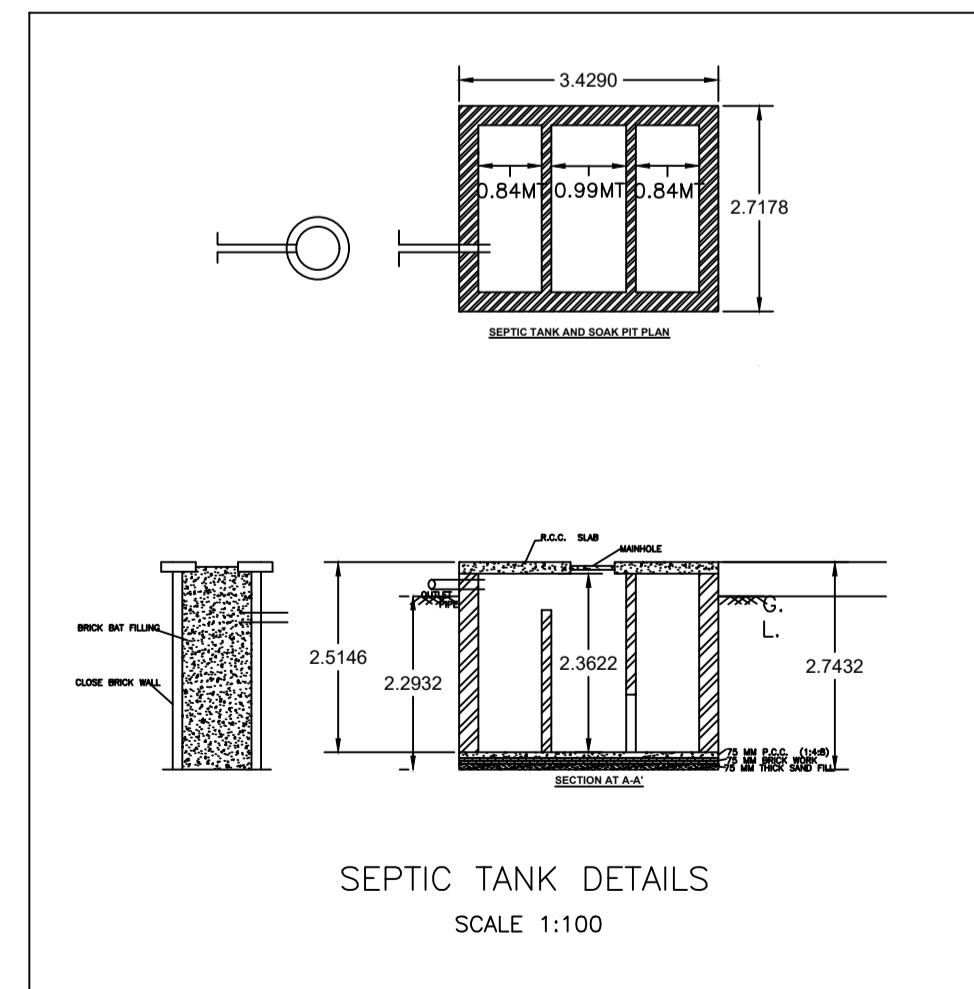

SEPTIC TANK DETAILS (SCALE 1:100)

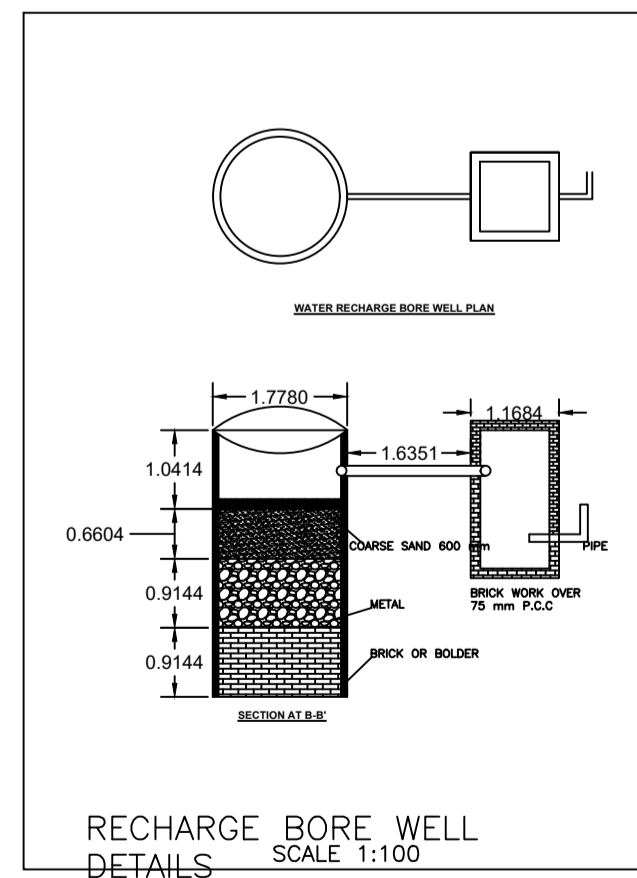

RECHARGE BORE WELL DETAILS (SCALE 1:100)

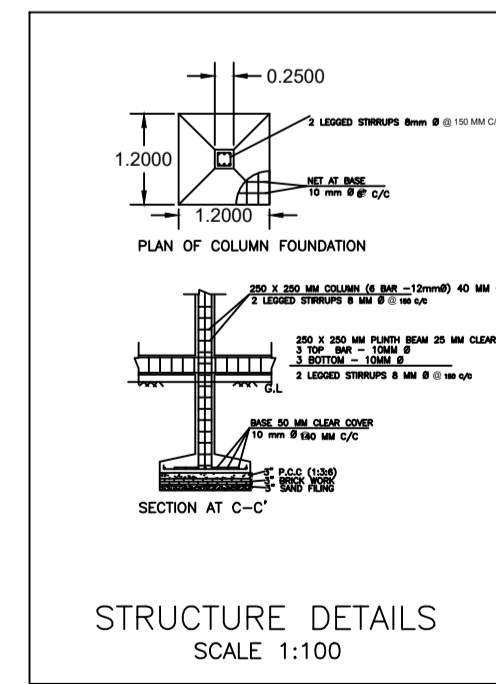

STRUCTURE DETAILS (SCALE 1:100)

AREA STATEMENT	VERSION NO.: 1.0.61	SQ.MT.
MEDININAGAR MUNICIPAL CORPORATION	VERSION DATE: 16/10/2020	
PROJECT DETAIL:		
Region: JHARKHAND URBAN LOCAL BODIES	Plot Use: Residential	
District: PALAMU	Plot SubUse: Bungalow/ Dwelling / Non Apartment	
Authority: MEDININAGAR MUNICIPAL CORPORATION	PlotNearbyReligiousStructure: NA	
Inward No: MNNP/BP/0063/W17/2021	Plot/SubPlot No: 1679	
Application Type: General Proposal	North: -	
Project Type: Building Permission	South: -	
Nature of Development: New	East: -	
Location of Development Area: Old Area	West: -	
AREA DETAILS:		
AREA OF PLOT (Minimum)	(A)	149.45
Deduction for NetPlot Area		
Surrender Free of Cost		15.99
Total		15.99
NET AREA OF PLOT(Gross Plot Area - Deduction from Gross Plot area)	(A-Deductions)	133.46
Deduction for Balance Plot Area(from Gross Plot Area)		
Surrender Free of Cost		15.99
Common Plot		12.99
Total		28.98
BALANCE AREA OF PLOT(Net Plot Area - Recreational/Amenity space)	(A-Deductions)	120.47
PLOT AREA FOR COVERAGE(Net Plot Area)	(A-Deductions)	133.46
Plot Area for FAR (Net Plot Area + Road/Widening Area)	(A-Deductions)	149.45
COVERAGE CHECK		
Permissible Coverage area ( 70.00 % )		93.42
Proposed Coverage Area ( 59.88 % )		79.92
Total Prop. Coverage Area ( 59.88 % )		79.92
Balance coverage area ( 10.12 % )		13.50
FAR CHECK		
Perm. FAR Area ( 1.20 )		179.34
Total Perm. FAR area		179.34
Residential FAR		159.83
Proposed FAR Area		159.83
Total Proposed FAR Area		159.83
Consumed FAR (Factor)		1.07
Balance FAR Area		19.51
BUILT UP AREA CHECK		
Total Proposed BuiltUp Area		159.84
ARCHITECT (Regd)	PANKAJ KUMAR SINGH	
ENGINEER (Regd)		
SUPERVISOR (Regd)		
OWNER (Regd)	SARITA DEVI	
DEVELOPMENT AUTHORITY	LOCAL BODY	

COLOR INDEX

PLOT BOUNDARY	Black
ABUTTING ROAD	Green
PROPOSED CONSTRUCTION	Red
COMMON PLOT	Yellow
ROAD WIDENING AREA	Blue
EXISTING (To be retained)	Light Blue
EXISTING (To be demolished)	Dark Blue

Buildingwise Floor FAR Details

Floor Name	Building Name A (BUILDING)		Total	
	Proposed Built Up Area (Sq.mt.)	Proposed FAR Area (Sq.mt.)	Total Proposed Built Up Area (Sq.mt.)	Total FAR Area (Sq.mt.)
Ground And Parking Floor	79.92	79.92	79.92	79.92
First Floor	79.92	79.92	79.92	79.92
Terrace Floor	0.00	0.00	0.00	0.00
Total	159.84	159.84	159.84	159.84

Building USE/SUBUSE Details

Building Name	Building Use	Building SubUse	Building Structure
A (BUILDING)	Residential	Bungalow/ Dwelling / Non Apartment	Non-Highrise

FAR & Tenement Details (Table 4c-1)

Building	No. of Same Bldg	Total Built Up Area (Sq.mt.)	Proposed FAR Area (Sq.mt.) Resi.	Total FAR Area (Sq.mt.)	Total Consumed Additional FAR Area (Sq.mt.)	Tnmt (No.)
A (BUILDING)	1	159.84	159.84	159.84	159.84	01
Grand Total :	1	159.84	159.84	159.84	159.84	01

LTP NAME AND SIGNATURE	STRUCTURAL ENG'S NAME AND SIGNATURE	BUILDER NAME AND SIGNATURE	DIGITAL SIGNATURE
PANKAJ KUMAR SINGH MNNP/ENG/0006/2019			