

SITE PLAN

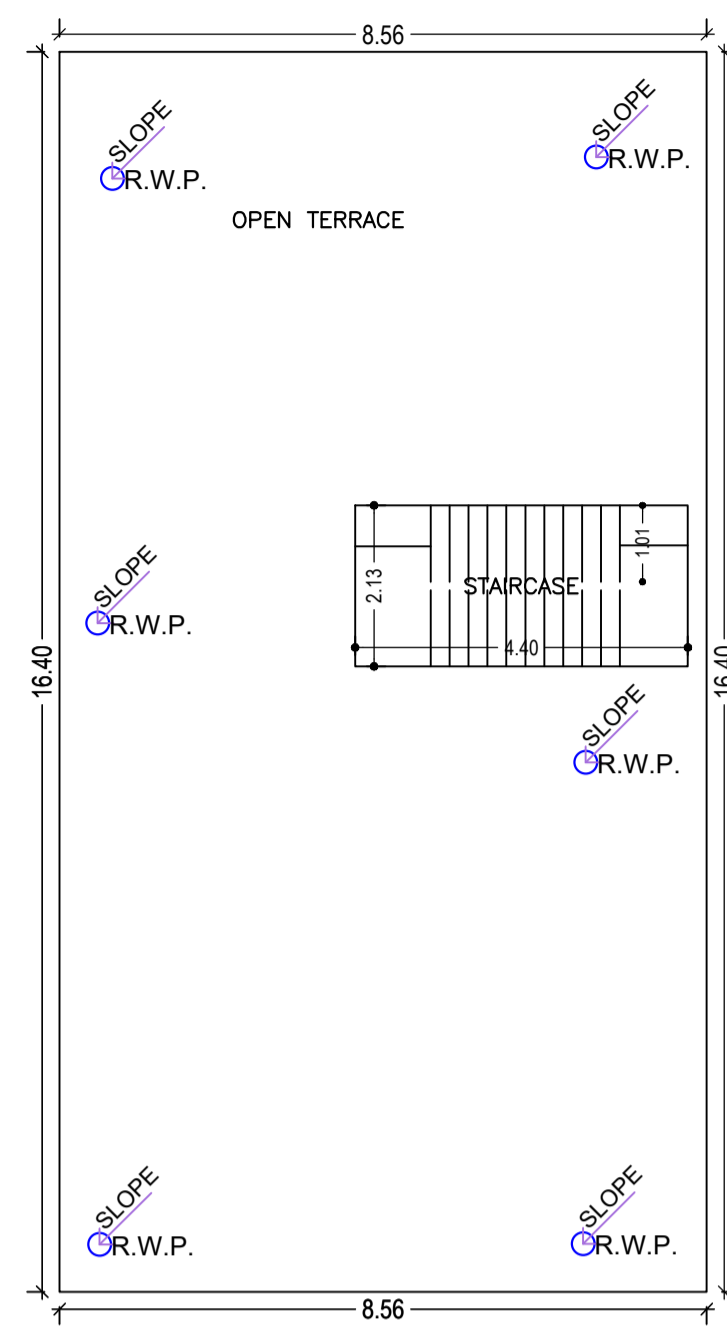

TERRACE FLOOR PLAN (SCALE 1:100)

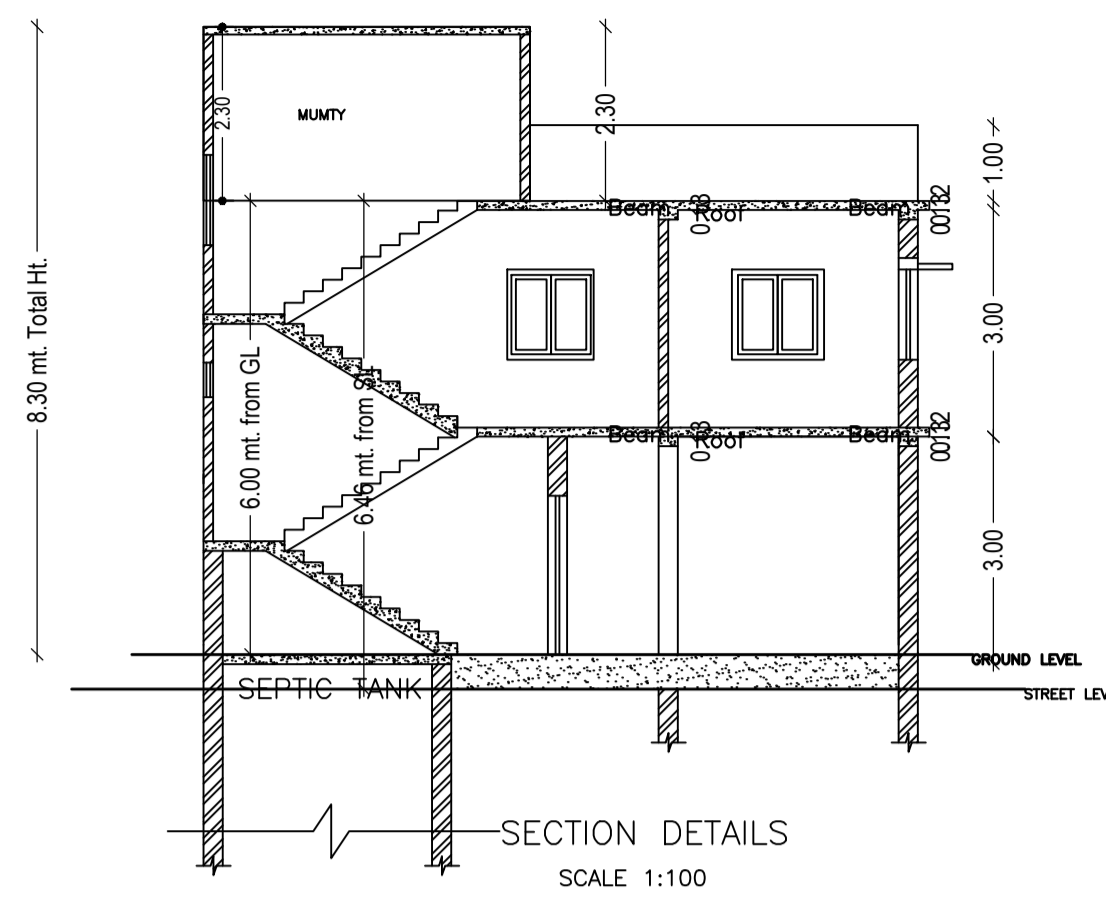

SECTION DETAILS (SCALE 1:100)

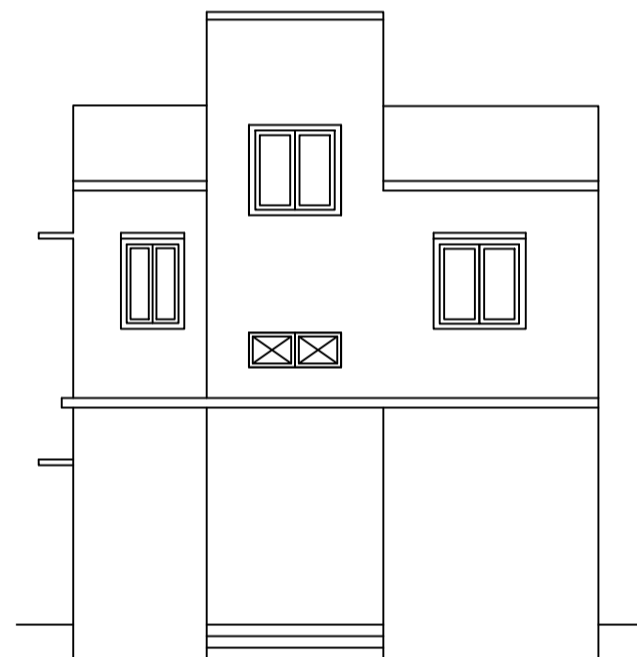

FRONT ELEVATION (SCALE 1:100)

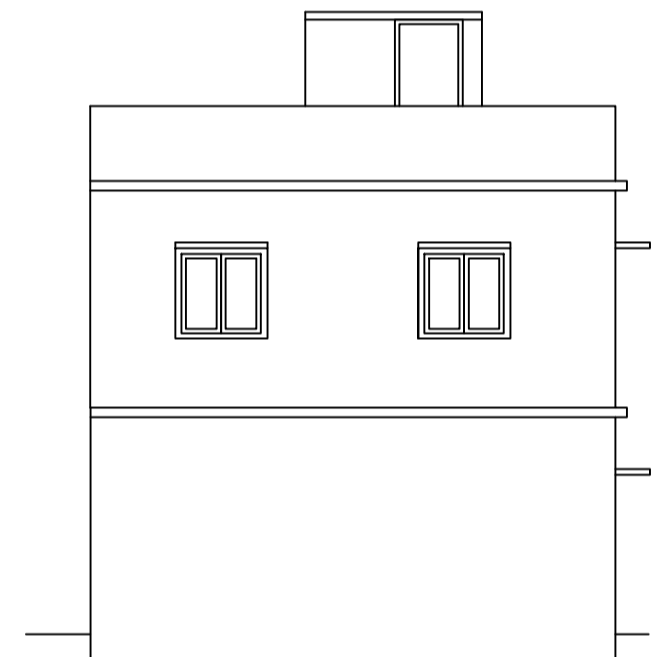

BACK ELEVATION (SCALE 1:100)

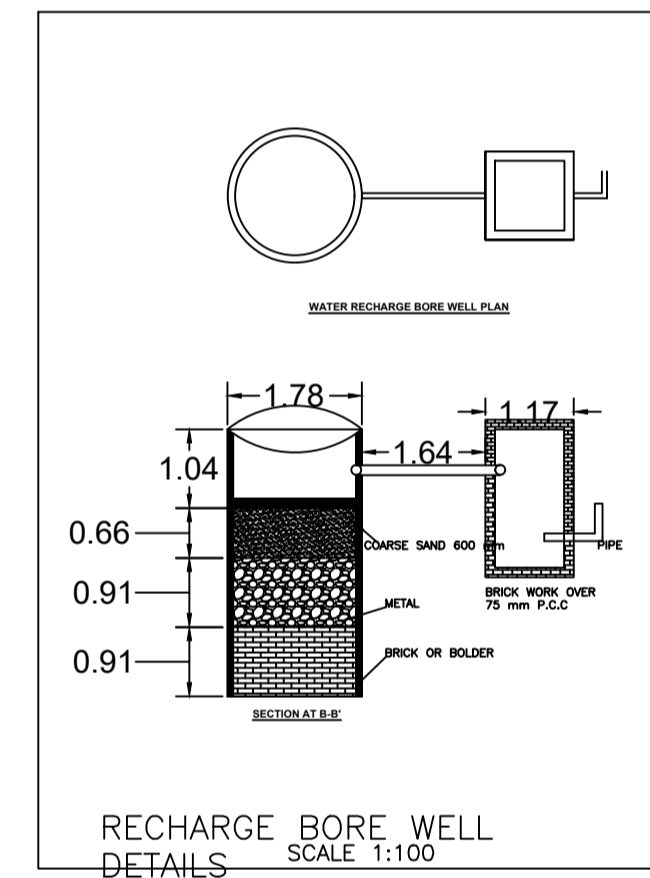

RECHARGE BORE WELL DETAILS (SCALE 1:100)

FAR & Tenement Details (Table 4c-1)

Building	No. of Same Bldg	Total Built Up Area (Sq.mt.)	Deductions (Area in Sq.mt.)	Proposed FAR Area (Sq.mt.)	Total FAR Area (Sq.mt.)	Total Consumed Additional FAR Area (Sq.mt.)	Tnmt (No.)
A (BUILDING)	1	281.83	70.79	211.04	211.04	211.04	01
Grand Total :	1	281.83	70.79	211.04	211.04	211.04	01

Proposal Basic Information

Proposal File No.	MNNP/BP/0170/W04/2021
Owner Name	ANU DEVI
Khata No	203
Plot No	345
Village Name	Baralota Rodma
Use	Residential
SubUse	Bungalow/ Dwelling / Non Apartment

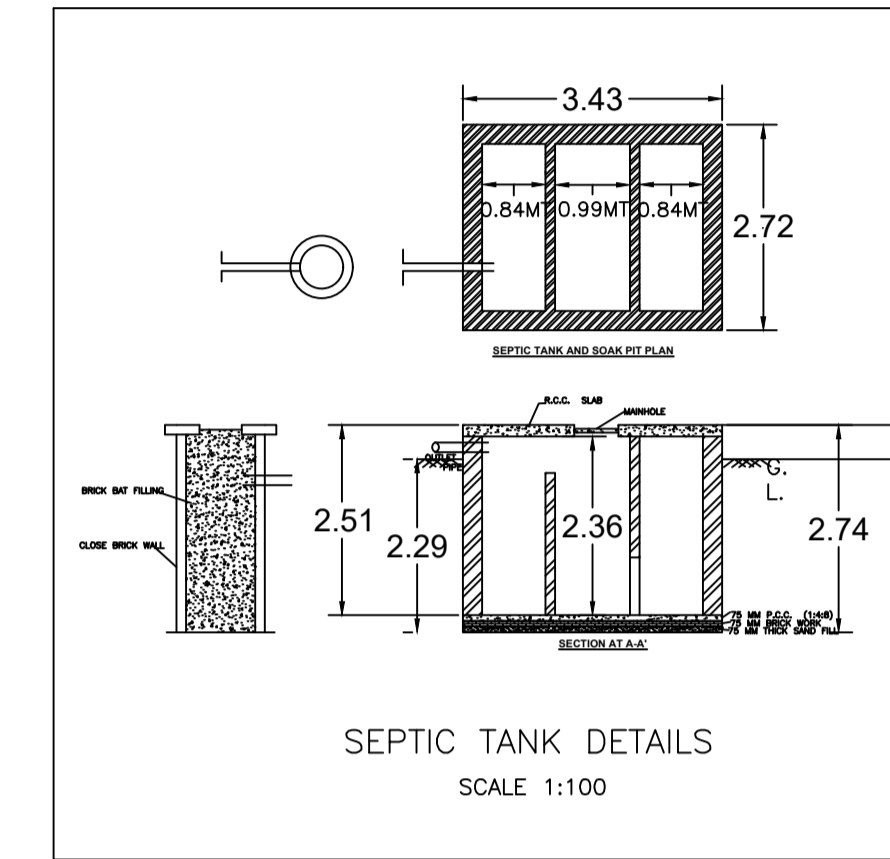

SEPTIC TANK DETAILS (SCALE 1:100)

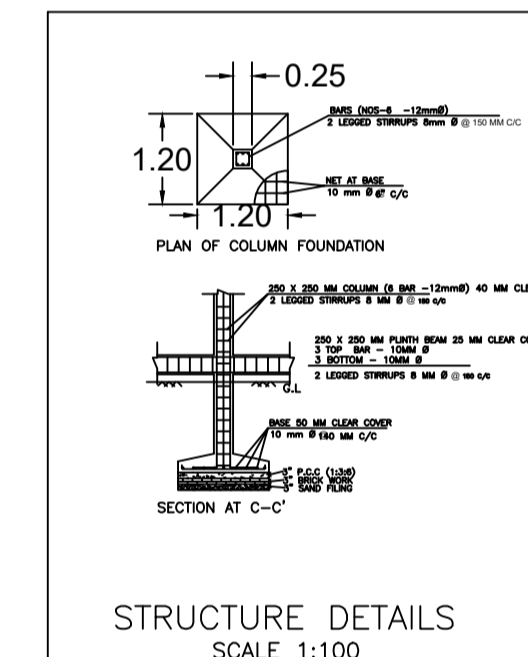

STRUCTURE DETAILS (SCALE 1:100)

AREA STATEMENT		VERSION NO. : 1.0.62
MEDININAGAR MUNICIPAL CORPORATION		VERSION DATE: 16/10/2020
PROJECT DETAIL:		
Region: JHARKHAND URBAN LOCAL BODIES	Plot Use: Residential	
District: PALAMU	Plot SubUse: Bungalow/ Dwelling / Non Apartment	
Authority: MEDININAGAR MUNICIPAL CORPORATION	PlotNearbyReligiousStructure: NA	
Inward No: MNNP/BP/0170/W04/2021	Plot/SubPlot No: 345	
Application Type: General Proposal	North: -	
Project Type: Building Permission	South: -	
Nature of Development: New	East: -	
Location of Development Area: Old Area	West: -	
AREA DETAILS:		
AREA OF PLOT (Minimum)	(A)	242.50
Deduction for NetPlot Area		
Surrender Free of Cost		11.81
Total		11.81
NET AREA OF PLOT(Gross Plot Area - Deduction from Gross Plot area)	(A-Deductions)	230.69
Deduction for Balance Plot Area(from Gross Plot Area)		
Surrender Free of Cost		11.81
Common Plot		21.51
Total		33.32
BALANCE AREA OF PLOT(Net Plot Area - Recreational/Amenity space)	(A-Deductions)	209.18
PLOT AREA FOR COVERAGE(Net Plot Area)	(A-Deductions)	230.69
Plot Area for FAR (Net Plot Area + Road/Widening Area)	(A-Deductions)	242.50
COVERAGE CHECK:		
Permissible Coverage area (70.00 %)		161.48
Proposed Coverage Area (60.85 %)		140.38
Total Prop. Coverage Area (60.85 %)		140.38
Balance coverage area (9.15 %)		21.10
FAR CHECK:		
Perm. FAR Area (1.20)		291.00
Total Perm. FAR area		291.00
Residential FAR		211.05
Proposed FAR Area		211.05
Total Proposed FAR Area		211.05
Consumed FAR (Factor)		0.87
Balance FAR Area		79.95
BUILT UP AREA CHECK:		
Total Proposed BuiltUp Area		281.83
ARCHITECT (Regd)	CHANDRA SHEKHAR THAKUR	
ENGINEER (Regd)		
SUPERVISOR (Regd)		
OWNER (Regd)	ANU DEVI	
DEVELOPMENT AUTHORITY		LOCAL BODY

COLOR INDEX	
PLOT BOUNDARY	Black
ABUTTING ROAD	Green
PROPOSED CONSTRUCTION	Red
COMMON PLOT	Yellow
ROAD WIDENING AREA	Blue
EXISTING (To be retained)	Grey
EXISTING (To be demolished)	White

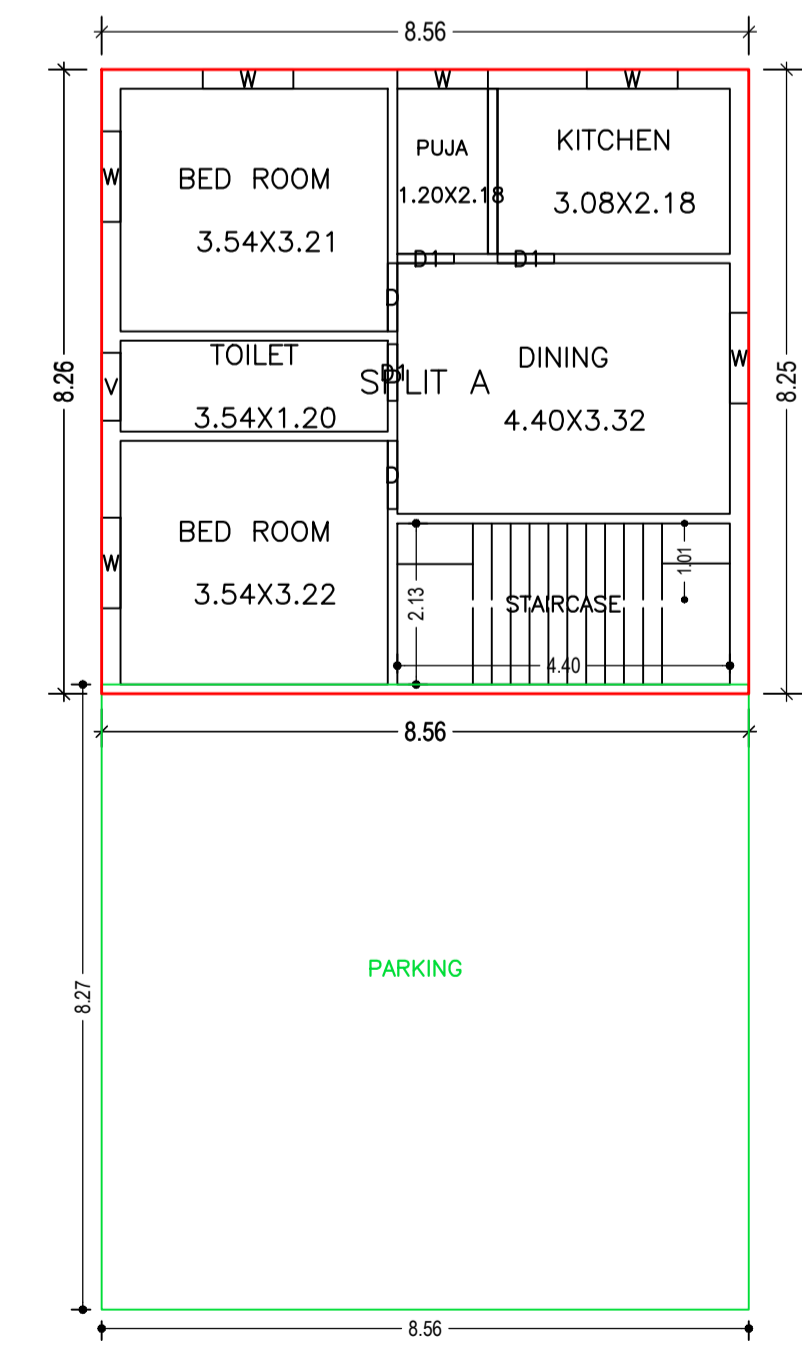

GROUND FLOOR PLAN (Proposed) (SCALE 1:100)

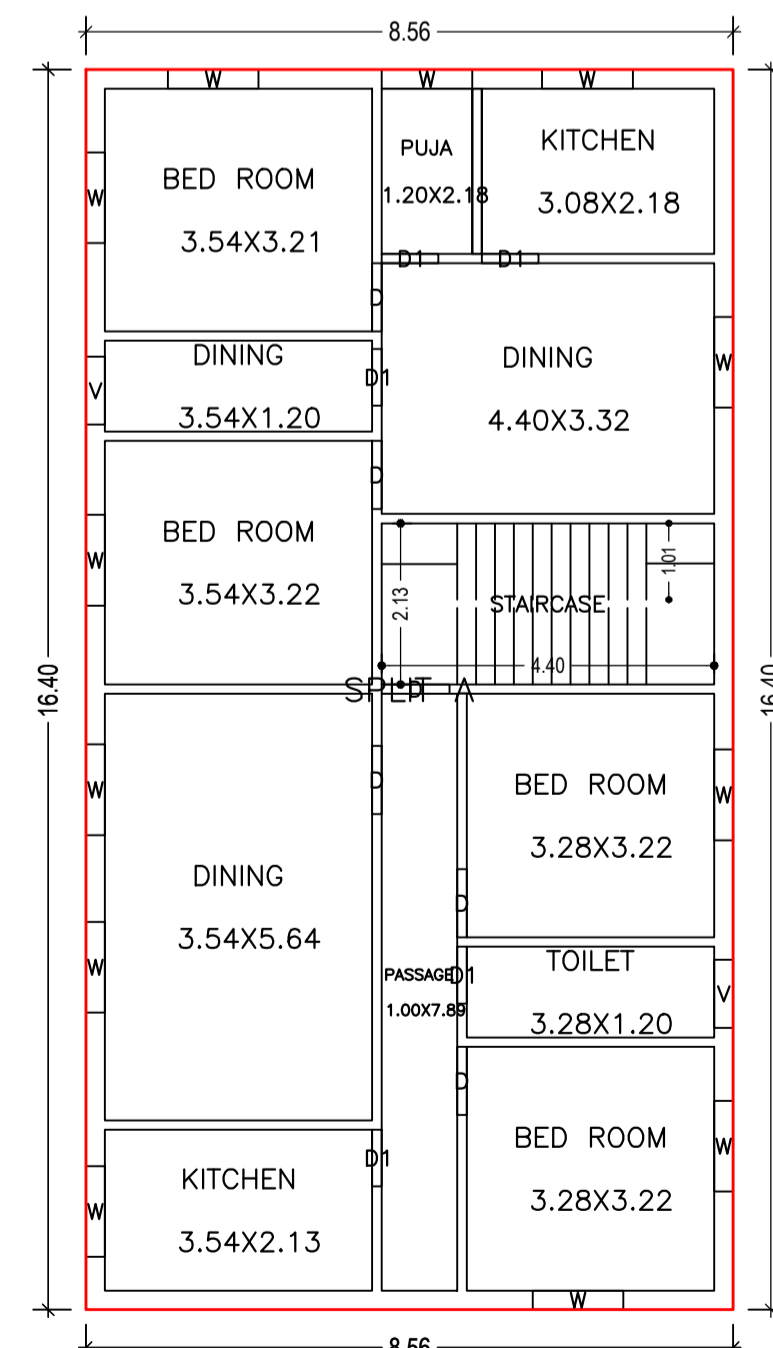

FIRST FLOOR PLAN (Proposed) (SCALE 1:100)

Building :A (BUILDING)

Floor Name	Total Built Up Area (Sq.mt.)	Deductions (Area in Sq.mt.)	Proposed FAR Area (Sq.mt.)	Total FAR Area (Sq.mt.)	Total Consumed Additional FAR Area (Sq.mt.)	Tnmt (No.)
Ground Floor	141.45	70.79	70.66	70.66	70.66	01
First Floor	140.38	0.00	140.38	140.38	140.38	00
Terrace Floor	0.00	0.00	0.00	0.00	0.00	00
Total :	281.83	70.79	211.04	211.04	211.04	01
Total Number of Same Buildings	1					
Total :	281.83	70.79	211.04	211.04	211.04	01

UnitBUA Table for Building :A (BUILDING)

FLOOR	Name	UnitBUA Type	UnitBUA Area	Carpet Area	No. of Rooms	No. of Tenement
GROUND FLOOR PLAN	SPLIT A	FLAT	190.66	190.11	6	1
FIRST FLOOR PLAN	SPLIT A	FLAT	0.00	0.00	12	0
Total:	-	-	190.66	190.11	18	1

SCHEDULE OF DOOR:

BUILDING NAME	NAME	LENGTH	HEIGHT	NOS
A (BUILDING)	D1	0.75	2.10	08
A (BUILDING)	D	0.90	2.10	08

SCHEDULE OF WINDOW/VENTILATION:

BUILDING NAME	NAME	LENGTH	HEIGHT	NOS
A (BUILDING)	V	0.90	0.60	03
A (BUILDING)	W	1.20	1.20	18

LTP NAME AND SIGNATURE	STRUCTURAL ENG'S NAME AND SIGNATURE	BUILDER NAME AND SIGNATURE	DIGITAL SIGNATURE
CHANDRA SHEKHAR THAKUR MNNP/ENG/0004/2020			