

Proposal Basic Information	
Proposal File No.	MNNP/BP/0151/W26/2021
Owner Name	TABASSUM AFSHAN
Khata No	0
Plot No	550
Village Name	Kundh
Use	Residential
SubUse	Bungalow/ Dwelling / Non Apartment

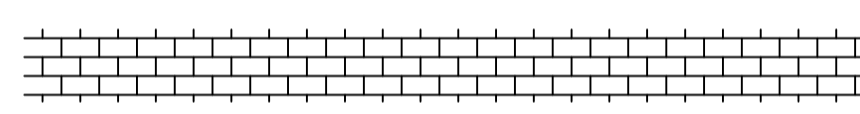
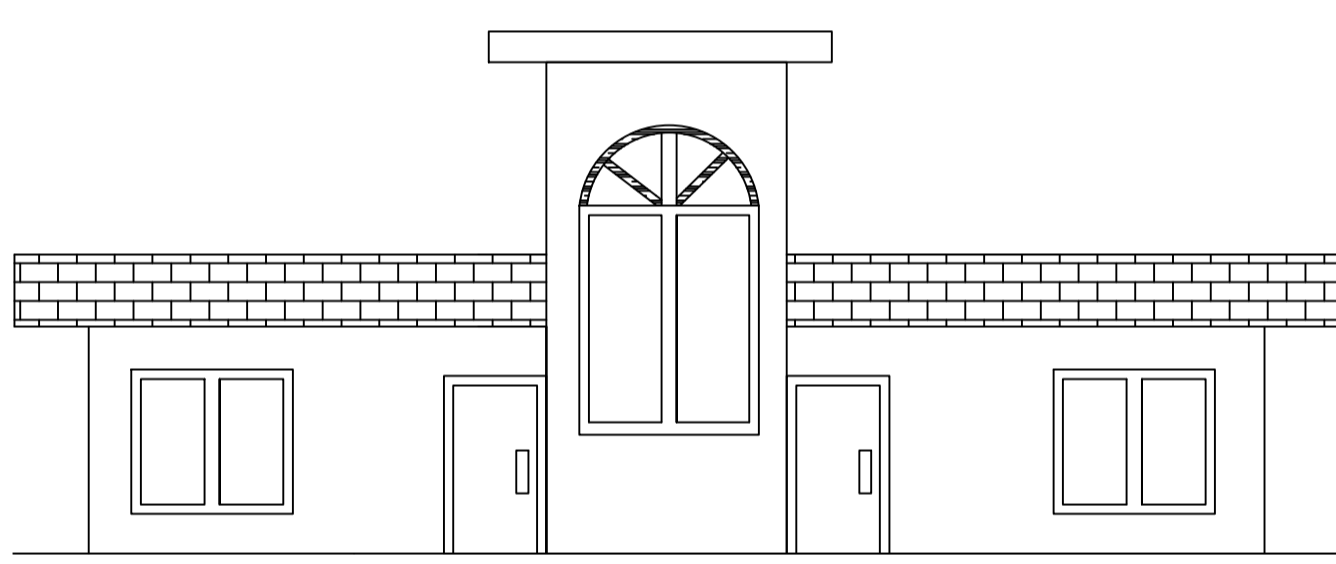
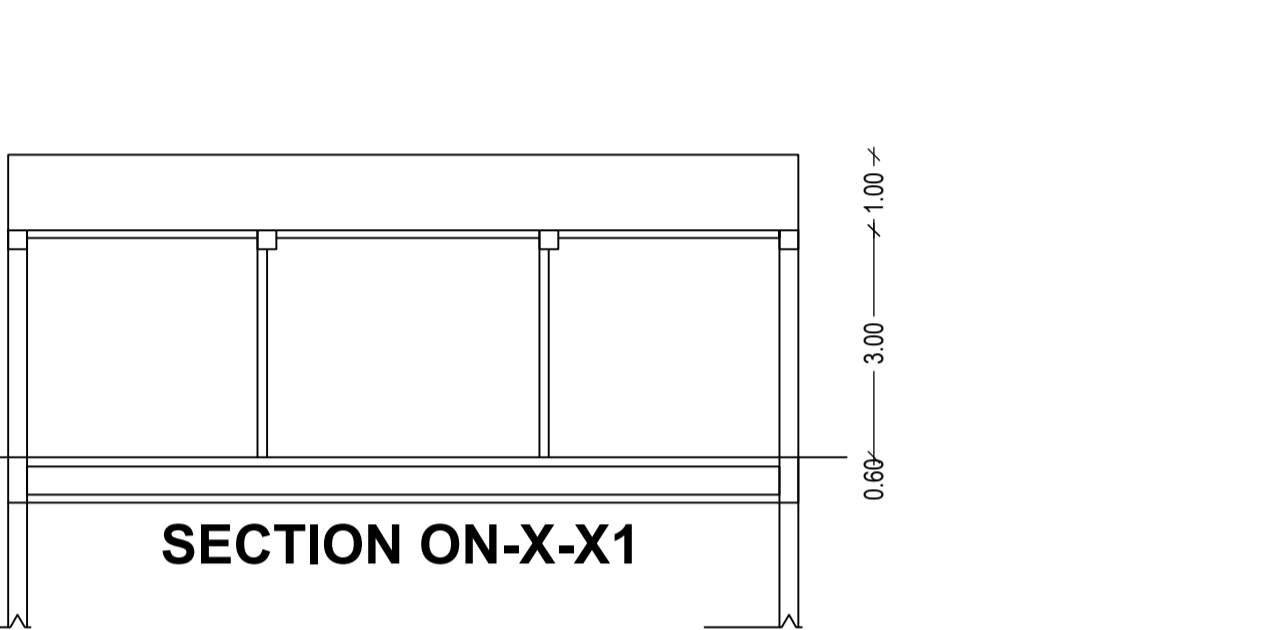
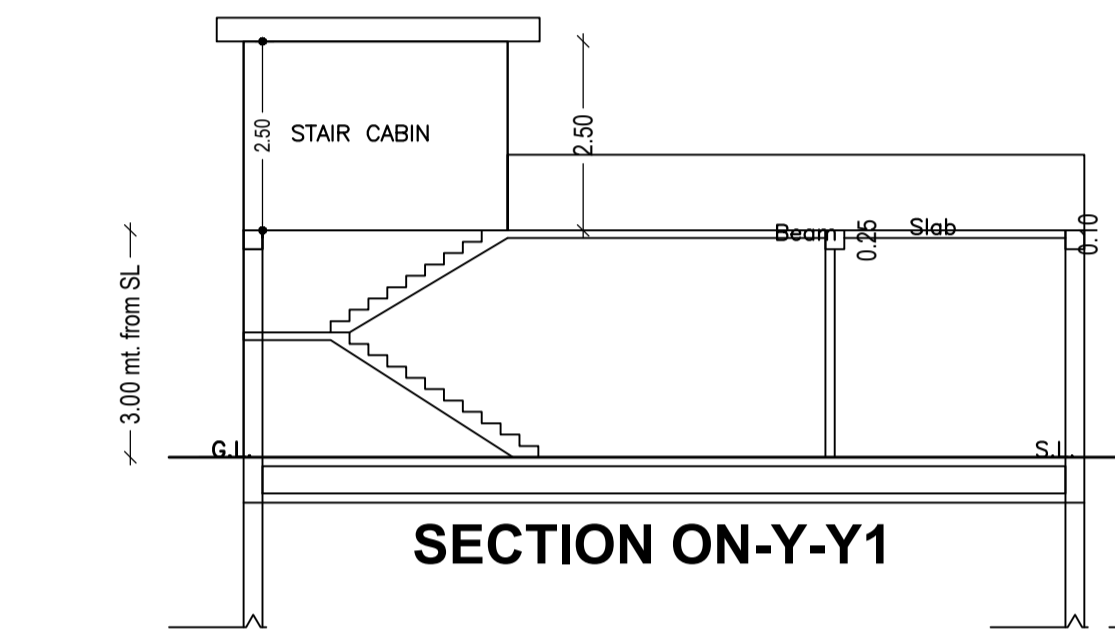
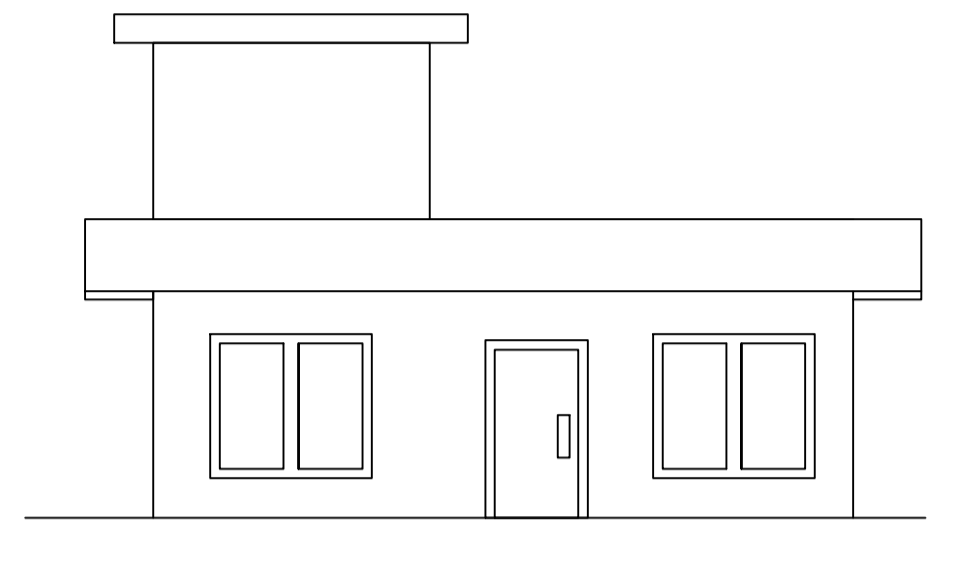
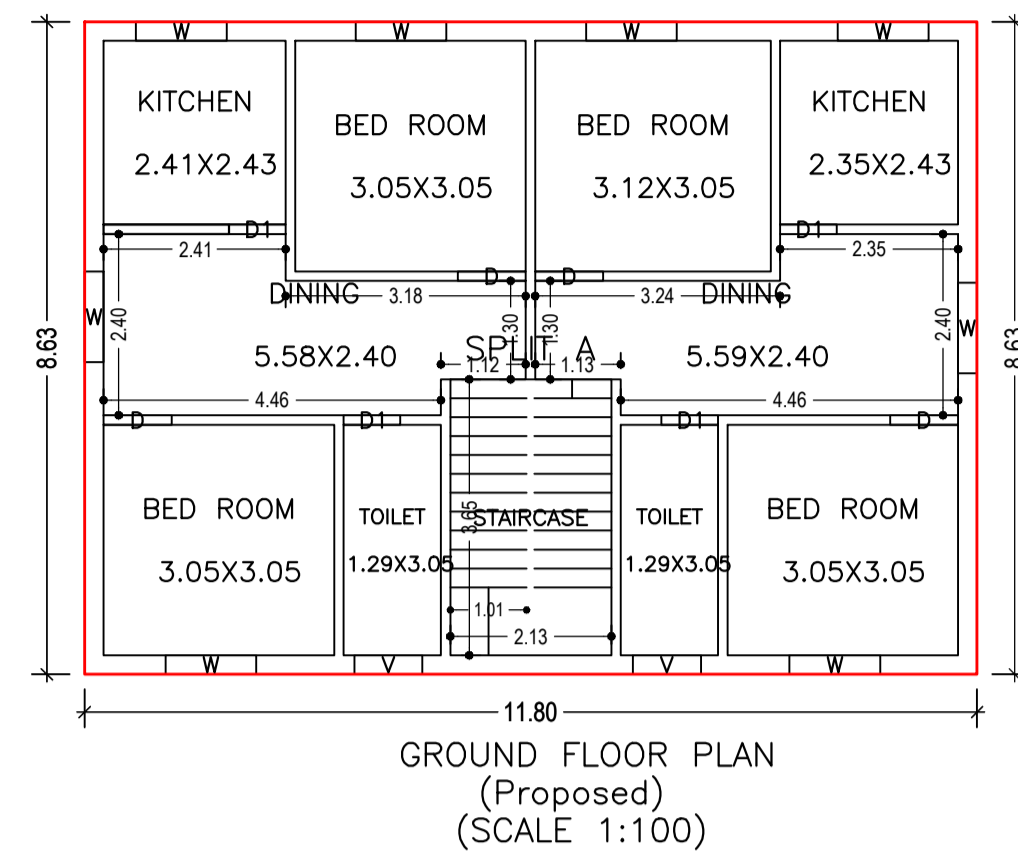
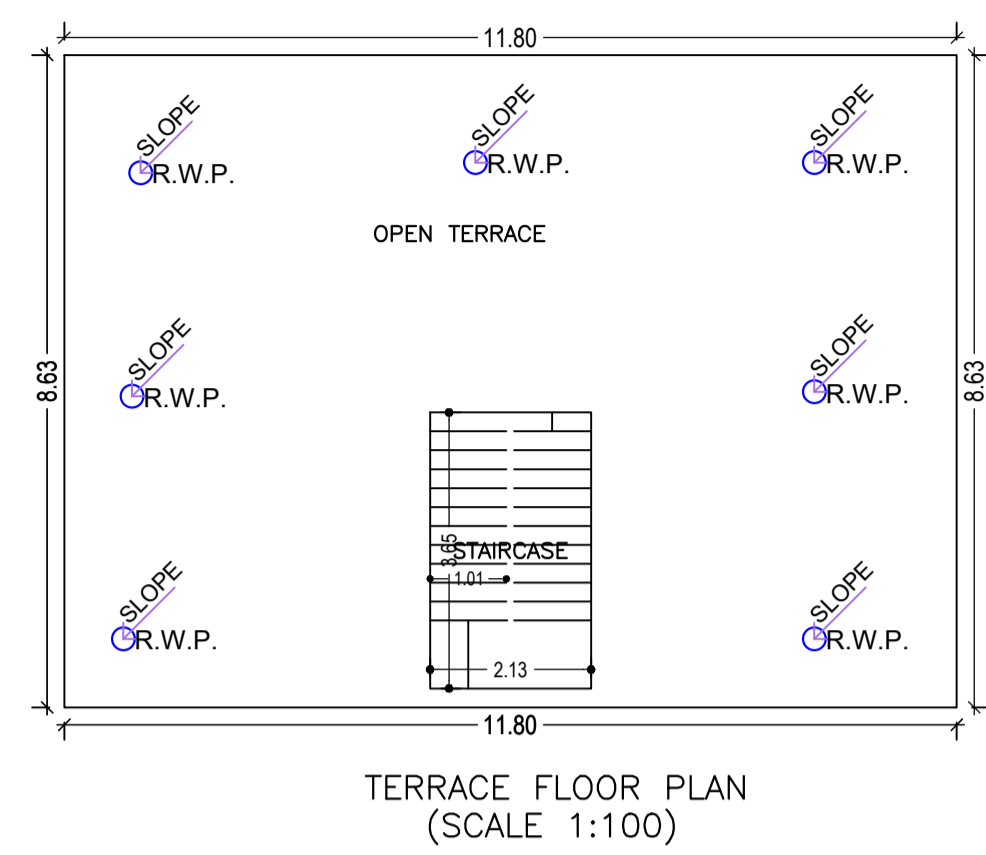
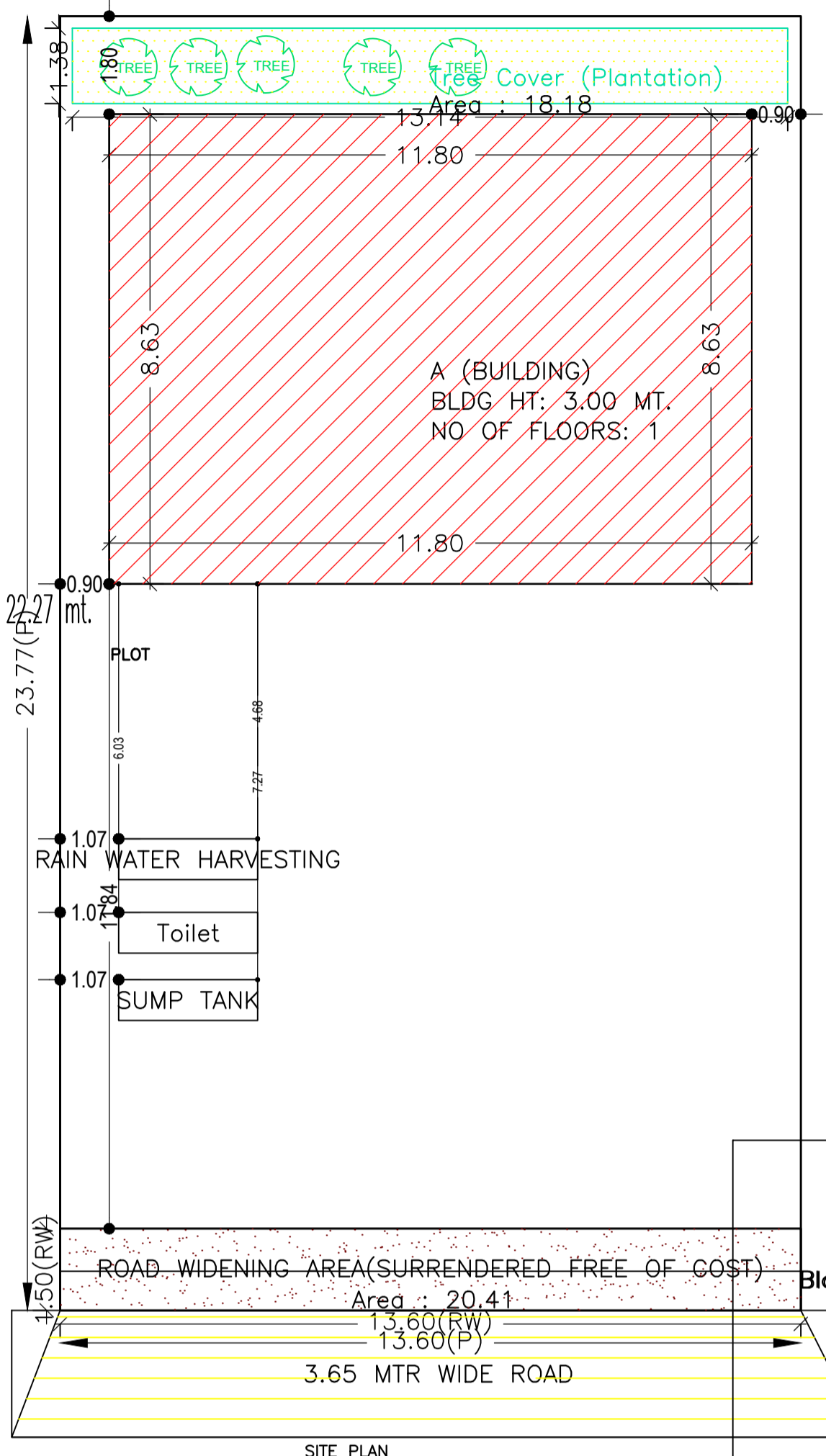

AREA STATEMENT		VERSION NO.:	1.0.61
MEDININAGAR MUNICIPAL CORPORATION		VERSION DATE: 16/10/2020	
PROJECT DETAIL:			
Region: JHARKHAND URBAN LOCAL BODIES	Plot Use: Residential		
District: PALAMU	Plot SubUse: Bungalow/ Dwelling / Non Apartment		
Authority: MEDININAGAR MUNICIPAL CORPORATION	PlotNearbyReligiousStructure: NA		
Inward No: MNNP/BP/0151/W26/2021	Plot/SubPlot No: 550		
Application Type: General Proposal	North: -		
Project Type: Building Permission	South: -		
Nature of Development: New	East: -		
Location of Development Area: Old Area	West: -		
AREA DETAILS:		SQ.MT.	
AREA OF PLOT (Minimum)	(A)	322.90	
Deduction for NetPlot Area			
Surrender Free of Cost		20.41	
Total		20.41	
NET AREA OF PLOT(Gross Plot Area - Deduction from Gross Plot area)	(A-Deductions)	302.49	
Deduction for Balance Plot Area(from Gross Plot Area)			
Surrender Free of Cost		20.41	
Common Plot		18.18	
Total		38.58	
BALANCE AREA OF PLOT(Net Plot Area - Recreational/Amenity space)	(A-Deductions)	284.32	
PLOT AREA FOR COVERAGE(Net Plot Area)	(A-Deductions)	302.49	
Plot Area for FAR (Net Plot Area + Road/Widening Area)	(A-Deductions)	322.90	
COVERAGE CHECK			
Permissible Coverage area (60.00 %)		181.49	
Proposed Coverage Area (33.67 %)		101.85	
Total Prop. Coverage Area (33.67 %)		101.85	
Balance coverage area (26.33 %)		79.64	
FAR CHECK			
Perm. FAR Area (1.50)		484.35	
Total Perm. FAR area		484.35	
Residential FAR		101.85	
Proposed FAR Area		101.85	
Total Proposed FAR Area		101.85	
Consumed FAR (Factor)		0.32	
Balance FAR Area		382.50	
BUILT UP AREA CHECK			
Total Proposed BuiltUp Area		101.85	
ARCHITECT (Regd)		RANJIT KUMAR	
ENGINEER (Regd)			
SUPERVISOR (Regd)			
OWNER (Regd)		TABASSUM AFSHAN	
DEVELOPMENT AUTHORITY		LOCAL BODY	

Building :A (BUILDING)

Floor Name	Total Built Up Area (Sq.mt.)	Proposed FAR Area (Sq.mt.) Resi.	Total FAR Area (Sq.mt.)	Total Consumed Additional FAR Area (Sq.mt.)	Tnmt (No.)
Ground Floor	101.85	101.85	101.85	101.85	01
Terrace Floor	0.00	0.00	0.00	0.00	00
Total :	101.85	101.85	101.85	101.85	01
Total Number of Same Buildings :	1				
Total :	101.85	101.85	101.85	101.85	01

SCHEDULE OF DOOR:

BUILDING NAME	NAME	LENGTH	HEIGHT	NOS
A (BUILDING)	D1	0.75	2.10	04
A (BUILDING)	D	0.90	2.10	04

SCHEDULE OF WINDOW/VENTILATION:

BUILDING NAME	NAME	LENGTH	HEIGHT	NOS
A (BUILDING)	V	0.90	0.60	02
A (BUILDING)	W	1.20	1.20	08

UnitBUA Table for Building :A (BUILDING)

FLOOR	Name	UnitBUA Type	UnitBUA Area	Carpet Area	No. of Rooms	No. of Tenement
GROUND FLOOR PLAN	SPLIT A	FLAT	93.54	93.33	10	1
Total:	-	-	93.54	93.33	10	1

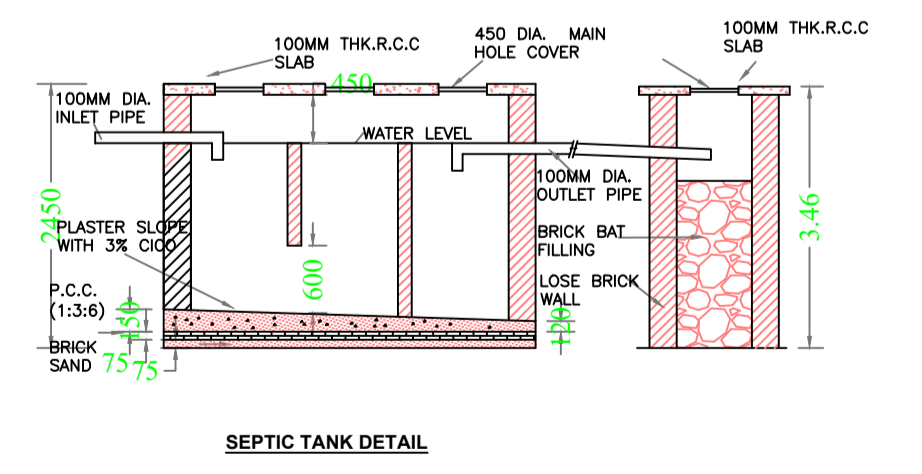
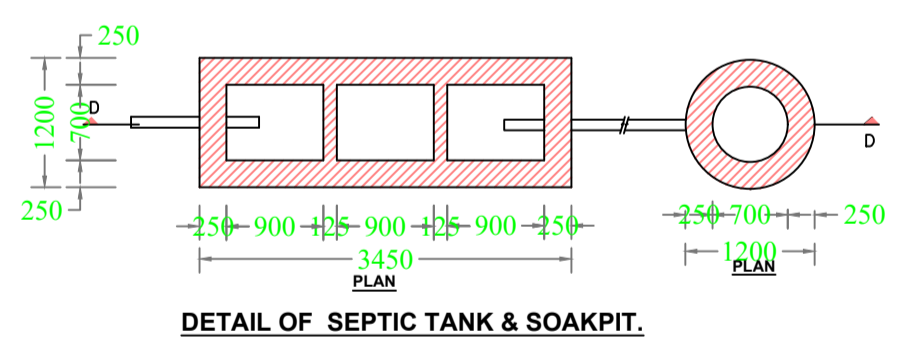
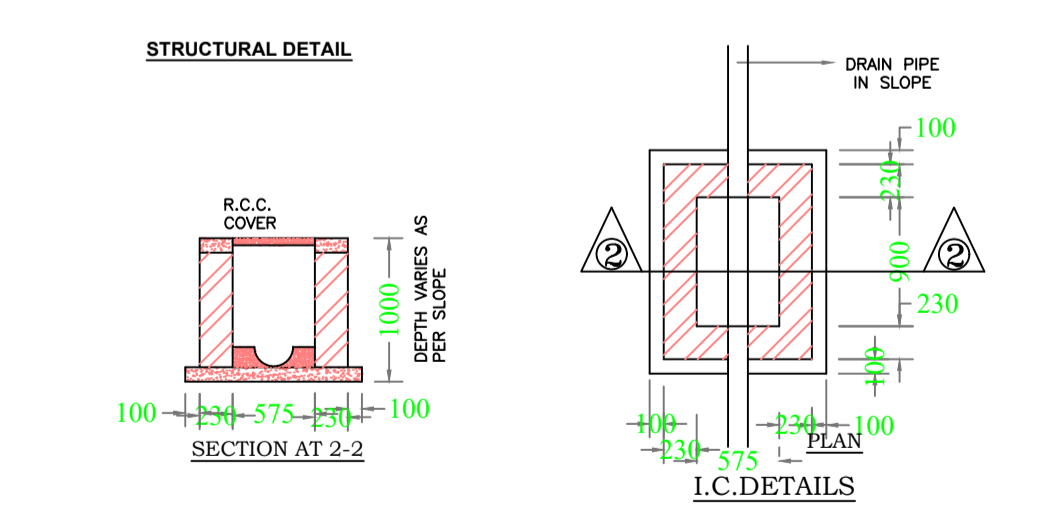
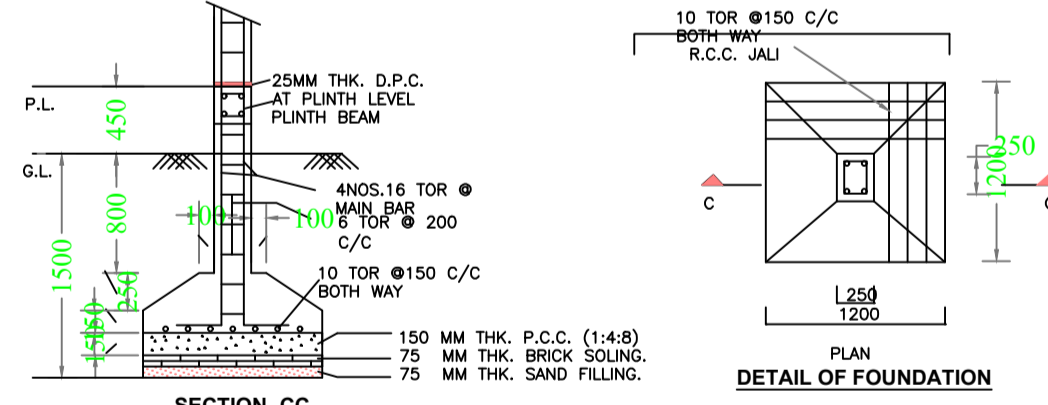
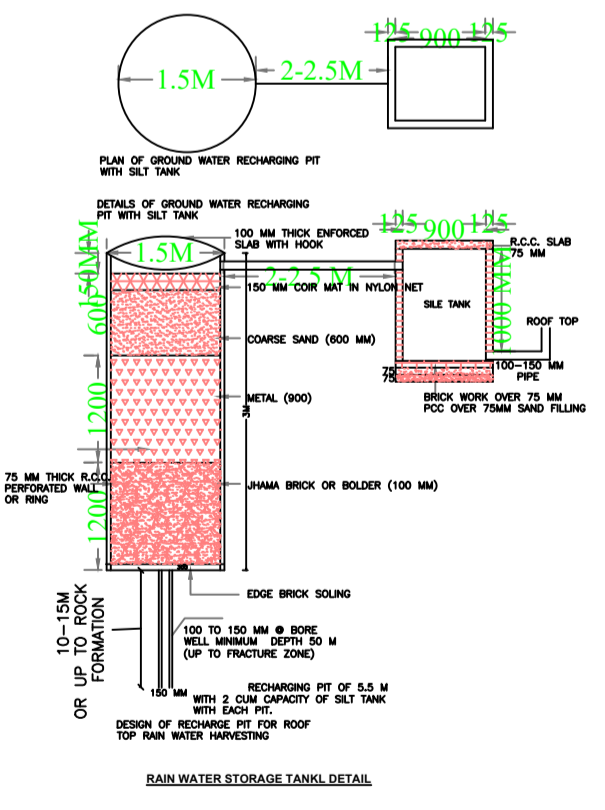

COLOR INDEX

PLOT BOUNDARY	Black
ABUTTING ROAD	Green
PROPOSED CONSTRUCTION	Red
COMMON PLOT	Yellow
ROAD WIDENING AREA	Orange
EXISTING (To be retained)	Blue
EXISTING (To be demolished)	Light Blue

Buildingwise Floor FAR Details

Floor Name	Building Name A (BUILDING)		Total	
	Proposed Built Up Area (Sq.mt.)	Proposed FAR Area (Sq.mt.)	Total Proposed Built Up Area (Sq.mt.)	Total FAR Area (Sq.mt.)
Ground Floor	101.85	101.85	101.85	101.85
Terrace Floor	0.00	0.00	0.00	0.00
Total :	101.85	101.85	101.85	101.85

Building USE/SUBUSE Details

Building Name	Building Use	Building SubUse	Building Structure
A (BUILDING)	Residential	Bungalow/ Dwelling / Non Apartment	Non-Highrise

FAR & Tenement Details (Table 4c-1)

Building	No. of Same Bldg	Total Built Up Area (Sq.mt.)	Proposed FAR Area (Sq.mt.) Resi.	Total FAR Area (Sq.mt.)	Total Consumed Additional FAR Area (Sq.mt.)	Tnmt (No.)
A (BUILDING)	1	101.85	101.85	101.85	101.85	01
Grand Total :	1	101.85	101.85	101.85	101.85	01

LTP NAME AND SIGNATURE	STRUCTURAL ENG'S NAME AND SIGNATURE	BUILDER NAME AND SIGNATURE	DIGITAL SIGNATURE
RANJIT KUMAR MNNP/ENG/0001/2016			