

FAR & Tenement Details (Table 4c-1)

Building	No. of Same Bldg	Total Built Up Area (Sq.mt.)	Deductions (Area in Sq.mt.)	Proposed FAR Area (Sq.mt.)	Total FAR Area (Sq.mt.)	Total Consumed Additional FAR Area (Sq.mt.)	Tnmt (No.)
A (BUILDING)	1	205.12	42.93	162.19	162.19	162.19	01
Grand Total :	1	205.12	42.93	162.19	162.19	162.19	01

Proposal Basic Information

Proposal File No.	MNNP/BP/0117/W13/2021
Owner Name	ASHA DEVI
Khata No	72
Plot No	397
Village Name	Sudna
Use	Residential
SubUse	Bungalow/ Dwelling / Non Apartment

AREA STATEMENT	VERSION NO. : 1.0.62		
MEDININAGAR MUNICIPAL CORPORATION	VERSION DATE: 16/10/2020		
PROJECT DETAIL:			
Region: JHARKHAND URBAN LOCAL BODIES	Plot Use: Residential		
District: PALAMU	Plot SubUse: Bungalow/ Dwelling / Non Apartment		
Authority: MEDININAGAR MUNICIPAL CORPORATION	PlotNearby/Religious/Structure: NA		
Inward No: MNNP/BP/0117/W13/2021	Plot/SubPlot No: 397		
Application Type: General Proposal	North: -		
Project Type: Building Permission	South: -		
Nature of Development: New	East: -		
Location of Development Area: Old Area	West: -		
AREA DETAILS:			
AREA OF PLOT (Minimum)	(A)	SQ.MT.	159.27
Deduction for NetPlot Area			
Surrender Free of Cost			9.95
Total			9.95
NET AREA OF PLOT(Gross Plot Area - Deduction from Gross Plot area)	(A-Deductions)		149.32
Deduction for Balance Plot Area(from Gross Plot Area)			
Surrender Free of Cost			9.95
Common Plot			9.85
Total			19.80
BALANCE AREA OF PLOT(Net Plot Area - Recreational/Amenity space)	(A-Deductions)		139.47
PLOT AREA FOR COVERAGE(Net Plot Area)	(A-Deductions)		149.32
Plot Area for FAR (Net Plot Area + Road/Widening Area)	(A-Deductions)		159.27
COVERAGE CHECK			
Permissible Coverage area (70.00 %)			104.52
Proposed Coverage Area (68.68 %)			102.56
Total Prop. Coverage Area (68.68 %)			102.56
Balance coverage area (1.31 %)			1.96
FAR CHECK			
Perm. FAR Area (1.20)			191.12
Total Perm. FAR area			191.12
Residential FAR			162.20
Proposed FAR Area			162.20
Total Proposed FAR Area			162.20
Consumed FAR (Factor)			1.02
Balance FAR Area			28.92
BUILT UP AREA CHECK			
Total Proposed BuiltUp Area			205.12
ARCHITECT (Regd)		RANJIT KUMAR	
ENGINEER (Regd)			
SUPERVISOR (Regd)			
OWNER (Regd)		ASHA DEVI	
DEVELOPMENT AUTHORITY		LOCAL BODY	

COLOR INDEX	
PLOT BOUNDARY	Black
ABUTTING ROAD	Green
PROPOSED CONSTRUCTION	Red
COMMON PLOT	Yellow
ROAD WIDENING AREA	Blue
EXISTING (To be retained)	Light Blue
EXISTING (To be demolished)	Light Yellow

Buildingwise Floor FAR Details

Floor Name	Building Name		Total	
	Proposed Built Up Area (Sq.mt.)	Proposed FAR Area (Sq.mt.)	Total Proposed Built Up Area (Sq.mt.)	Total FAR Area (Sq.mt.)
Ground Floor	102.56	59.63	102.56	59.63
First Floor	102.56	102.56	102.56	102.56
Terrace Floor	0.00	0.00	0.00	0.00
Total :	205.12	162.19	205.12	162.19

Building USE/SUBUSE Details

Building Name	Building Use	Building SubUse	Building Structure
A (BUILDING)	Residential	Bungalow/ Dwelling / Non Apartment	Non-Highrise

LTP NAME AND SIGNATURE	STRUCTURAL ENG'S NAME AND SIGNATURE	BUILDER NAME AND SIGNATURE	DIGITAL SIGNATURE
RANJIT KUMAR MNNP/ENG/0001/2016			



Proposal Basic Information	
Proposal File No.	MNNP/BP/0117/W13/2021
Owner Name	ASHA DEVI
Khata No	72
Plot No	397
Village Name	Sudna
Use	Residential
SubUse	Bungalow/ Dwelling / Non Apartment

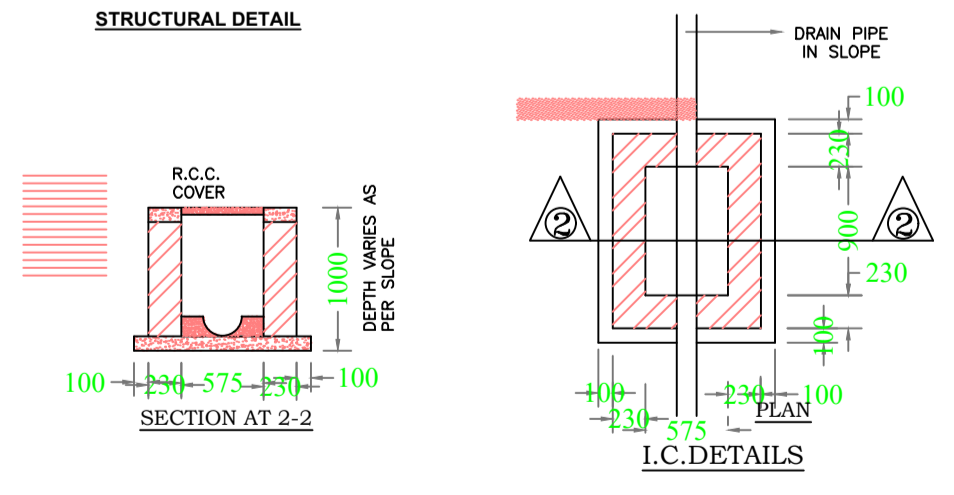
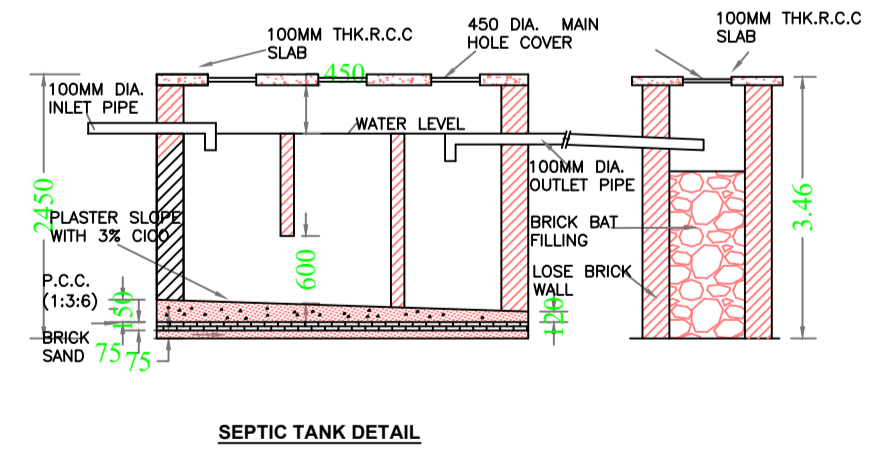
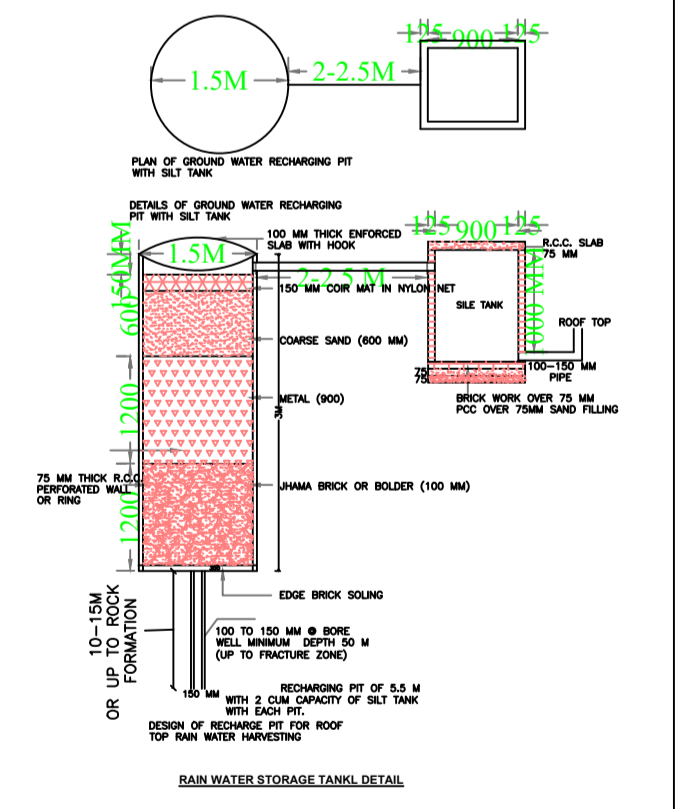
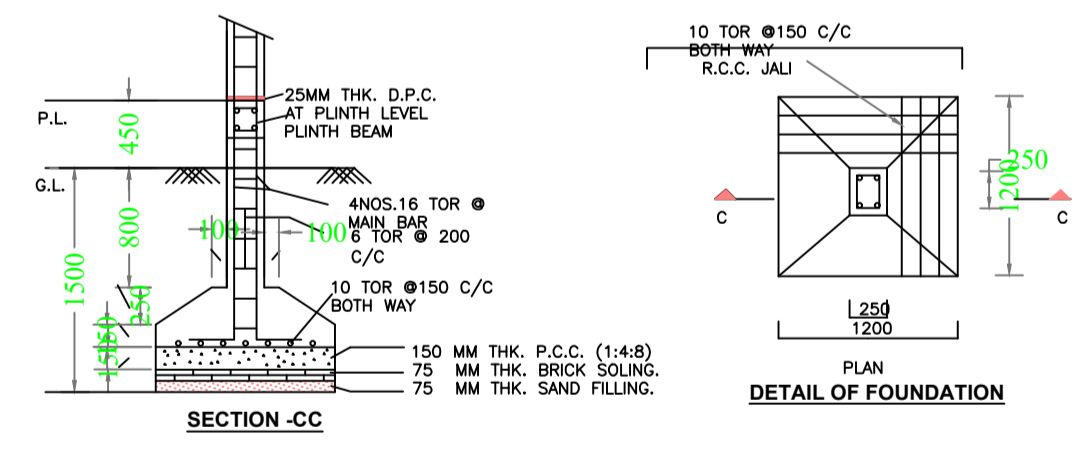
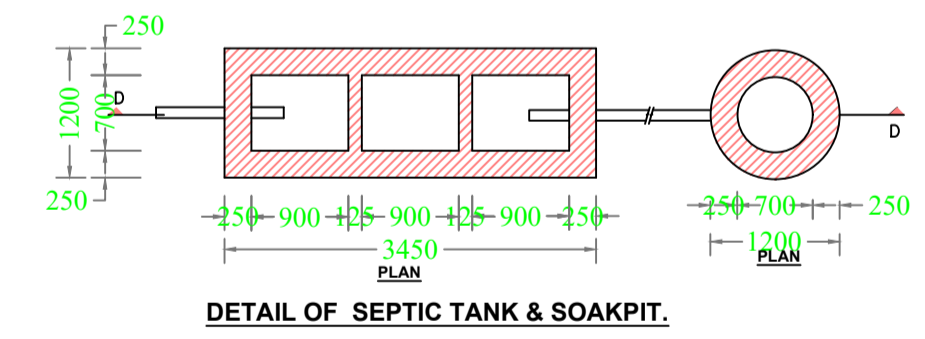
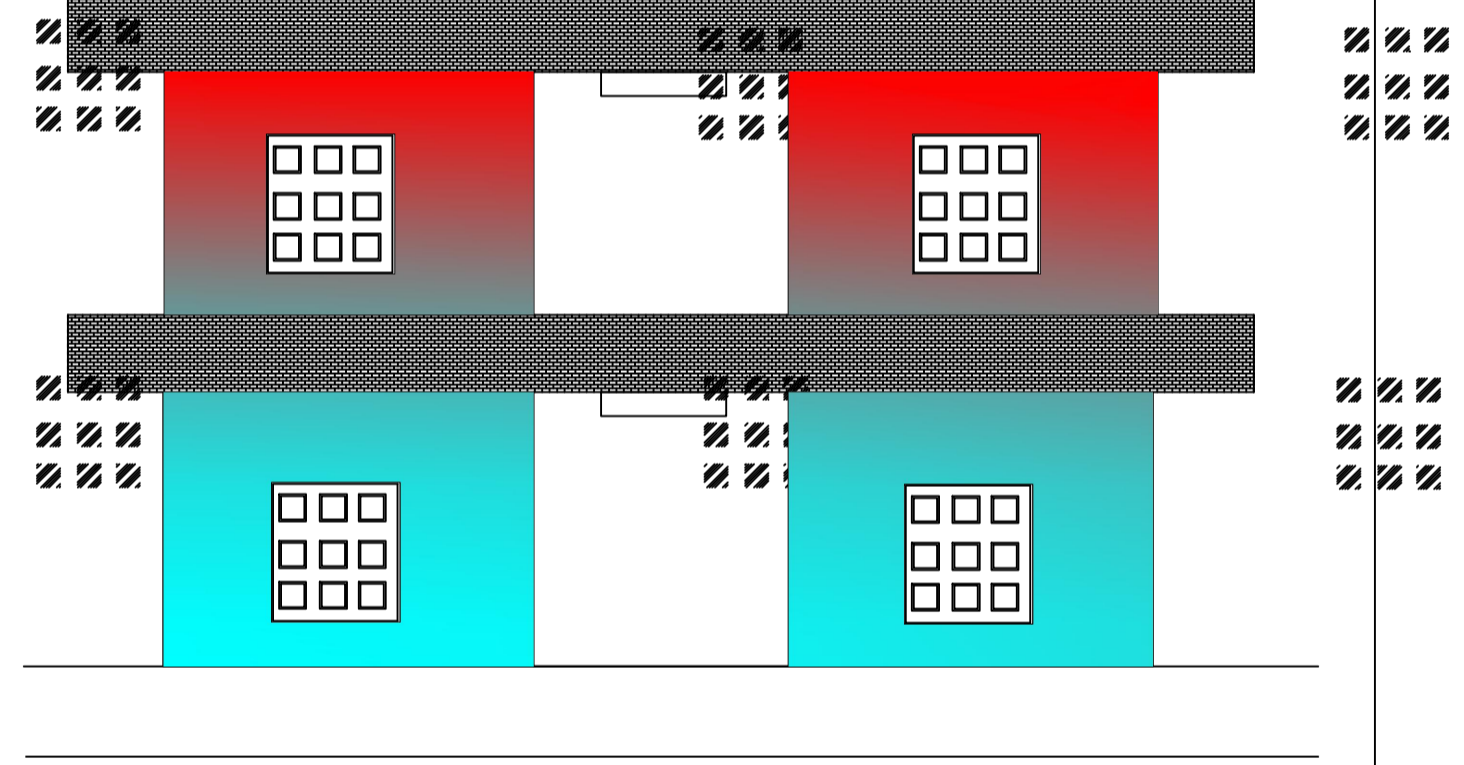
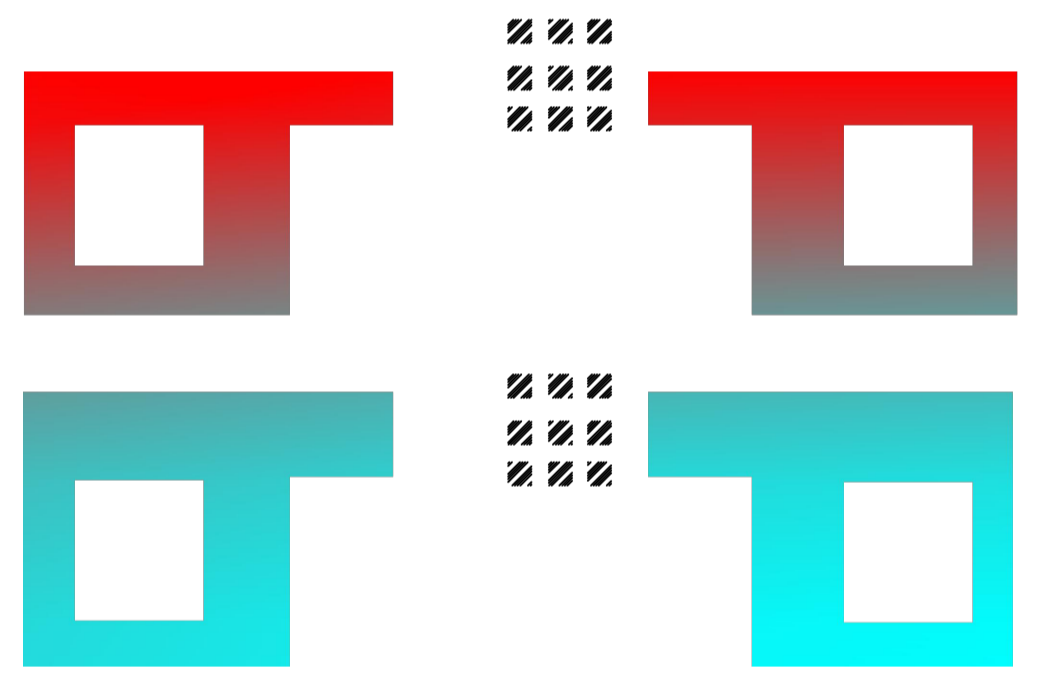
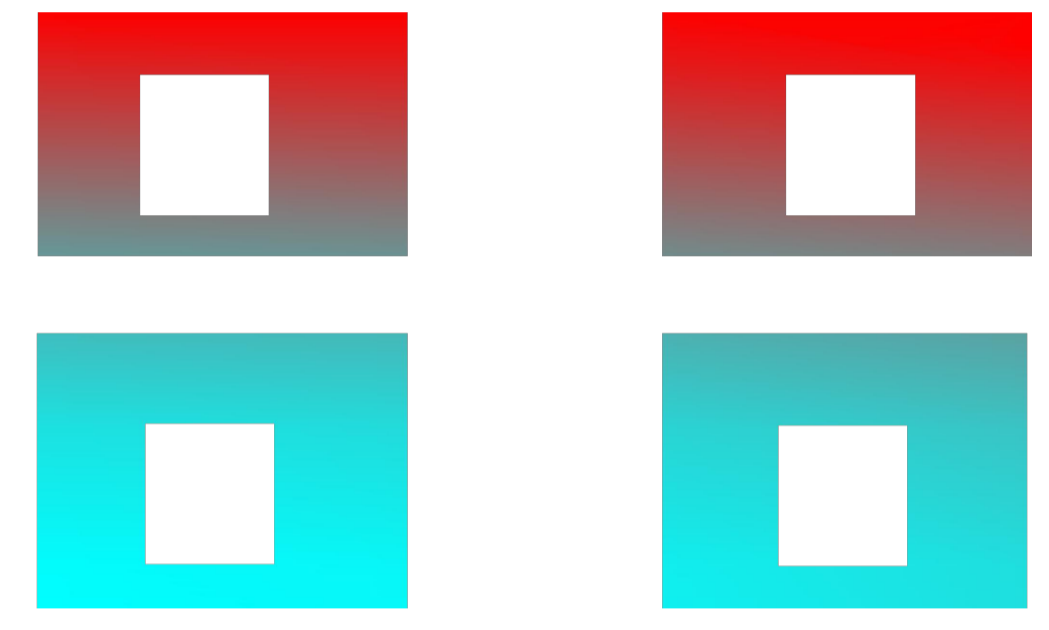
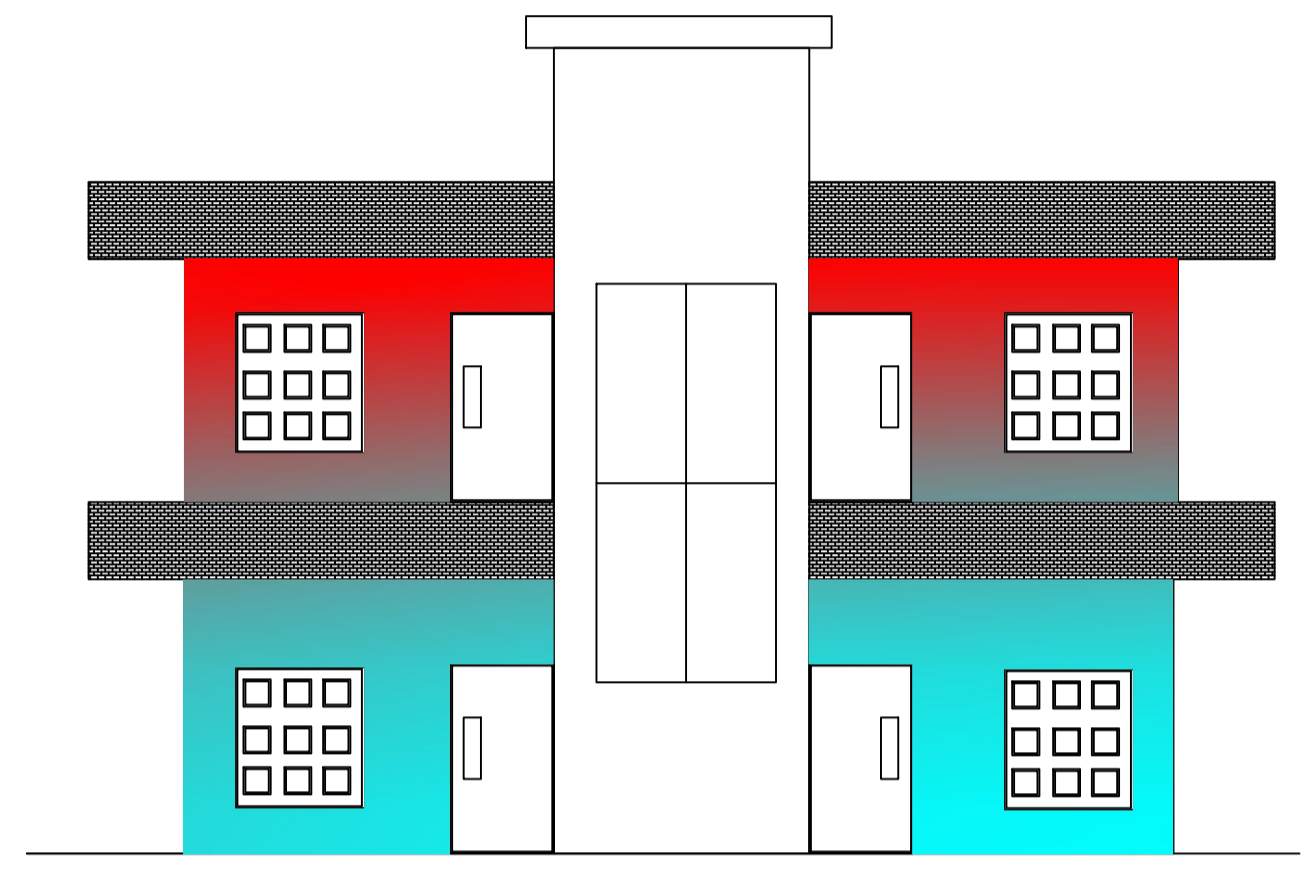
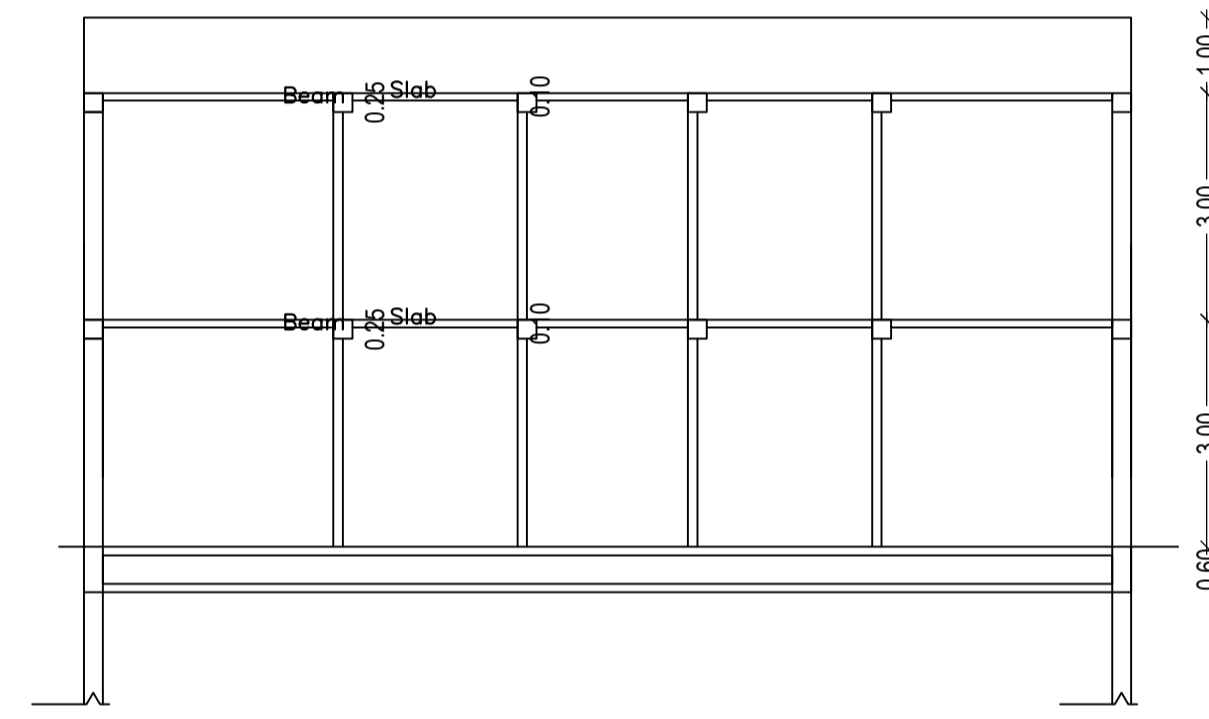
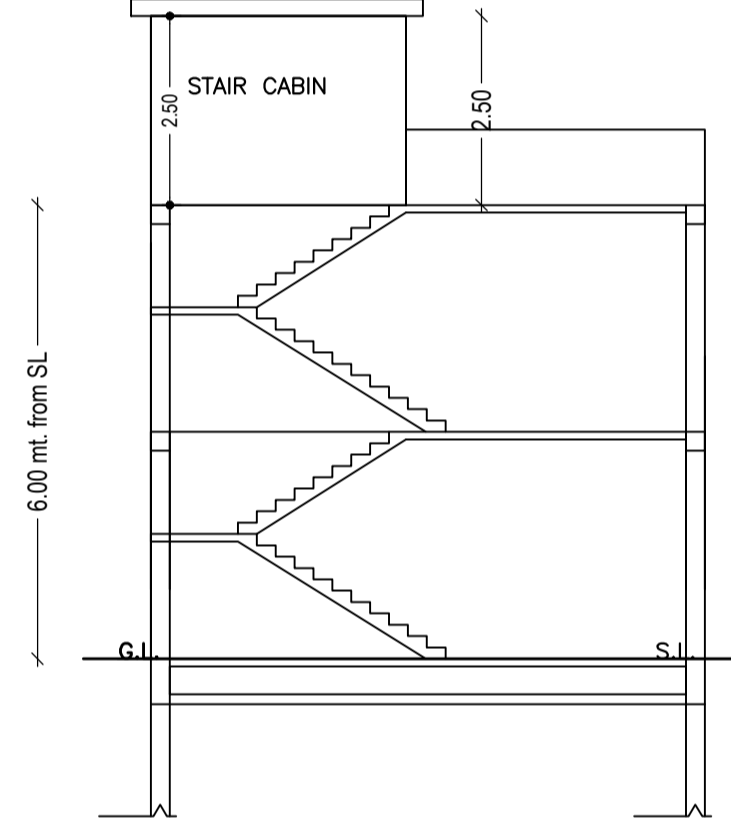
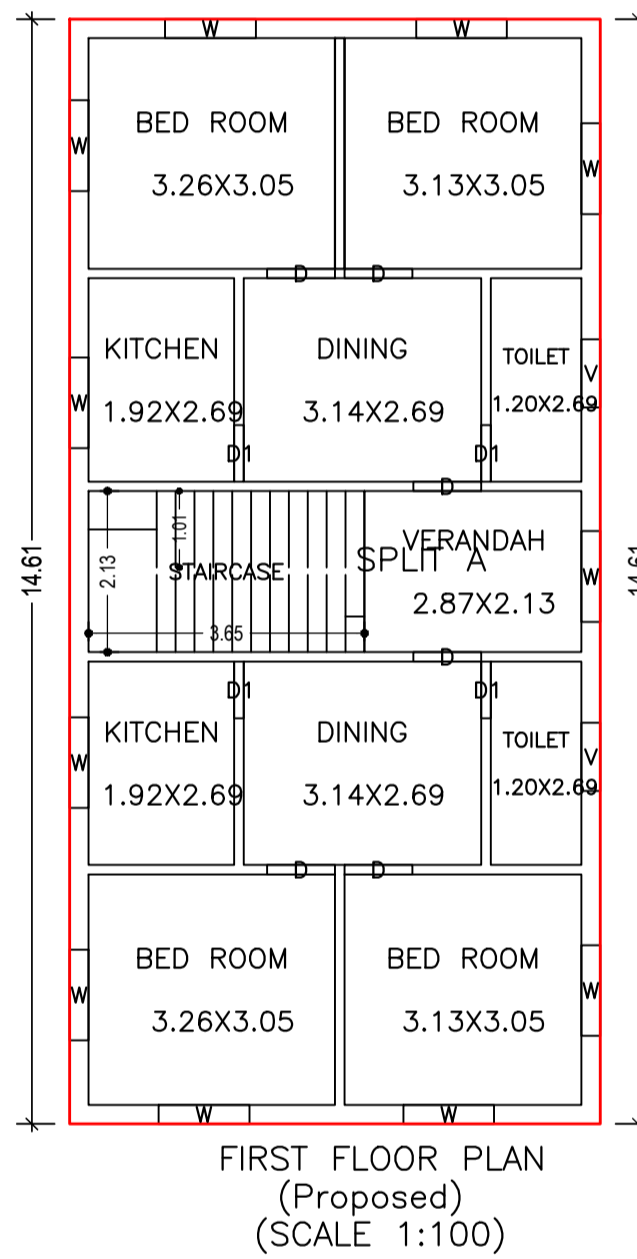
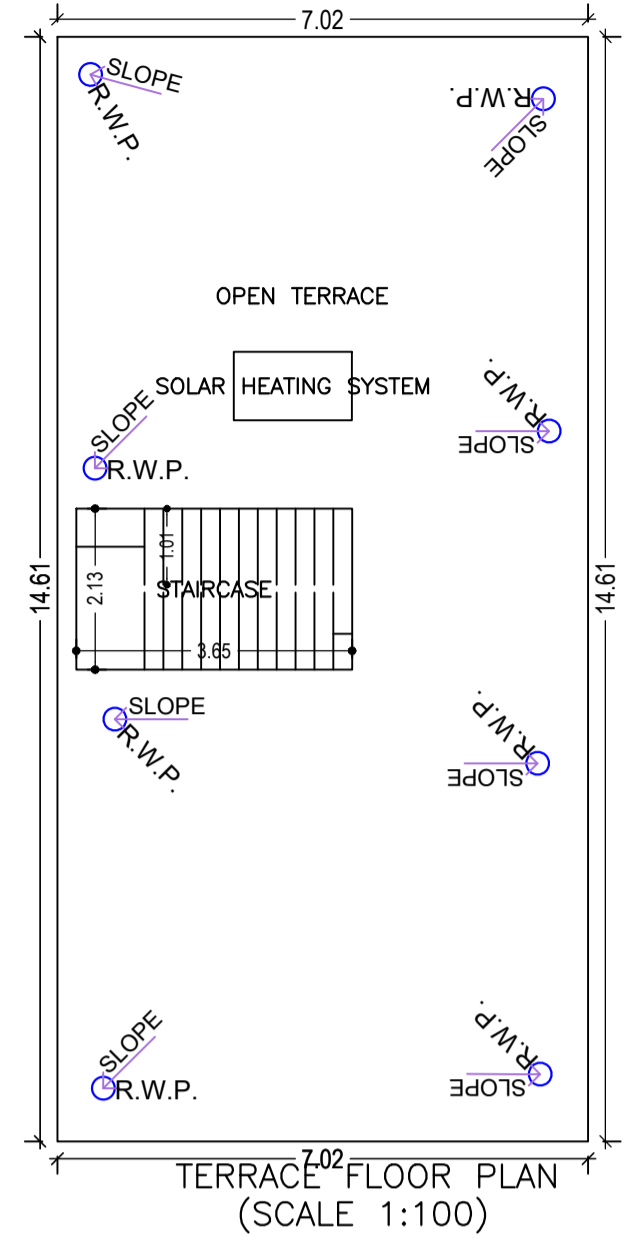
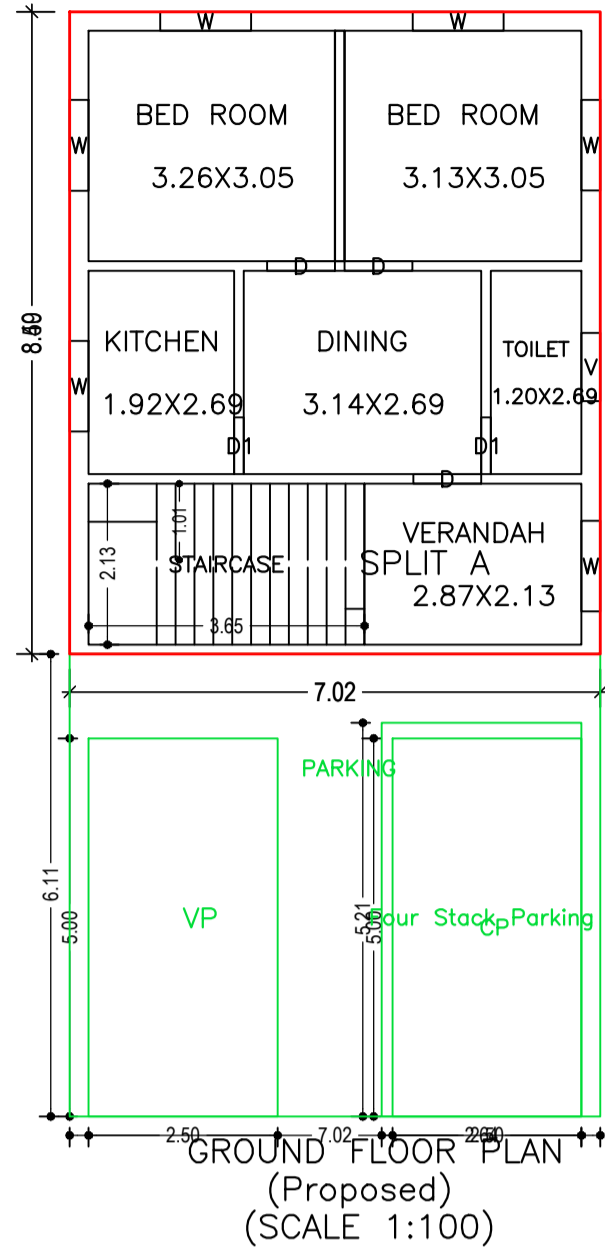

Building :A (BUILDING)

Floor Name	Total Built Up Area (Sq.mt.)	Deductions (Area in Sq.mt.)	Proposed FAR Area (Sq.mt.)	Total FAR Area (Sq.mt.)	Total Consumed Additional FAR Area (Sq.mt.)	Tnmt (No.)
Ground Floor	102.56	42.93	59.63	59.63	59.63	01
First Floor	102.56	0.00	102.56	102.56	102.56	00
Terrace Floor	0.00	0.00	0.00	0.00	0.00	00
Total:	205.12	42.93	162.19	162.19	162.19	01
Total Number of Same Buildings	1					
Total:	205.12	42.93	162.19	162.19	162.19	01

SCHEDULE OF DOOR:

BUILDING NAME	NAME	LENGTH	HEIGHT	NOS
A (BUILDING)	D1	0.75	2.10	06
A (BUILDING)	D	0.90	2.10	09

SCHEDULE OF WINDOW/VENTILATION:

BUILDING NAME	NAME	LENGTH	HEIGHT	NOS
A (BUILDING)	V	0.90	0.60	03
A (BUILDING)	W	1.20	1.20	17

UnitBUA Table for Building :A (BUILDING)

FLOOR	Name	UnitBUA Type	UnitBUA Area	Carpet Area	No. of Rooms	No. of Tenement
GROUND FLOOR	SPLIT A	FLAT	145.58	144.82	6	1
FIRST FLOOR	SPLIT A	FLAT	0.00	0.00	11	0
Total:	-	-	145.58	144.82	17	1

LTP NAME AND SIGNATURE	STRUCTURAL ENG'S NAME AND SIGNATURE	BUILDER NAME AND SIGNATURE	DIGITAL SIGNATURE
RANJIT KUMAR MNNP/ENG/0001/2016			