

Building :A (BUILDING)

Floor Name	Total Built Up Area (Sq.mt.)	Proposed FAR Area (Sq.mt.) Resi.	Total FAR Area (Sq.mt.)	Total Consumed Additional FAR Area (Sq.mt.)	Tnmt (No.)
Ground Floor	128.77	128.77	128.77	128.77	01
First Floor	128.77	128.77	128.77	128.77	00
Terrace Floor	0.00	0.00	0.00	0.00	00
Total:	257.54	257.54	257.54	257.54	01
Total Number of Same Buildings	1				
Total:	257.54	257.54	257.54	257.54	01

SCHEDULE OF DOOR:

BUILDING NAME	NAME	LENGTH	HEIGHT	NOS
A (BUILDING)	D1	0.75	2.10	04
A (BUILDING)	D	0.90	2.10	06

SCHEDULE OF WINDOW/VENTILATION:

BUILDING NAME	NAME	LENGTH	HEIGHT	NOS
A (BUILDING)	V	0.90	0.60	02
A (BUILDING)	W	1.20	1.20	30

UnitBUA Table for Building :A (BUILDING)

FLOOR	Name	UnitBUA Type	UnitBUA Area	Carpet Area	No. of Rooms	No. of Tenement
GROUND FLOOR PLAN	SPLIT A	FLAT	240.92	240.59	6	1
FIRST FLOOR PLAN	SPLIT A	FLAT	0.00	0.00	6	0
Total:	-	-	240.92	240.59	12	1

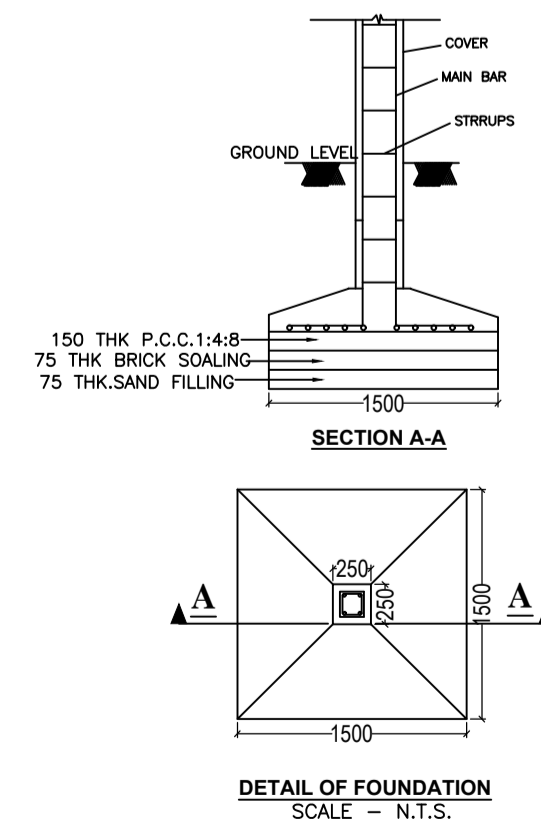
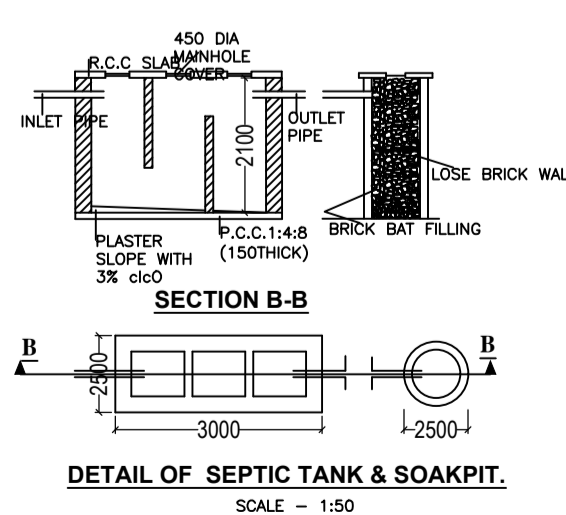
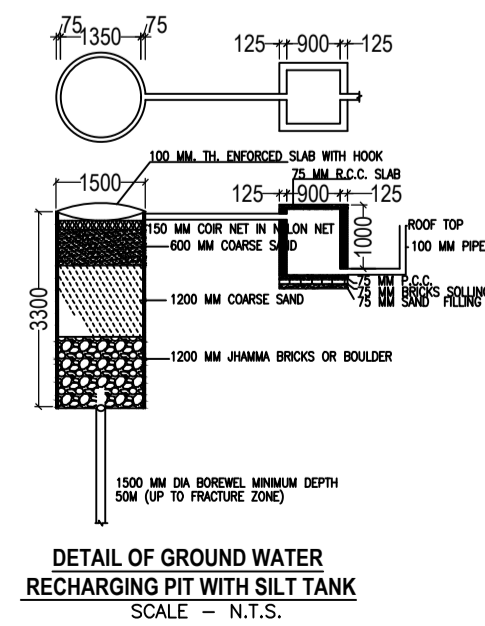

Proposal Basic Information

Proposal File No.	MNNP/BP/0129/W08/2021
Owner Name	PRAMILA DEVI , ASHOK KUMAR , JAGO DEVI
Khata No	32
Plot No	21
Village Name	Baralota Rodma
Use	Residential
SubUse	Bungalow/ Dwelling / Non Apartment

AREA STATEMENT	VERSION NO.: 1.0.61	SQ.MT.
AREA OF PLOT (Minimum)	(A)	261.89
NET AREA OF PLOT (Gross Plot Area - Deduction from Gross Plot Area)	(A-Deductions)	261.89
Deduction for Balance Plot Area (from Gross Plot Area)		
Common Plot		16.58
Total		16.58
BALANCE AREA OF PLOT (Net Plot Area - Recreational/Amenity space)	(A-Deductions)	245.31
PLOT AREA FOR COVERAGE (Net Plot Area)	(A-Deductions)	261.89
Plot Area for FAR (Net Plot Area + Road Widening Area)	(A-Deductions)	261.89
COVERAGE CHECK		
Permissible Coverage area (60.00 %)		157.13
Proposed Coverage Area (49.17 %)		128.77
Total Prop. Coverage Area (49.17 %)		128.77
Balance coverage area (10.83 %)		28.36
FAR CHECK		
Perm. FAR Area (1.80)		471.40
Total Perm. FAR area		471.40
Residential FAR		257.54
Proposed FAR Area		257.54
Total Proposed FAR Area		257.54
Consumed FAR (Factor)		0.98
Balance FAR Area		213.86
BUILT UP AREA CHECK		
Total Proposed BuiltUp Area		257.54
ARCHITECT (Regd)	RANJIT KUMAR	
ENGINEER (Regd)		
SUPERVISOR (Regd)		
OWNER (Regd)	PRAMILA DEVI , ASHOK KUMAR , JAGO DEVI	
DEVELOPMENT AUTHORITY	LOCAL BODY	

COLOR INDEX

PLOT BOUNDARY	Black
ABUTTING ROAD	Red
PROPOSED CONSTRUCTION	Green
COMMON PLOT	Yellow
ROAD WIDENING AREA	Blue
EXISTING (To be retained)	Orange
EXISTING (To be demolished)	Light Blue

Buildingwise Floor FAR Details

Floor Name	Building Name A (BUILDING)		Total	
	Proposed Built Up Area (Sq.mt.)	Proposed FAR Area (Sq.mt.)	Total Proposed Built Up Area (Sq.mt.)	Total FAR Area (Sq.mt.)
Ground Floor	128.77	128.77	128.77	128.77
First Floor	128.77	128.77	128.77	128.77
Terrace Floor	0.00	0.00	0.00	0.00
Total:	257.54	257.54	257.54	257.54

Building USE/SUBUSE Details

Building Name	Building Use	Building SubUse	Building Structure
A (BUILDING)	Residential	Bungalow/ Dwelling / Non Apartment	Non-Highrise

FAR & Tenement Details (Table 4c-1)

Building	No. of Same Bldg	Total Built Up Area (Sq.mt.)	Proposed FAR Area (Sq.mt.) Resi.	Total FAR Area (Sq.mt.)	Total Consumed Additional FAR Area (Sq.mt.)	Tnmt (No.)
A (BUILDING)	1	257.54	257.54	257.54	257.54	01
Grand Total	1	257.54	257.54	257.54	257.54	01

LTP NAME AND SIGNATURE	STRUCTURAL ENG'S NAME AND SIGNATURE	BUILDER NAME AND SIGNATURE	DIGITAL SIGNATURE
RANJIT KUMAR MNNP/ENG/0001/2016			