

SITE PLAN  
site plan

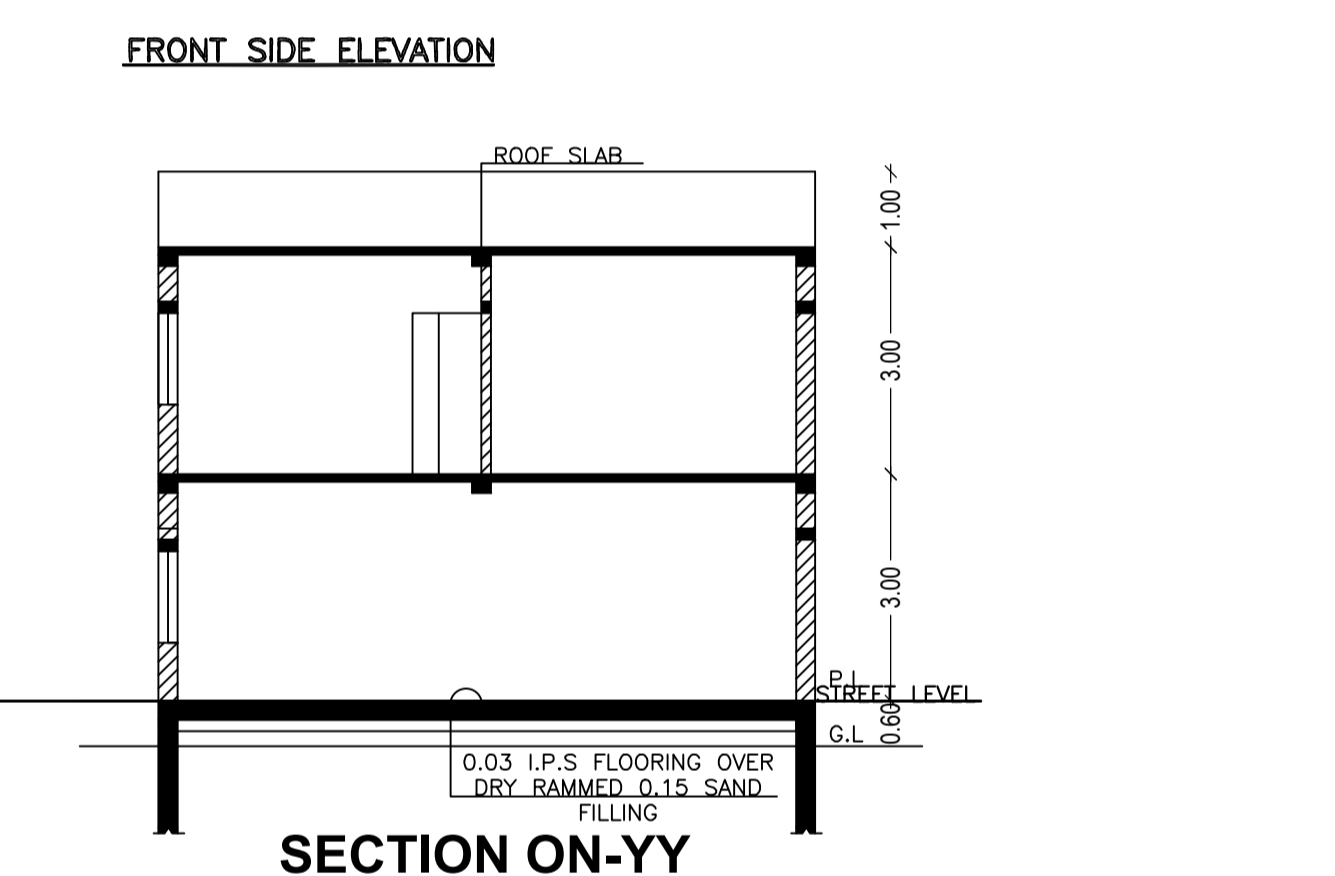
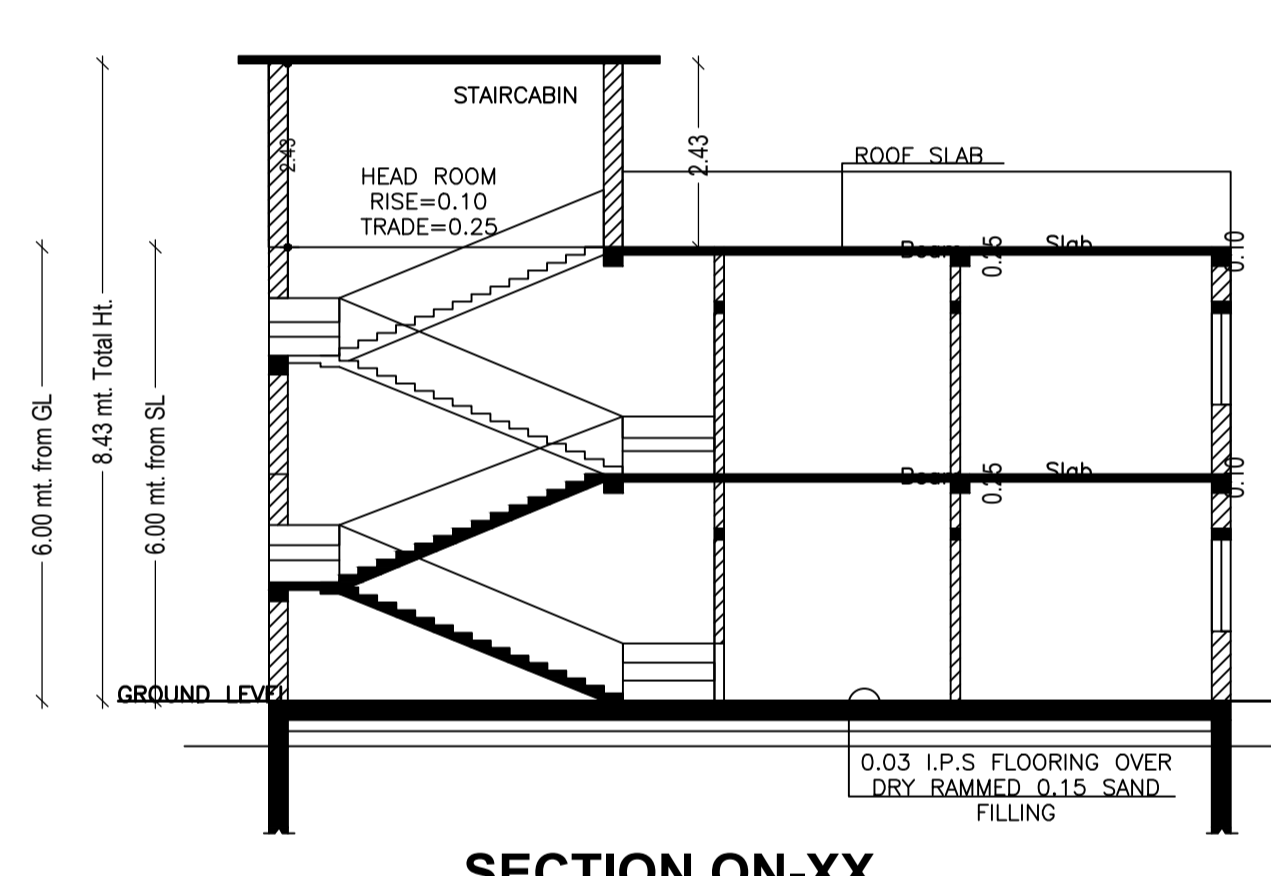
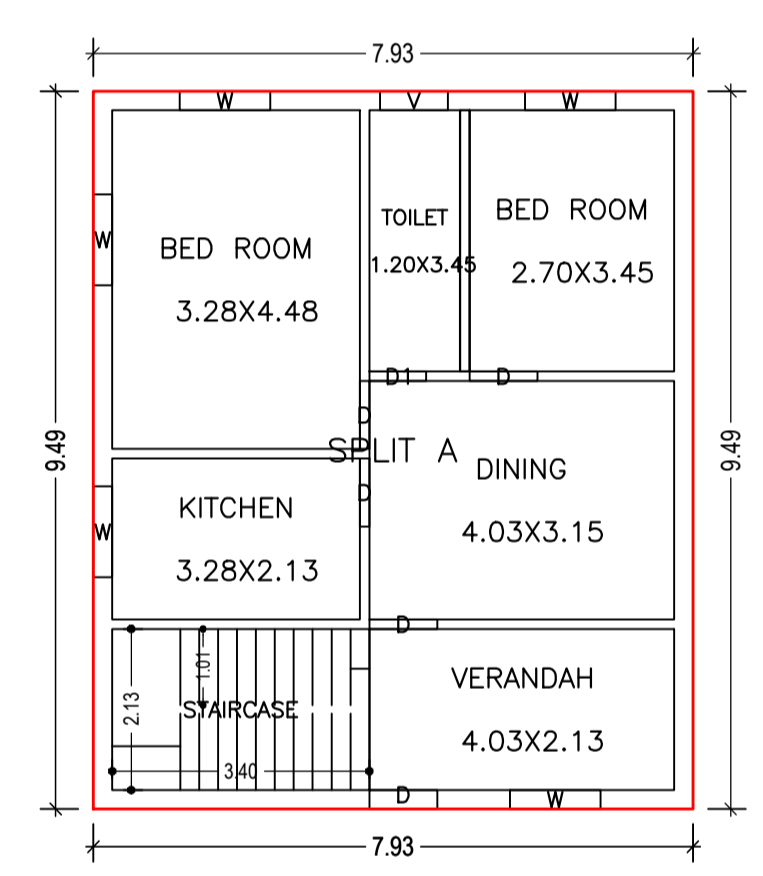
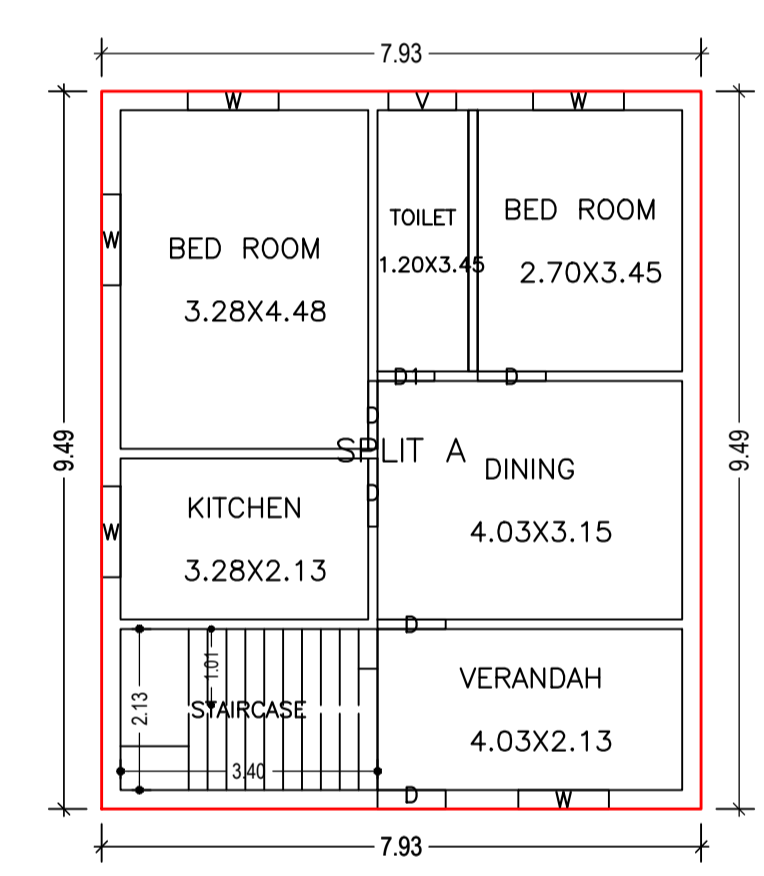

FAR & Tenement Details (Table 4c-1)

Building	No. of Same Bldg	Total Built Up Area (Sq.mt.)	Proposed FAR Area (Sq.mt.) Resi.	Total FAR Area (Sq.mt.)	Total Consumed Additional FAR Area (Sq.mt.)	Tnmt (No.)
A (BUILDING)	1	150.52	150.52	150.52	150.52	01
Grand Total :	1	150.52	150.52	150.52	150.52	01

Proposal Basic Information

Proposal File No.	MNNP/BI/0142/W06/2022
Owner Name	Gita Devi
Khata No	53
Plot No	923
Village Name	Baralota Rodma
Use	Residential
SubUse	Bungalow/ Dwelling / Non Apartment

AREA STATEMENT  
MEDININAGAR MUNICIPAL CORPORATION  
VERSION NO.: 1.0.62  
VERSION DATE: 16/10/2020

AREA DETAILS:		SQ.MT.
AREA OF PLOT (Minimum)	(A)	121.06
Deduction for NetPlot Area		
Surrender Free of Cost		6.36
Total		6.36
NET AREA OF PLOT(Gross Plot Area - Deduction from Gross Plot area)	(A-Deductions)	114.70
Deduction for Balance Plot Area(from Gross Plot Area)		
Surrender Free of Cost		6.36
Common Plot		13.13
Total		19.49
BALANCE AREA OF PLOT(Net Plot Area - Recreational/Amenity space)	(A-Deductions)	101.57
PLOT AREA FOR COVERAGE(Net Plot Area)	(A-Deductions)	114.70
Plot Area for FAR (Net Plot Area + Road/Widening Area)	(A-Deductions)	121.06
COVERAGE CHECK		
Permissible Coverage area ( 70.00 % )		80.29
Proposed Coverage Area ( 65.61 % )		75.26
Total Prop. Coverage Area ( 65.61 % )		75.26
Balance coverage area ( 4.39 % )		5.03
FAR CHECK		
Perm. FAR Area ( 1.50 )		181.59
Total Perm. FAR area		181.59
Residential FAR		150.51
Proposed FAR Area		150.51
Total Proposed FAR Area		150.51
Consumed FAR (Factor)		1.24
Balance FAR Area		31.08
BUILT UP AREA CHECK		
Total Proposed BuiltUp Area		150.52
ARCHITECT (Regd)	PANKAJ KUMAR SINGH	
ENGINEER (Regd)		
SUPERVISOR (Regd)		
OWNER (Regd)	Gita Devi	
DEVELOPMENT AUTHORITY	LOCAL BODY	

COLOR INDEX

PLOT BOUNDARY	Black
ABUTTING ROAD	Green
PROPOSED CONSTRUCTION	Red
COMMON PLOT	Yellow
ROAD WIDENING AREA	Blue
EXISTING (To be retained)	Orange
EXISTING (To be demolished)	White

Building :A (BUILDING)

Floor Name	Total Built Up Area (Sq.mt.)	Proposed FAR Area (Sq.mt.) Resi.	Total FAR Area (Sq.mt.)	Total Consumed Additional FAR Area (Sq.mt.)	Tnmt (No.)
Ground Floor	75.26	75.26	75.26	75.26	01
First Floor	75.26	75.26	75.26	75.26	00
Terrace Floor	0.00	0.00	0.00	0.00	00
Total :	150.52	150.52	150.52	150.52	01
Total Number of Same Buildings	1				
Total :	150.52	150.52	150.52	150.52	01

SCHEDULE OF DOOR:

BUILDING NAME	NAME	LENGTH	HEIGHT	NOS
A (BUILDING)	D1	0.75	2.10	02
A (BUILDING)	D	0.90	2.10	10

SCHEDULE OF WINDOW/VENTILATION:

BUILDING NAME	NAME	LENGTH	HEIGHT	NOS
A (BUILDING)	V	0.90	0.60	02
A (BUILDING)	W	1.20	1.20	10

UnitBUA Table for Building :A (BUILDING)

FLOOR	Name	UnitBUA Type	UnitBUA Area	Carpet Area	No. of Rooms	No. of Tenement
GROUND FLOOR PLAN	SPLIT A	FLAT	133.14	132.27	6	1
FIRST FLOOR PLAN	SPLIT A	FLAT	0.00	0.00	6	0
Total:	-	-	133.14	132.27	12	1

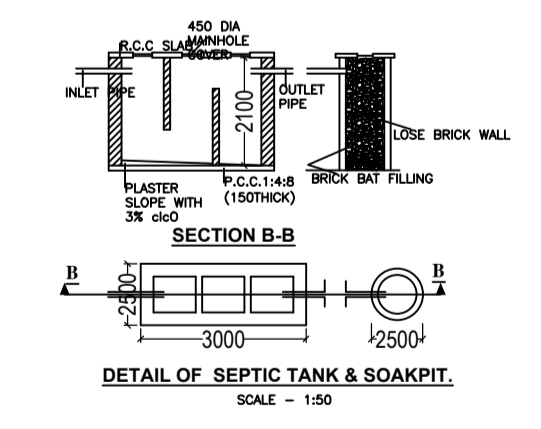

Buildingwise Floor FAR Details

Floor Name	Building Name A (BUILDING)		Total	
	Proposed Built Up Area (Sq.mt.)	Proposed FAR Area (Sq.mt.)	Total Proposed Built Up Area (Sq.mt.)	Total FAR Area (Sq.mt.)
Ground Floor	75.26	75.26	75.26	75.26
First Floor	75.26	75.26	75.26	75.26
Terrace Floor	0.00	0.00	0.00	0.00
Total :	150.52	150.52	150.52	150.52

Building USE/SUBUSE Details

Building Name	Building Use	Building SubUse	Building Structure
A (BUILDING)	Residential	Bungalow/ Dwelling / Non Apartment	Non-Highrise

LTP NAME AND SIGNATURE	STRUCTURAL ENG'S NAME AND SIGNATURE	BUILDER NAME AND SIGNATURE	DIGITAL SIGNATURE
PANKAJ KUMAR SINGH MNNP/ENG/0006/2019			