

Proposal Basic Information	
Proposal File No	MNNP/BP/0245/W33/2022
Owner Name	IRSAD SHAH
Khata No	95
Plot No	1368
Village Name	Bazar Muhalla Shapur
Use	Residential
SubUse	Bungalow/ Dwelling / Non Apartment

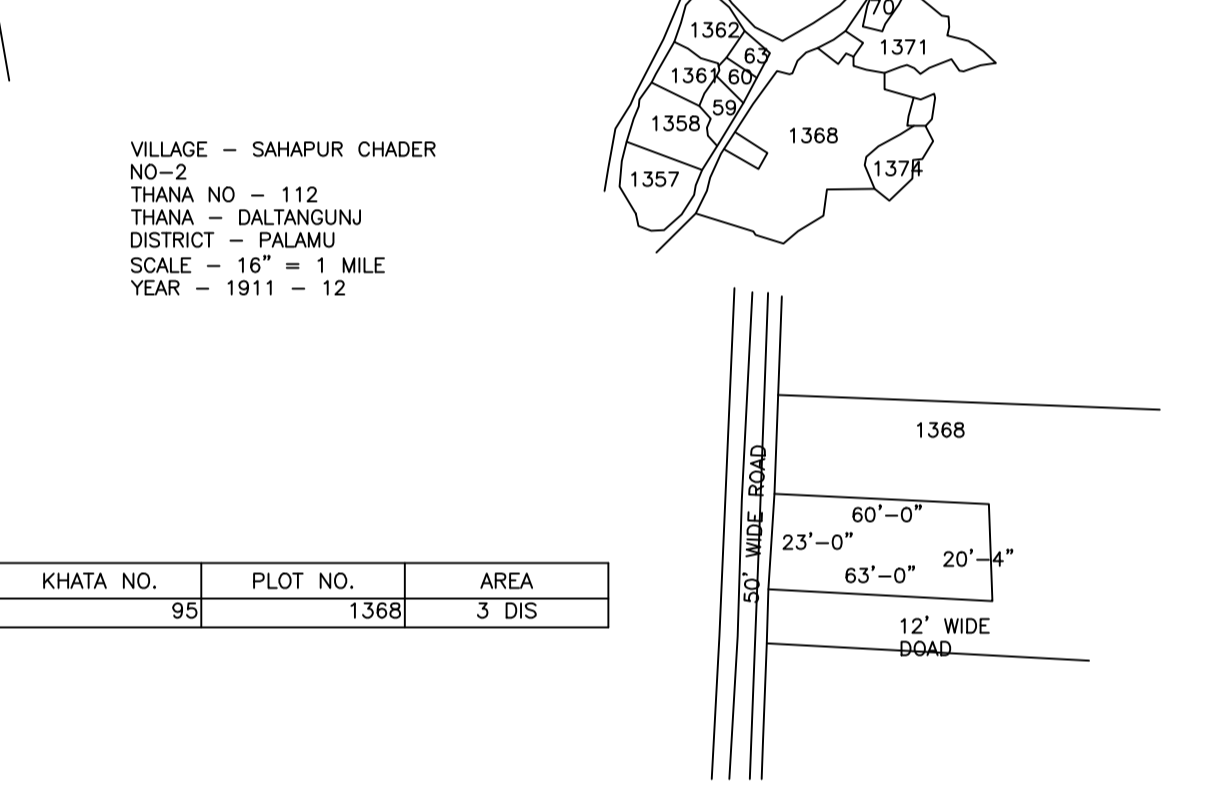
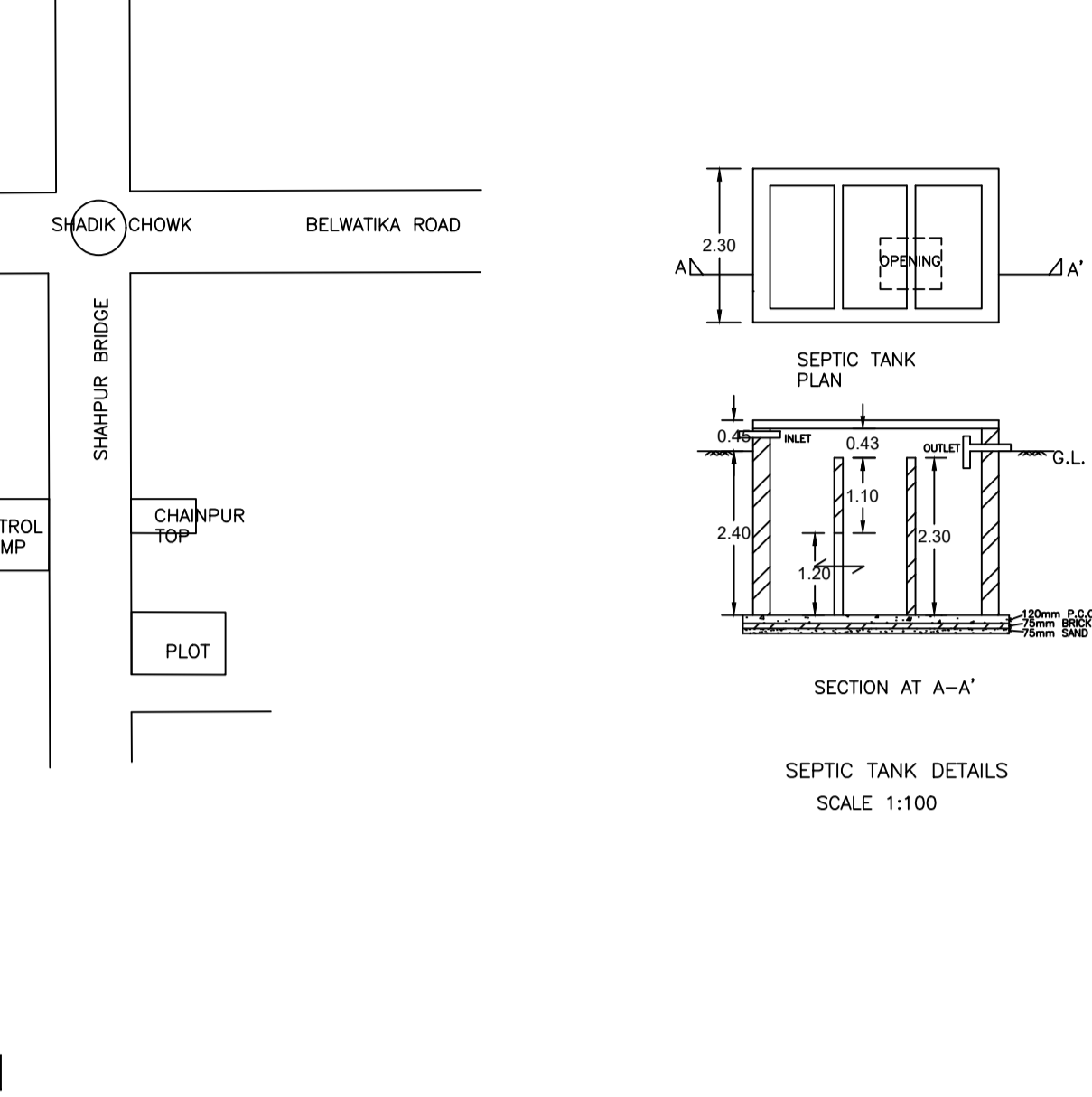
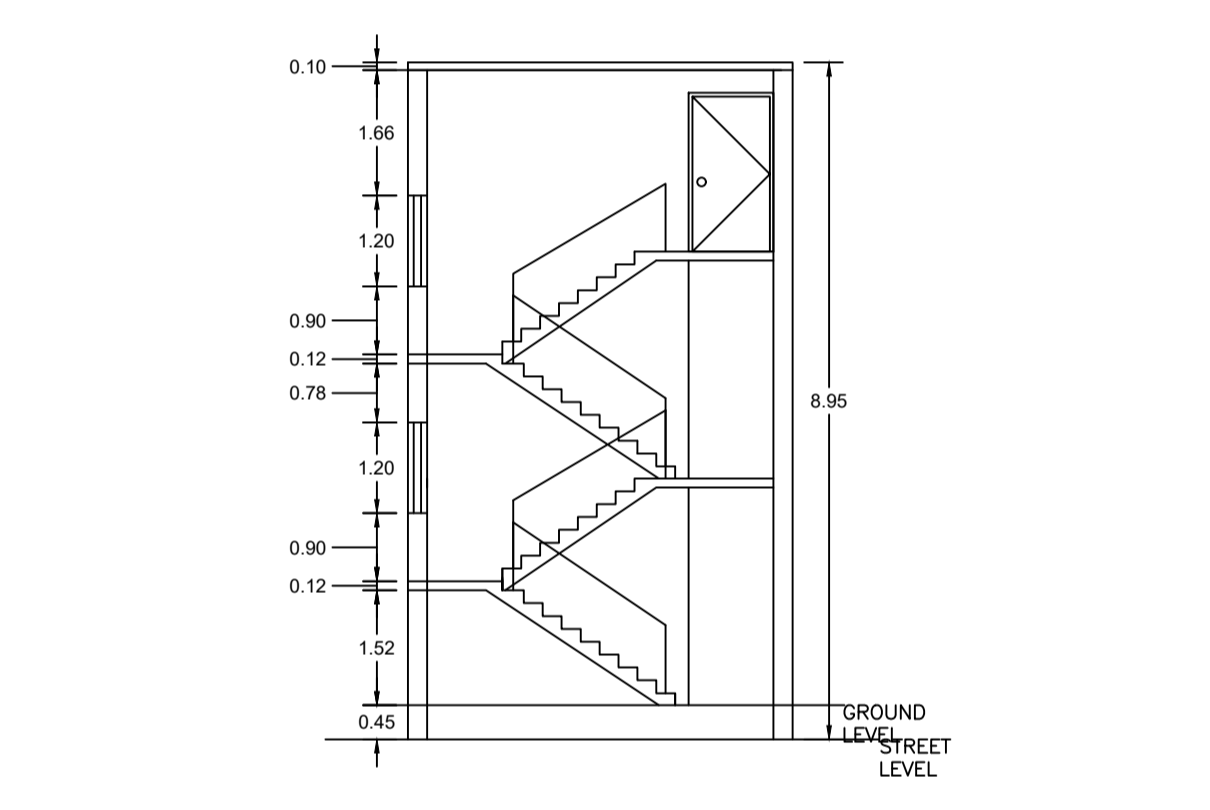
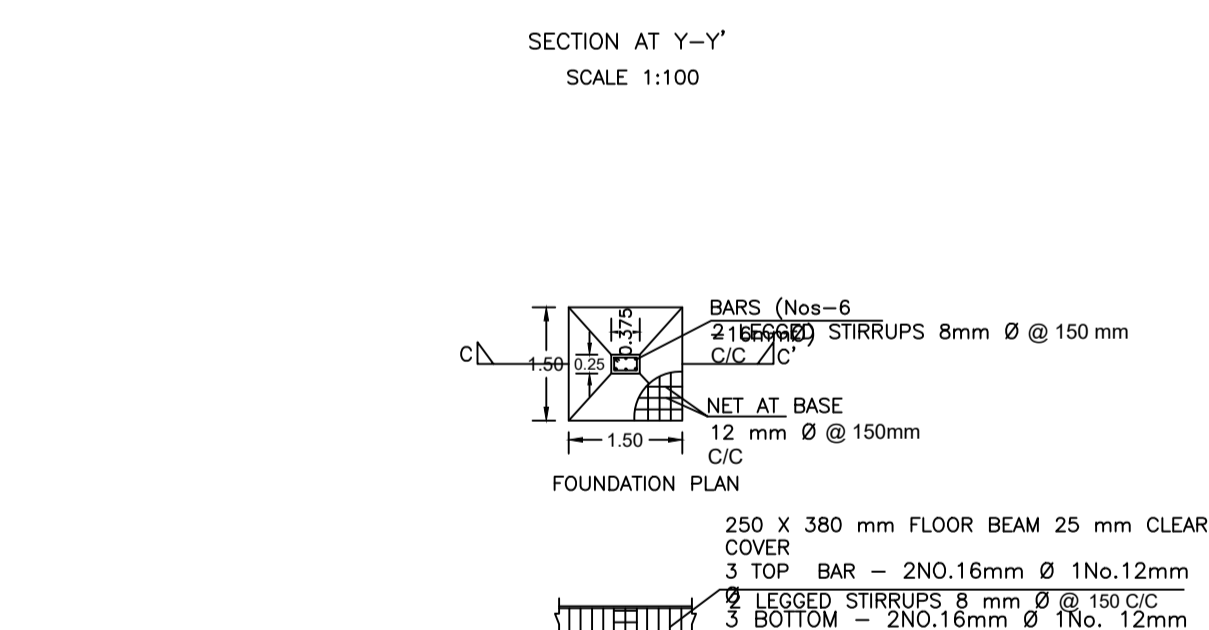
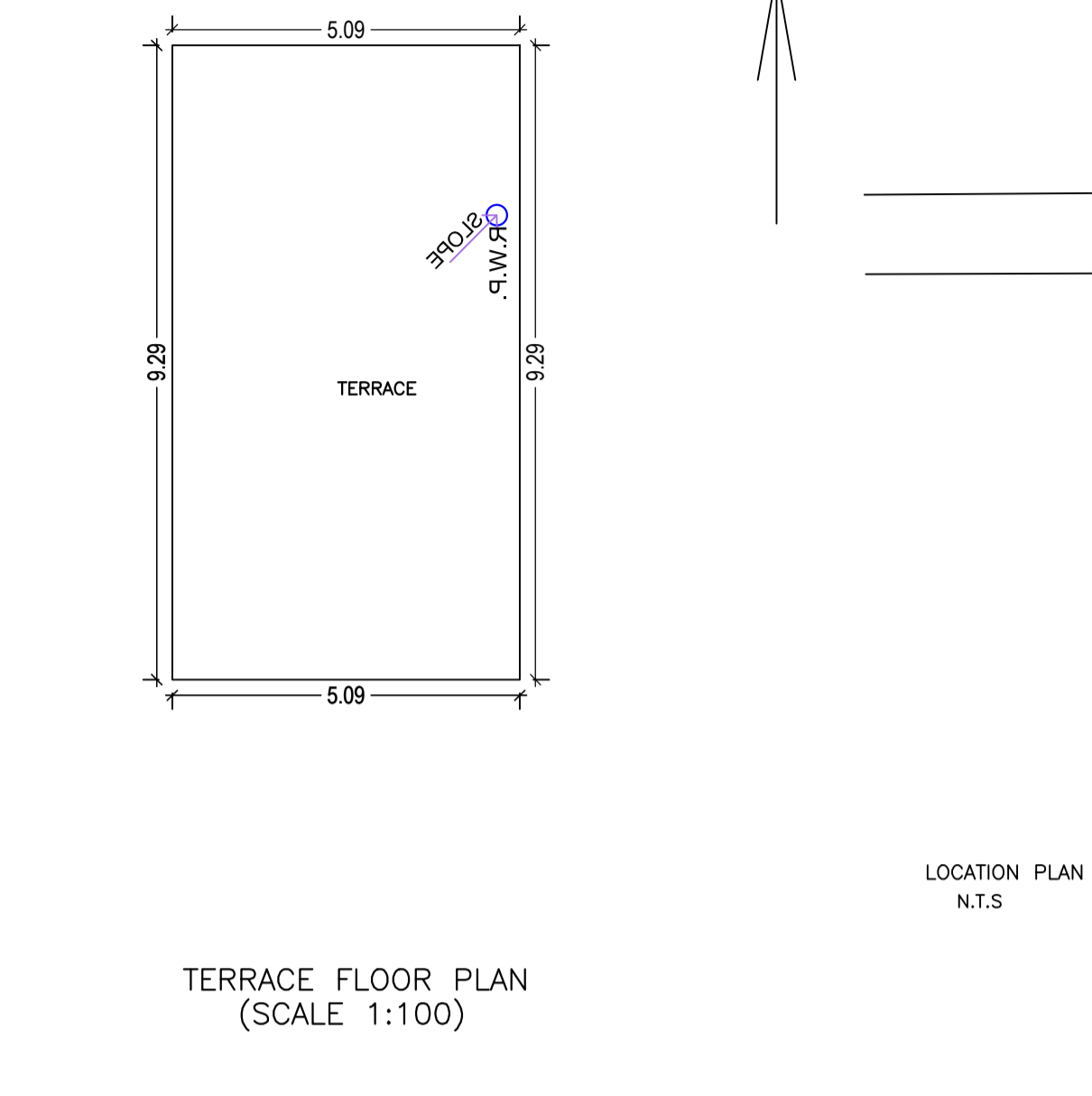
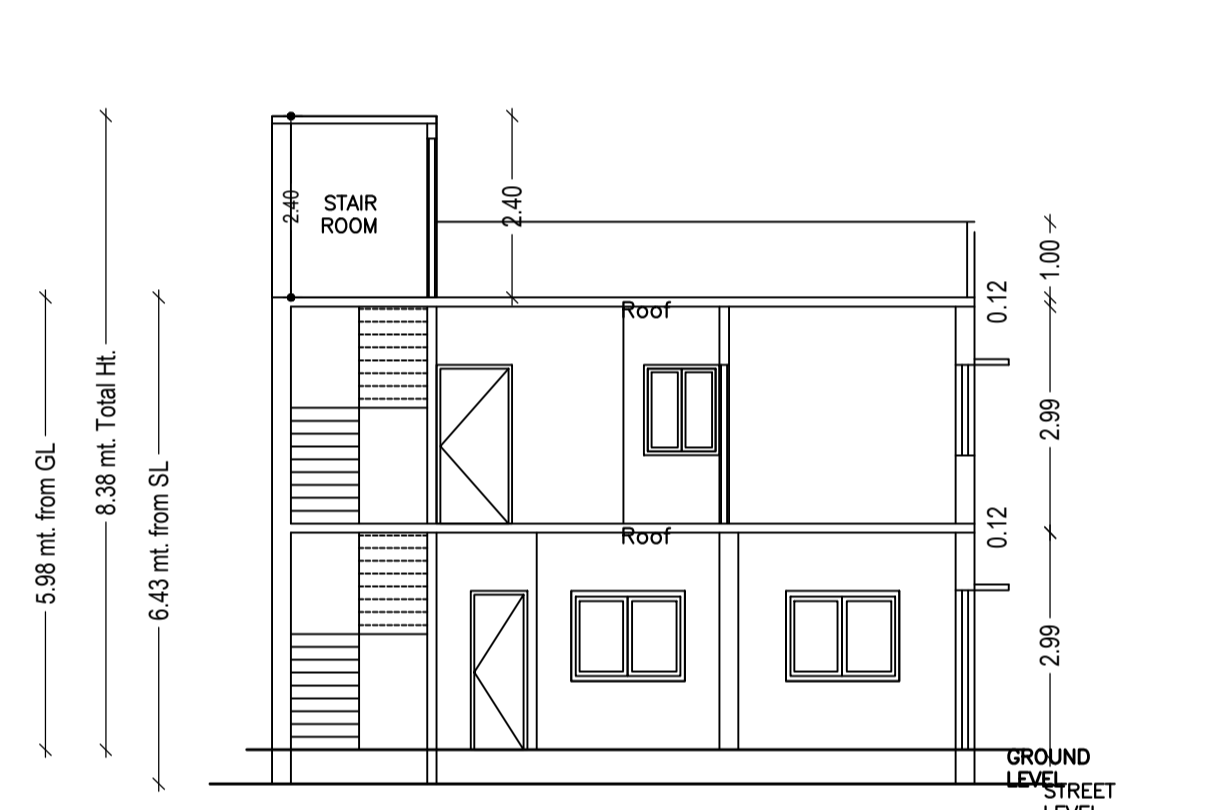
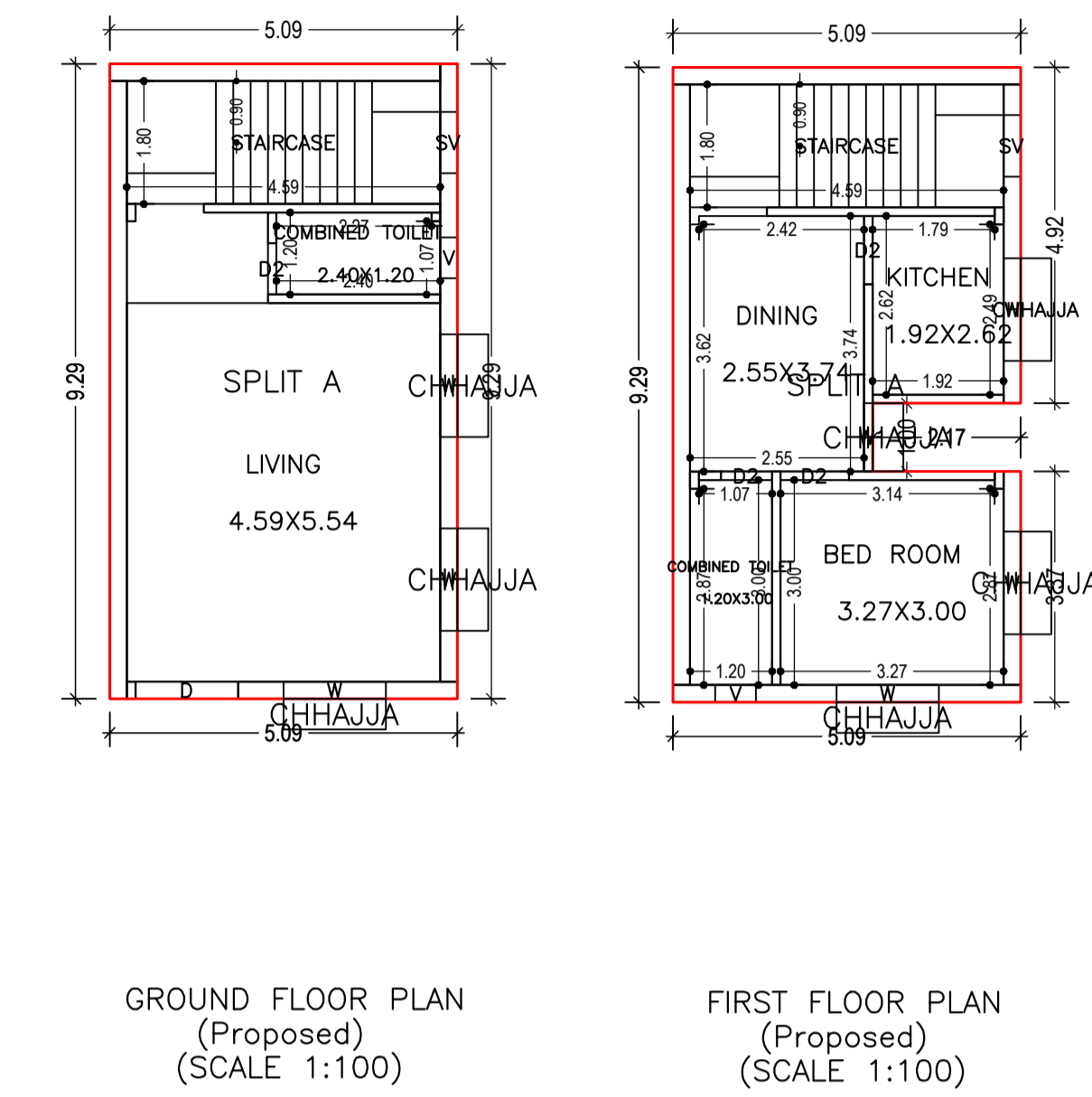
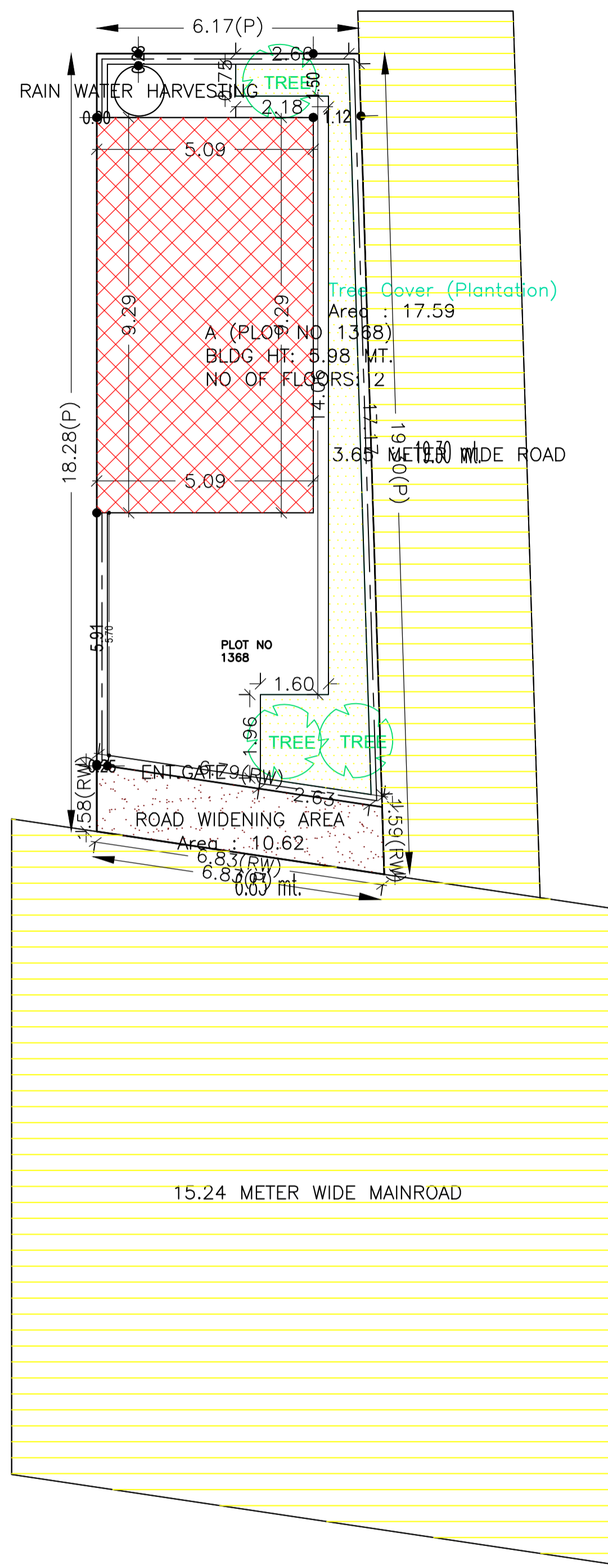

Khata No.	Plot No.	Area
95	1368	3 DIS

AREA STATEMENT		VERSION NO. : 1.0.64
MEDININAGAR MUNICIPAL CORPORATION		VERSION DATE: 16/10/2020
PROJECT DETAIL:		
Region: JHARKHAND URBAN LOCAL BODIES	Plot Use: Residential	
District: PALAMU	Plot SubUse: Bungalow/ Dwelling / Non Apartment	
Authority: MEDININAGAR MUNICIPAL CORPORATION	PlotNearbyReligiousStructure: NA	
Inward No: MNNP/BP/0245/W33/2022	Plot/Plot No: 1368	
Application Type: General Proposal	North: Plot No. - 1368	
Project Type: Building Permission	South: Road Width - 3.65	
Nature of Development: New	East: Plot No. - 1368	
Location of Development Area: Old Area	West: Road Width - 15.24	
AREA DETAILS:		SQ. MT.
AREA OF PLOT (Minimum)	(A)	121.20
Deduction for NetPlot Area		
Road Widening Area		10.62
Total		10.62
NET AREA OF PLOT(Gross Plot Area - Deduction from Gross Plot area)	(A-Deductions)	110.58
Deduction for Balance Plot Area(from Gross Plot Area)		
Road Widening Area		10.62
Common Plot		17.59
Total		28.22
BALANCE AREA OF PLOT(Net Plot Area - Recreational/Amenity space)	(A-Deductions)	92.98
PLOT AREA FOR COVERAGE(Net Plot Area)	(A-Deductions)	110.58
Plot Area for FAR (Net Plot Area + RoadWidening Area)	(A-Deductions)	110.58
COVERAGE CHECK		
Permissible Coverage area (70.00 %)		77.41
Proposed Coverage Area (42.78 %)		47.31
Total Prop. Coverage Area (42.78 %)		47.31
Balance coverage area (27.22 %)		30.10
FAR CHECK		
Perm. FAR Area (2.50)		276.45
Total Perm. FAR area		276.45
Residential FAR		92.45
Proposed FAR Area		92.45
Total Proposed FAR Area		92.45
Consumed FAR (Factor)		0.84
Balance FAR Area		184.00
BUILT UP AREA CHECK		
Total Proposed BuiltUp Area		92.45
ARCHITECT (Regd)		MD MOHSIN AKHATAR
ENGINEER (Regd)		
SUPERVISOR (Regd)		IRSAD SHAH
OWNER (Regd)		
DEVELOPMENT AUTHORITY		LOCAL BODY

COLOR INDEX	
PLOT BOUNDARY	Black
ABUTTING ROAD	Green
PROPOSED CONSTRUCTION	Red
COMMON PLOT	Yellow
ROAD WIDENING AREA	Blue
EXISTING (To be retained)	Light Blue
EXISTING (To be demolished)	Light Yellow

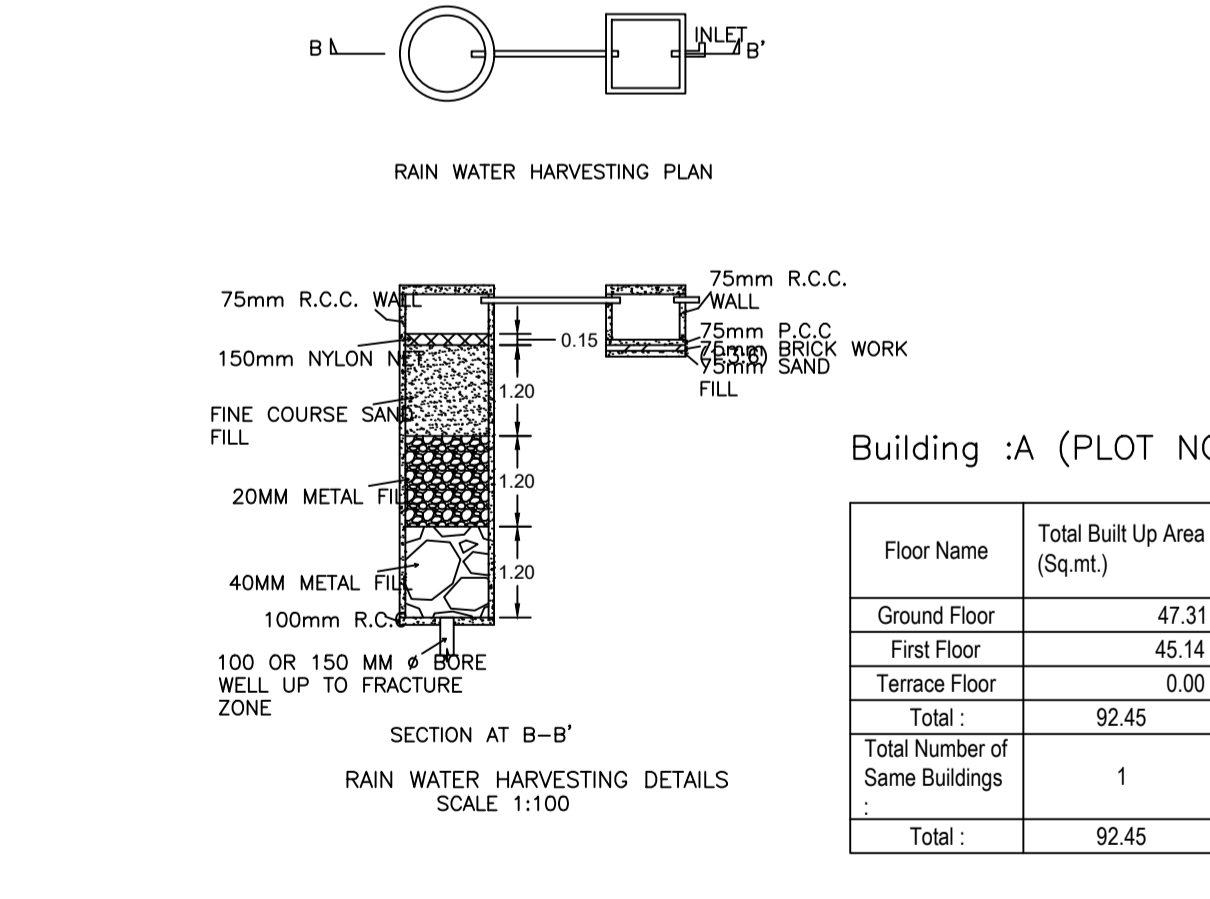
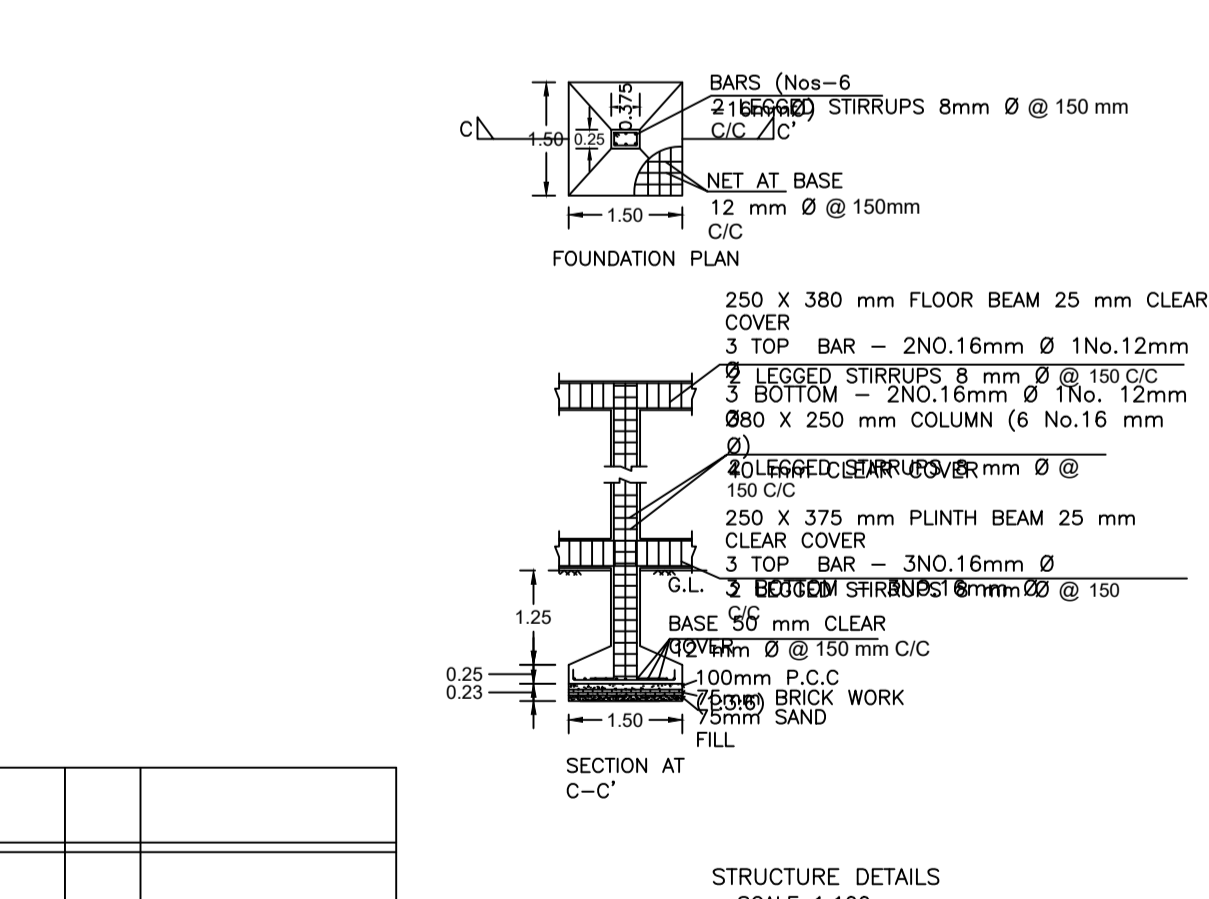
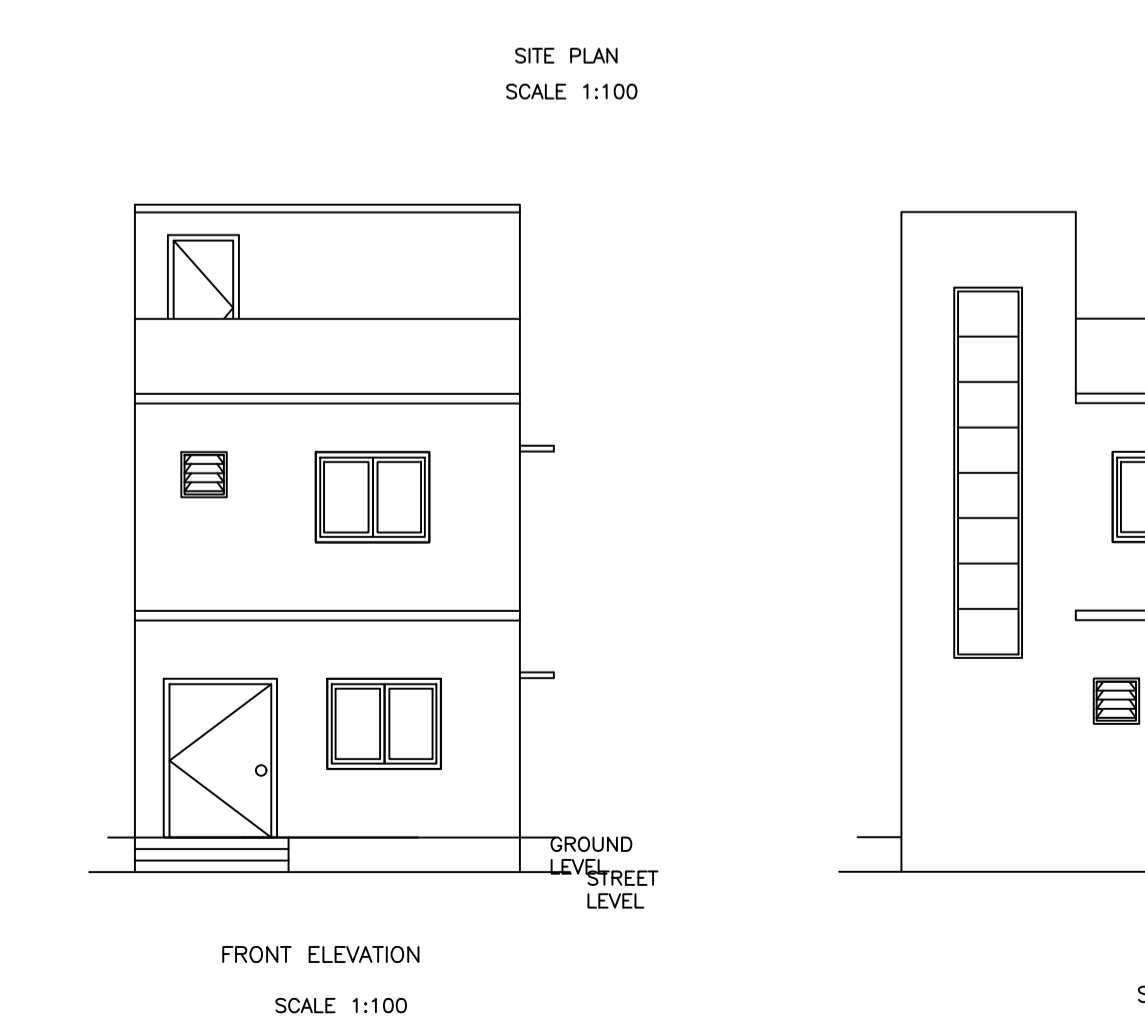

FAR & Tenement Details (Table 4c-1)						
Building	No. of Same Bldg	Total Built Up Area (Sq.mt.)	Proposed FAR Area (Sq.mt.)	Total FAR Area (Sq.mt.)	Total Consumed Additional FAR Area (Sq.mt.)	Tnmt (No.)
A (PLOT NO 1368)	1	92.45	92.45	92.45	92.45	01
Grand Total :	1	92.45	92.45	92.45	92.45	01

Building : A (PLOT NO 1368)						
Floor Name	Total Built Up Area (Sq.mt.)	Proposed FAR Area (Sq.mt.)	Total FAR Area (Sq.mt.)	Total Consumed Additional FAR Area (Sq.mt.)	Tnmt (No.)	
Ground Floor	47.31	47.31	47.31	47.31	01	
First Floor	45.14	45.14	45.14	45.14	00	
Terrace Floor	0.00	0.00	0.00	0.00	00	
Total :	92.45	92.45	92.45	92.45	01	
Total Number of Same Buildings	1					
Total :	92.45	92.45	92.45	92.45	01	

Buildingwise Floor FAR Details				
Floor Name	Building Name A (PLOT NO 1368)		Total	
	Proposed Built Up Area (Sq.mt.)	Proposed FAR Area (Sq.mt.)	Total Proposed Built Up Area (Sq.mt.)	Total FAR Area (Sq.mt.)
Ground Floor	47.31	47.31	47.31	47.31
First Floor	45.14	45.14	45.14	45.14
Terrace Floor	0.00	0.00	0.00	0.00
Total :	92.45	92.45	92.45	92.45

Building USE/SUBUSE Details			
Building Name	Building Use	Building SubUse	Building Structure
A (PLOT NO 1368)	Residential	Bungalow/ Dwelling / Non Apartment	Non-Highrise

UnitBUA Table for Building :A (PLOT NO 1368)						
FLOOR	Name	UnitBUA Type	UnitBUA Area	Carpet Area	No. of Rooms	No. of Tenement
GROUND FLOOR PLAN	SPLIT A	FLAT	92.45	76.55	2	1
FIRST FLOOR PLAN	SPLIT A	FLAT	0.00	0.00	4	0
Total:	-	-	92.45	76.55	6	1

SCHEDULE OF DOOR:				
BUILDING NAME	NAME	LENGTH	HEIGHT	NOS
A (PLOT NO 1368)	D2	0.75	2.10	02
A (PLOT NO 1368)	D2	1.00	2.10	02
A (PLOT NO 1368)	D	1.50	2.10	01

SCHEDULE OF WINDOW/VENTILATION:				
BUILDING NAME	NAME	LENGTH	HEIGHT	NOS
A (PLOT NO 1368)	V	0.60	0.60	02
A (PLOT NO 1368)	SV	0.90	3.00	02
A (PLOT NO 1368)	W1	1.00	1.20	01
A (PLOT NO 1368)	W	1.50	1.20	06

LTP NAME AND SIGNATURE	STRUCTURAL ENG'S NAME AND SIGNATURE	BUILDER NAME AND SIGNATURE	DIGITAL SIGNATURE
MD MOHSIN AKHATAR MNNP/ENG/0001/2022			