

FAR & Tenement Details (Table 4c-1)

Building	No. of Same Bldg	Total Built Up Area (Sq.mt.)	Proposed FAR Area (Sq.mt.) Resi.	Total FAR Area (Sq.mt.)	Total Consumed Additional FAR Area (Sq.mt.)	Tnmt (No.)
A (BUILDING)	1	98.01	98.01	98.01	98.01	01
Grand Total :	1	98.01	98.01	98.01	98.01	01

Proposal Basic Information

Proposal File No.	MNNP/BP/0244/W25/2022
Owner Name	REKHA AGRAWAL
Khata No	0
Plot No	469*
Village Name	Kundh
Use	Residential
SubUse	Bungalow/ Dwelling / Non Apartment

AREA STATEMENT

AREA DETAILS:	SQ.MT.
AREA OF PLOT (Minimum)	90.80
Deduction for NetPlot Area	
Surrender Free of Cost	4.31
Total	4.31
NET AREA OF PLOT (Gross Plot Area - Deduction from Gross Plot area)	86.49
Deduction for Balance Plot Area (from Gross Plot Area)	
Surrender Free of Cost	4.31
Common Plot	7.80
Total	12.11
BALANCE AREA OF PLOT (Net Plot Area - Recreational/Amenity space)	78.69
PLOT AREA FOR COVERAGE (Net Plot Area)	86.49
Plot Area for FAR (Net Plot Area + Road Widening Area)	90.80
COVERAGE CHECK	
Permissible Coverage area (70.00 %)	60.54
Proposed Coverage Area (56.56 %)	48.92
Total Prop. Coverage Area (56.56 %)	48.92
Balance coverage area (13.44 %)	11.62
FAR CHECK	
Perm. FAR Area (1.20)	108.96
Total Perm. FAR area	108.96
Residential FAR	98.01
Proposed FAR Area	98.01
Total Proposed FAR Area	98.01
Consumed FAR (Factor)	1.08
Balance FAR Area	10.95
BUILT UP AREA CHECK	
Total Proposed BuiltUp Area	98.01
ARCHITECT (Regd)	RANJIT KUMAR
ENGINEER (Regd)	
SUPERVISOR (Regd)	
OWNER (Regd)	REKHA AGRAWAL
DEVELOPMENT AUTHORITY	LOCAL BODY

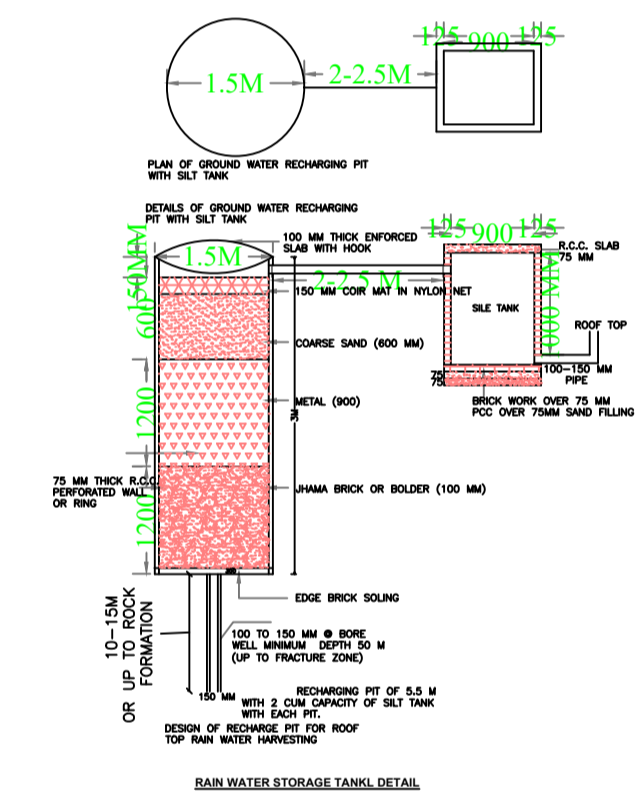
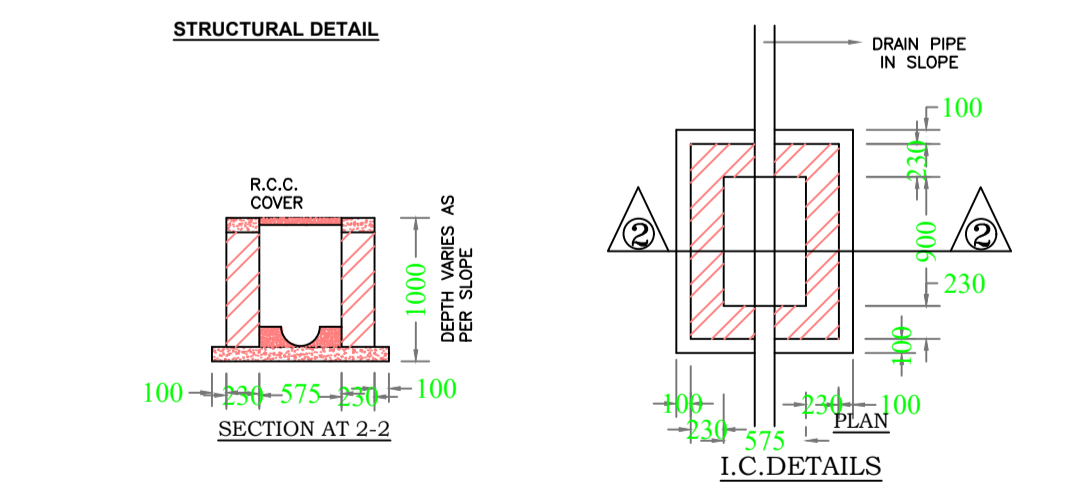
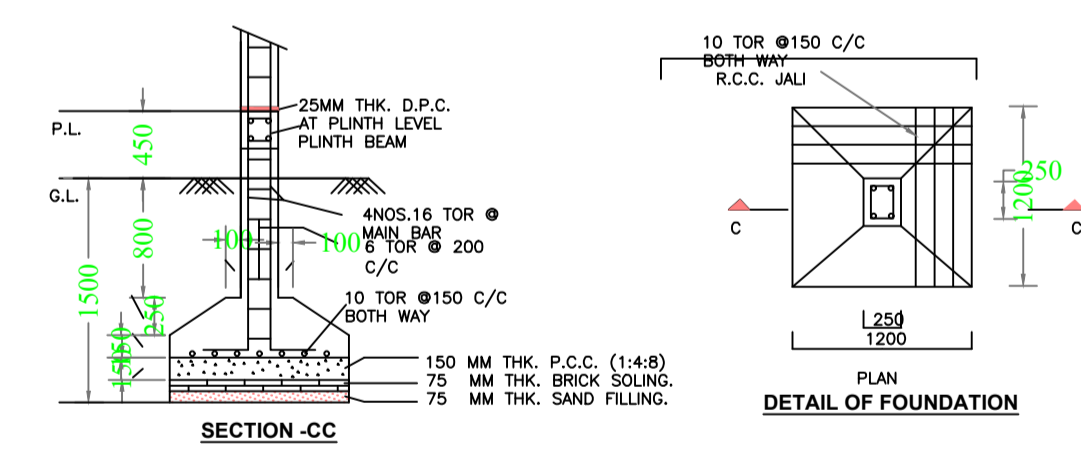
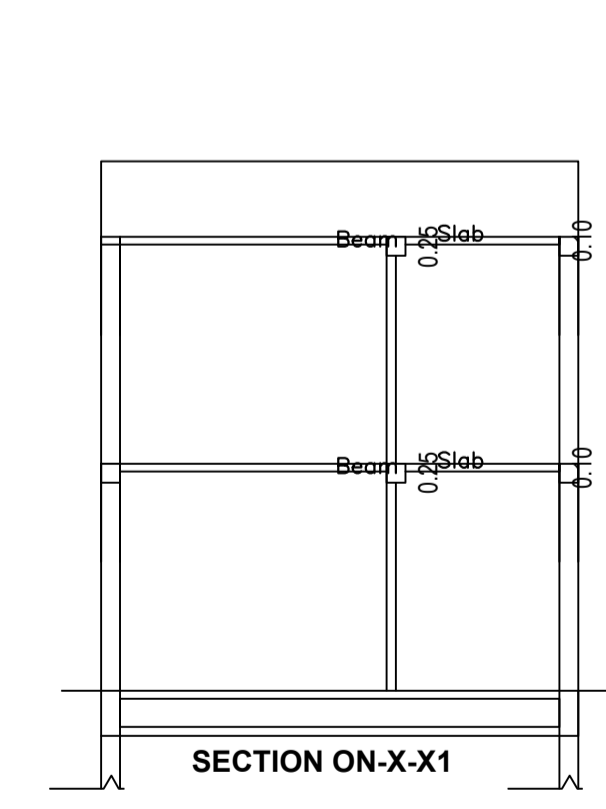
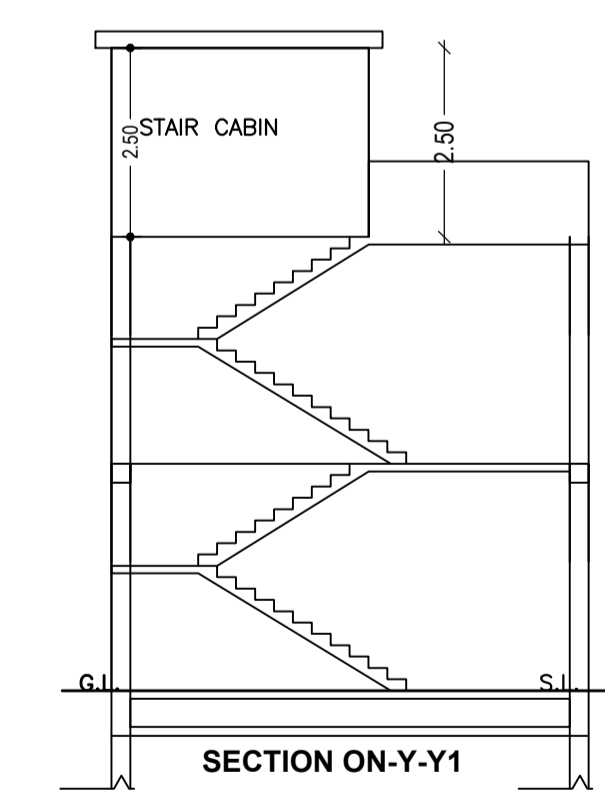
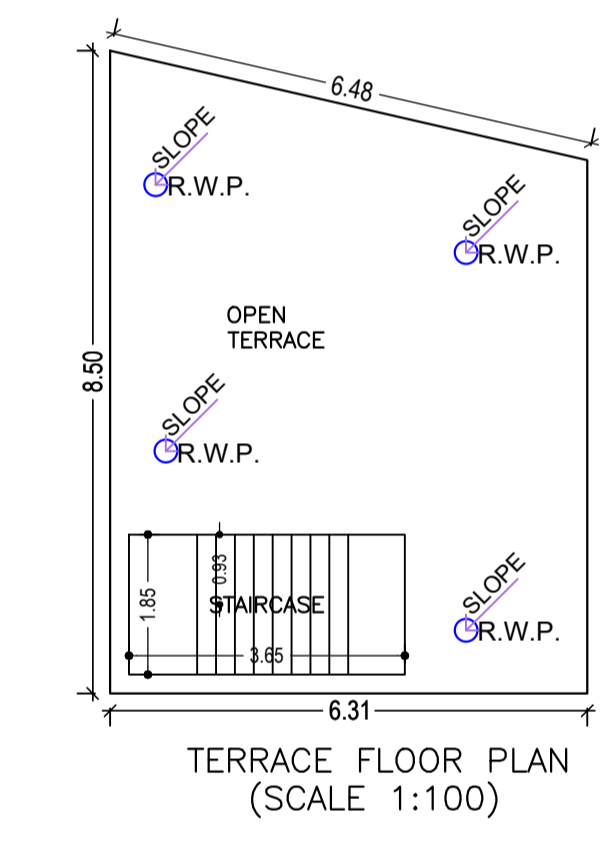
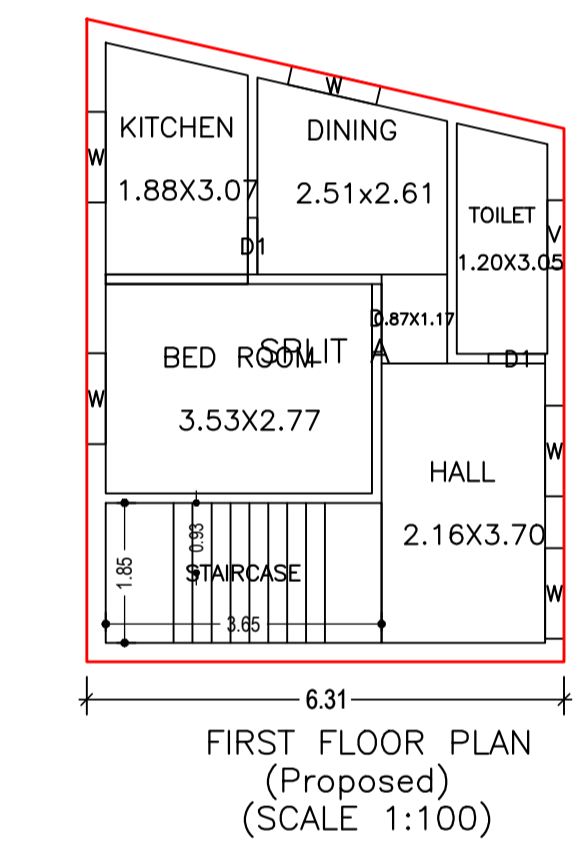
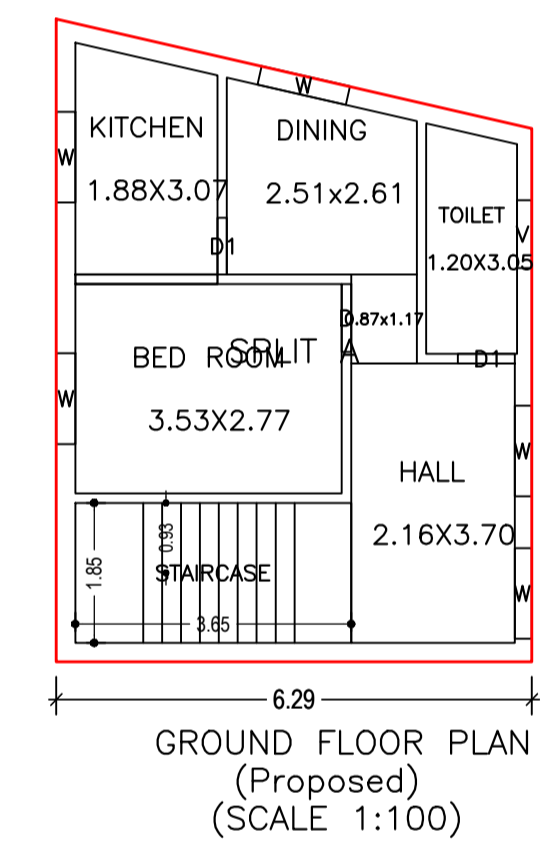

COLOR INDEX

PLOT BOUNDARY	Black
ABUTTING ROAD	Green
PROPOSED CONSTRUCTION	Red
COMMON PLOT	Yellow
ROAD WIDENING AREA	Blue
EXISTING (To be retained)	Orange
EXISTING (To be demolished)	White

Building :A (BUILDING)

Floor Name	Total Built Up Area (Sq.mt.)	Proposed FAR Area (Sq.mt.) Resi.	Total FAR Area (Sq.mt.)	Total Consumed Additional FAR Area (Sq.mt.)	Tnmt (No.)
Ground Floor	48.92	48.92	48.92	48.92	01
First Floor	49.09	49.09	49.09	49.09	00
Terrace Floor	0.00	0.00	0.00	0.00	00
Total :	98.01	98.01	98.01	98.01	01
Total Number of Same Buildings	1				
Total :	98.01	98.01	98.01	98.01	01

SCHEDULE OF DOOR:

BUILDING NAME	NAME	LENGTH	HEIGHT	NOS
A (BUILDING)	D1	0.75	2.10	04
A (BUILDING)	D	0.90	2.10	02

SCHEDULE OF WINDOW/VENTILATION:

BUILDING NAME	NAME	LENGTH	HEIGHT	NOS
A (BUILDING)	V	0.90	0.60	02
A (BUILDING)	W	1.20	1.20	10

UnitBUA Table for Building :A (BUILDING)

FLOOR	Name	UnitBUA Type	UnitBUA Area	Carpet Area	No. of Rooms	No. of Tenement
GROUND FLOOR PLAN	SPLIT A	FLAT	81.62	81.15	5	1
FIRST FLOOR PLAN	SPLIT A	FLAT	0.00	0.00	5	0
Total:	-	-	81.62	81.15	10	1

LTP NAME AND SIGNATURE	STRUCTURAL ENG'S NAME AND SIGNATURE	BUILDER NAME AND SIGNATURE	DIGITAL SIGNATURE
RANJIT KUMAR MNNP/ENG/0001/2016			