

Proposal Basic Information

Proposal File No.	MNNP/BI/0314/W02/2022
Owner Name	Maya Devi
Khata No	00
Plot No	276
Village Name	Kundh
Use	Residential
SubUse	Bungalow/ Dwelling / Non Apartment

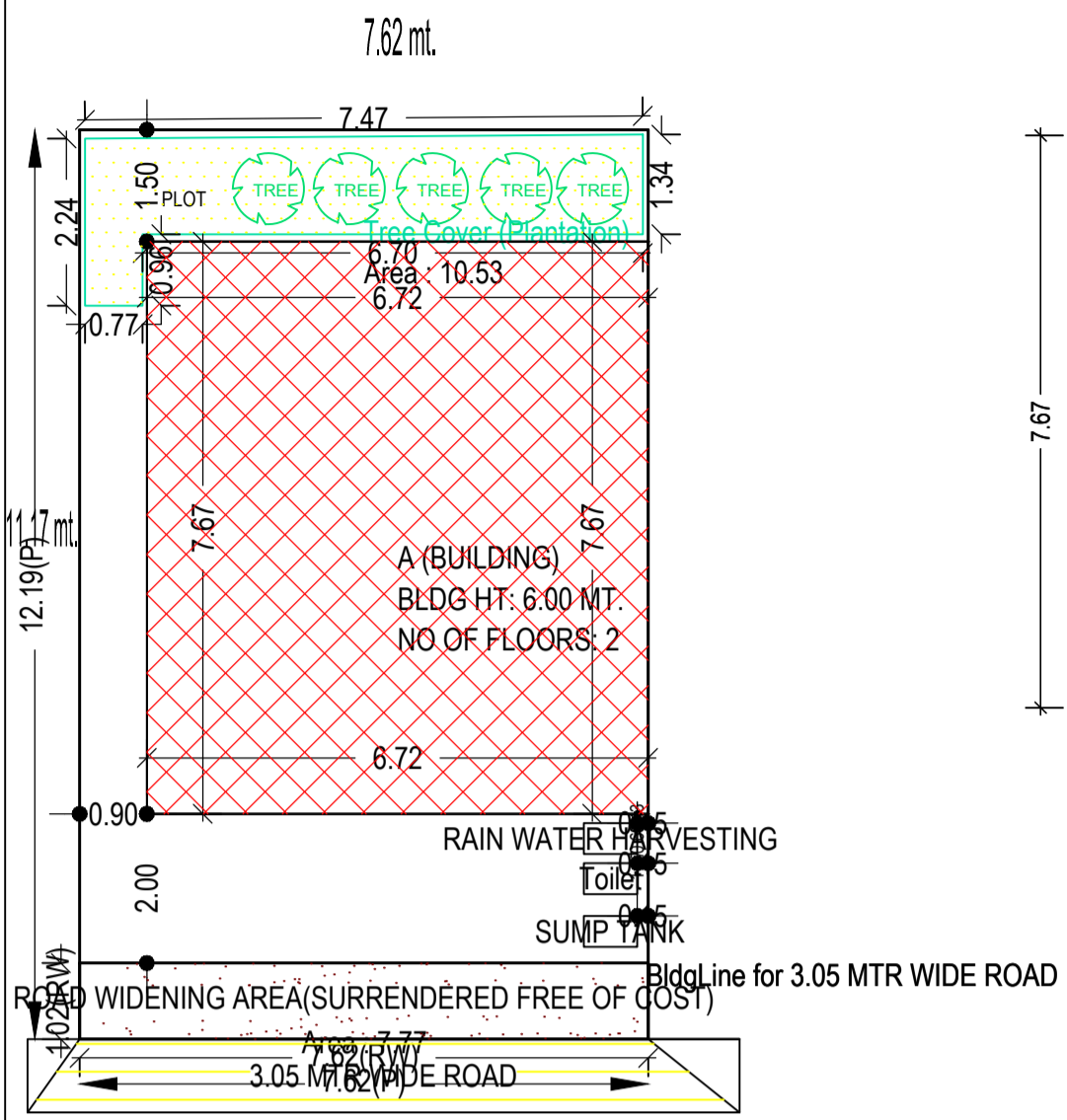

SITE PLAN

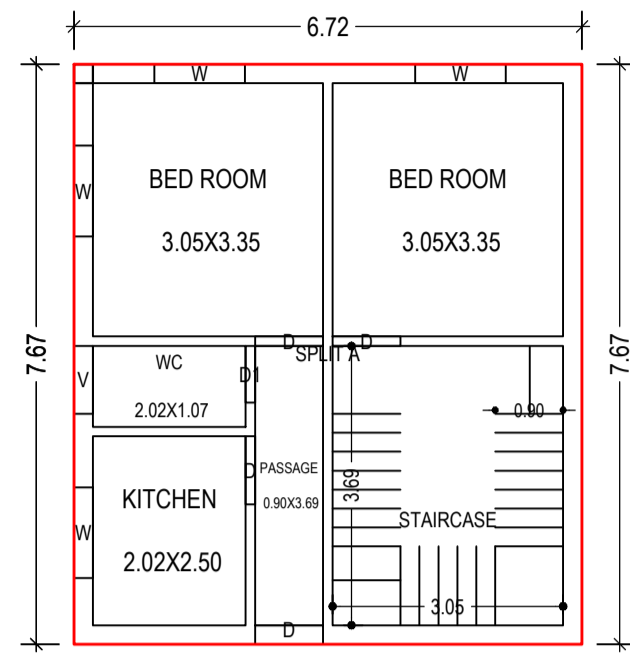

GROUND FLOOR PLAN (Proposed) (SCALE 1:100)

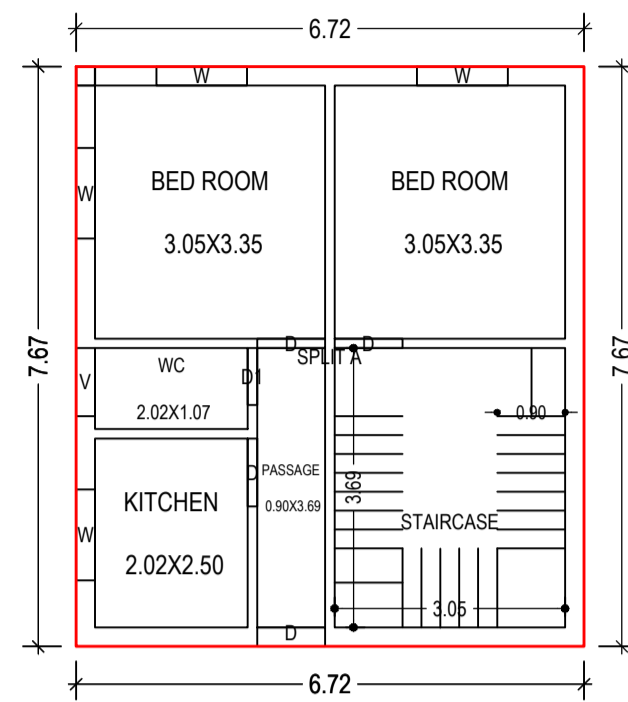

FIRST FLOOR PLAN (Proposed) (SCALE 1:100)

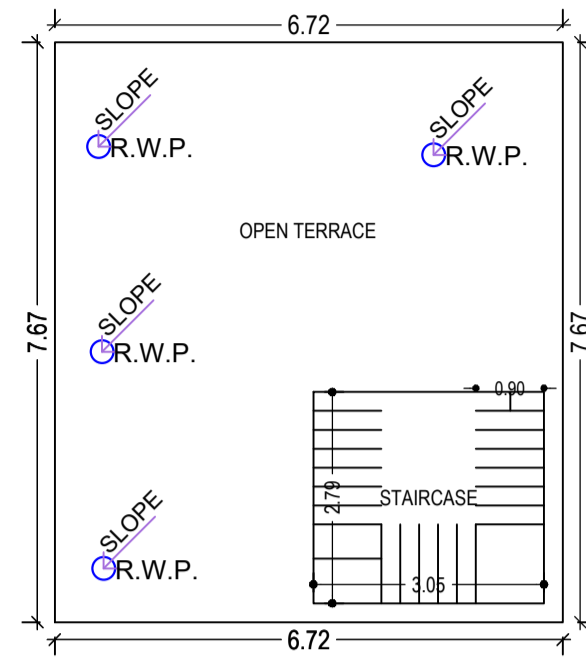

TERRACE FLOOR PLAN (SCALE 1:100)

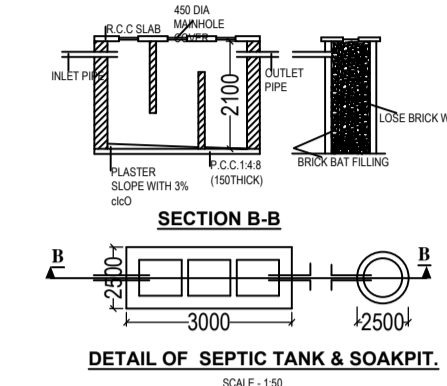

DETAIL OF SEPTIC TANK & SOAKPIT (SCALE: 1:50)

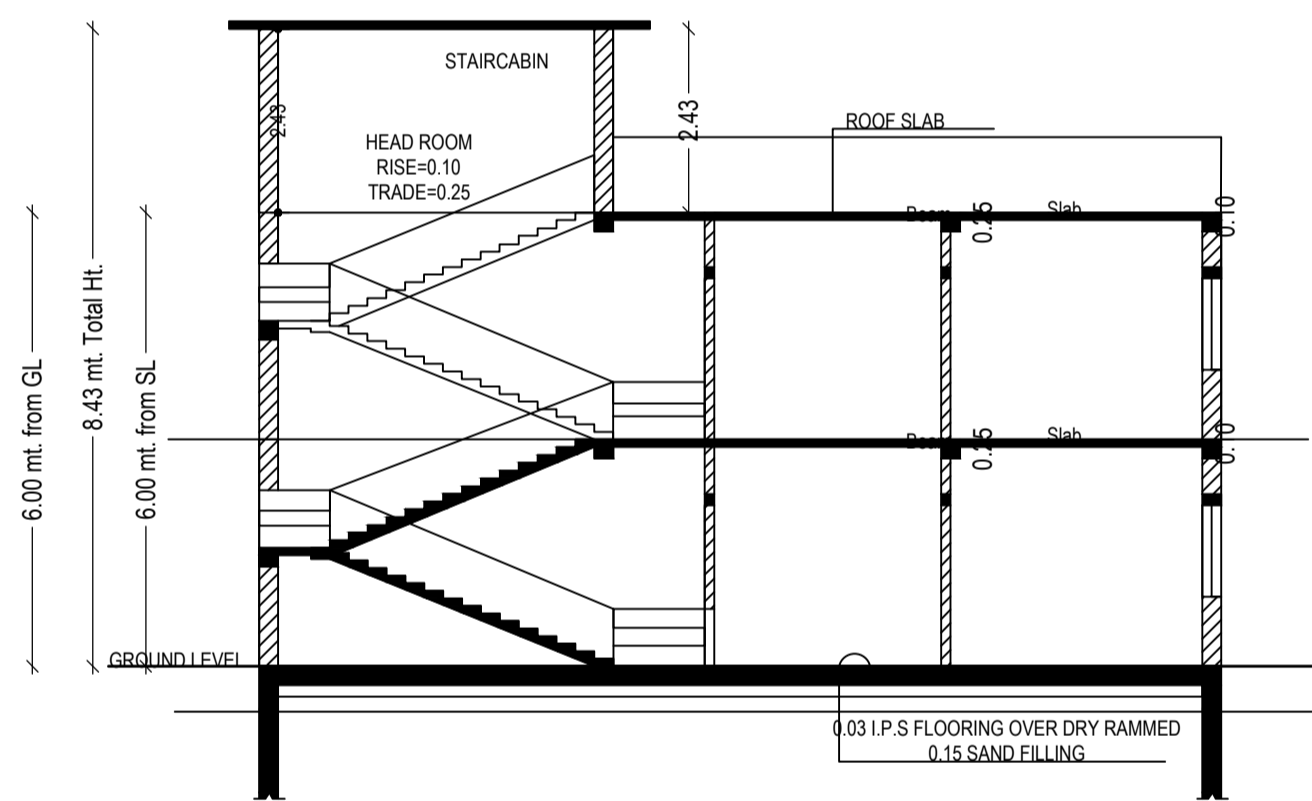

SECTION ON-XX

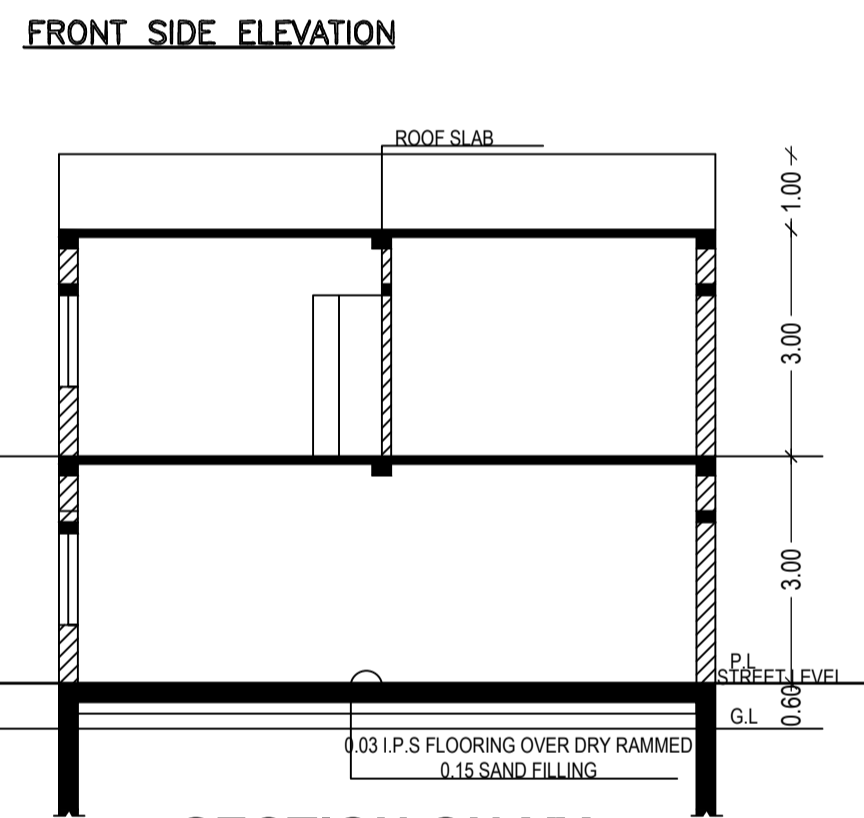

SECTION ON-YY

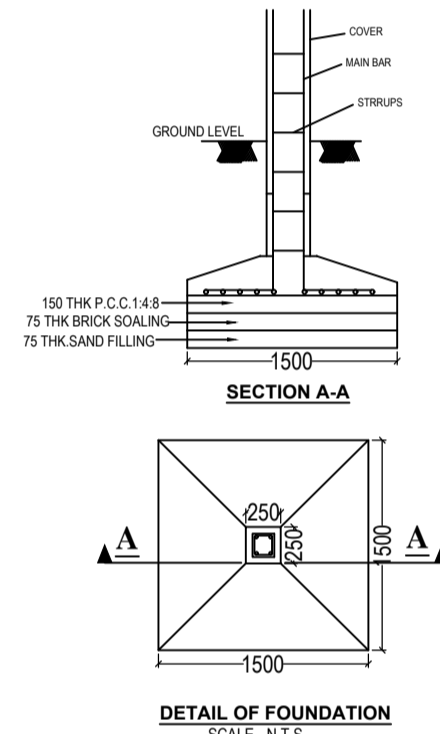

DETAIL OF FOUNDATION (SCALE: 1:1.5)

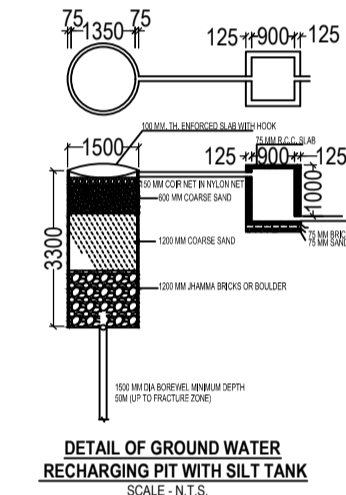

DETAIL OF GROUND WATER RECHARGING PIT WITH SILT TANK (SCALE: 1:1.5)

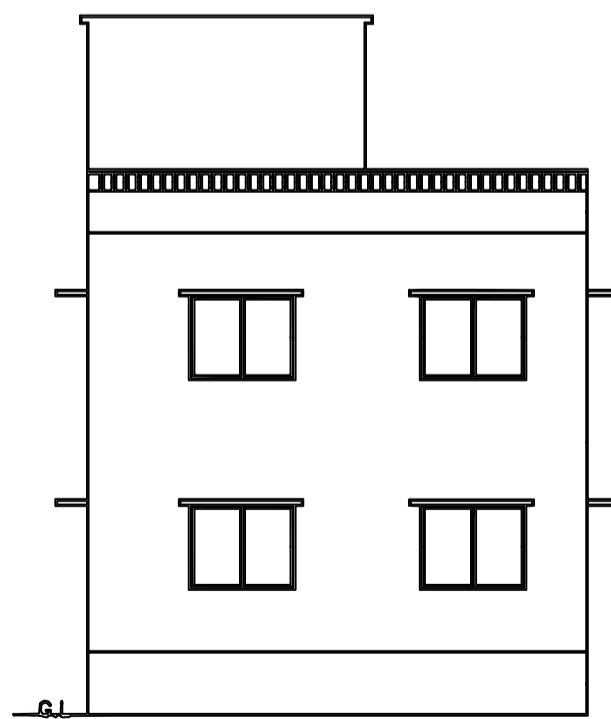
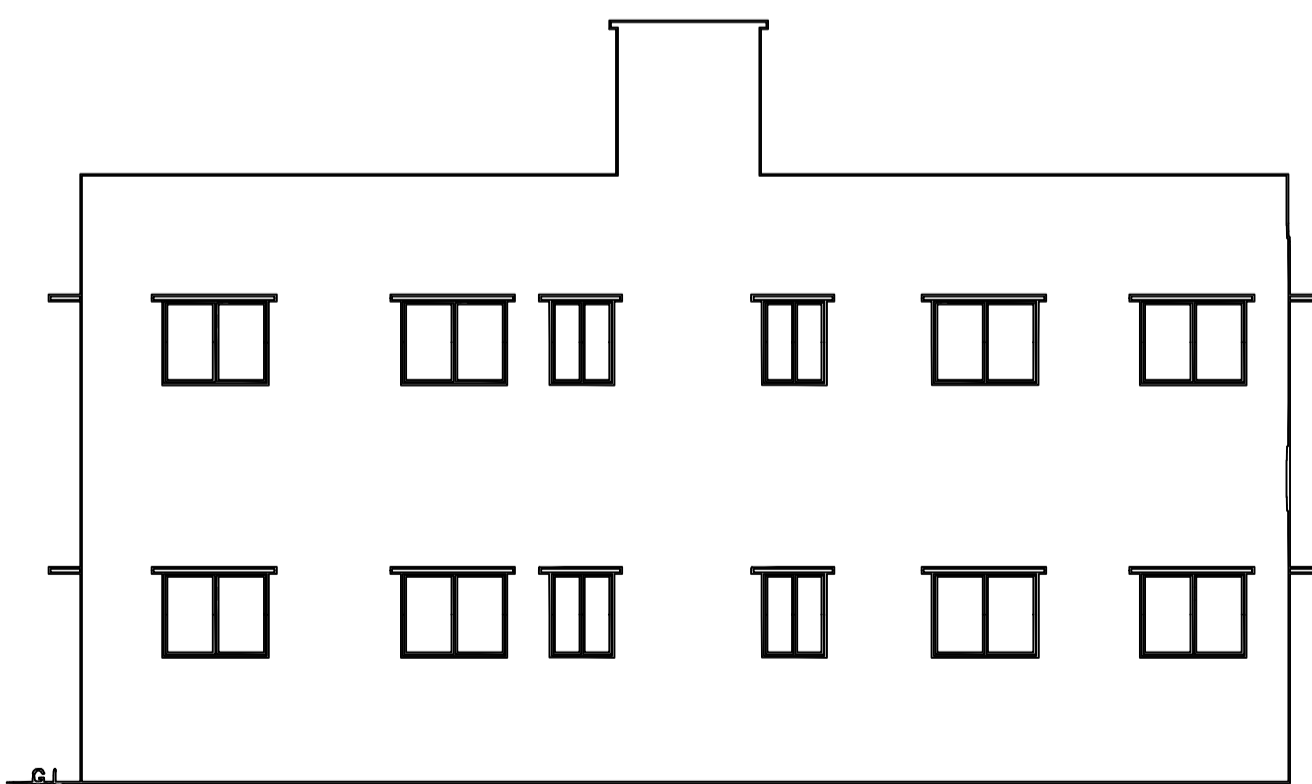

Building :A (BUILDING)

Floor Name	Total Built Up Area (Sq. mt.)	Proposed FAR Area (Sq. mt.) Resi.	Total FAR Area (Sq. mt.)	Total Consumed Additional FAR Area (Sq. mt.)	Tnmt (No.)
Ground Floor	51.54	51.54	51.54	51.54	01
First Floor	51.54	51.54	51.54	51.54	00
Terrace Floor	0.00	0.00	0.00	0.00	00
Total :	103.08	103.08	103.08	103.08	01
Total Number of Same Buildings :	1				
Total :	103.08	103.08	103.08	103.08	01

SCHEDULE OF DOOR:

BUILDING NAME	NAME	LENGTH	HEIGHT	NOS
A (BUILDING)	D1	0.75	2.10	02
A (BUILDING)	D	0.90	2.10	08

SCHEDULE OF WINDOW/VENTILATION:

BUILDING NAME	NAME	LENGTH	HEIGHT	NOS
A (BUILDING)	V	0.90	0.60	02
A (BUILDING)	W	1.20	1.20	08

UnitBUA Table for Building :A (BUILDING)

FLOOR	Name	UnitBUA Type	UnitBUA Area	Carpet Area	No. of Rooms	No. of Tenement
GROUND FLOOR PLAN	SPLIT A	FLAT	77.05	76.92	5	1
FIRST FLOOR PLAN	SPLIT A	FLAT	0.00	0.00	5	0
Total:	-	-	77.05	76.92	10	1

AREA STATEMENT		VERSION NO. : 1.0.65
MEDININAGAR MUNICIPAL CORPORATION		VERSION DATE: 16/10/2020
PROJECT DETAIL:		
Region: JHARKHAND URBAN LOCAL BODIES	Plot Use: Residential	
District: PALAMU	Plot SubUse: Bungalow/ Dwelling / Non Apartment	
Authority: MEDININAGAR MUNICIPAL CORPORATION	PlotNearby/Religious/Structure: NA	
Inward No: MNNP/BI/0314/W02/2022	Plot/SubPlot No: 276	
Application Type: General Proposal	North: -	
Project Type: Building Permission	South: -	
Nature of Development: New	East: -	
Location of Development Area: Old Area	West: -	
AREA DETAILS:		
AREA OF PLOT (Minimum)	(A)	SQ.MT. 82.45
Deduction for NetPlot Area	Surrender Free of Cost	7.77
Total		7.77
NET AREA OF PLOT(Gross Plot Area - Deduction from Gross Plot area)	(A-Deductions)	84.68
Deduction for Balance Plot Area(from Gross Plot Area)	Surrender Free of Cost	7.77
Common Plot		10.53
Total		18.30
BALANCE AREA OF PLOT(Net Plot Area - Recreational/Amenity space)	(A-Deductions)	74.15
PLOT AREA FOR COVERAGE(Net Plot Area)	(A-Deductions)	84.68
Plot Area for FAR (Net Plot Area + Road/Widening Area)	(A-Deductions)	92.45
COVERAGE CHECK		
Permissible Coverage area ( 70.00 % )		59.28
Proposed Coverage Area ( 60.87 % )		51.54
Total Prpg. Coverage Area ( 60.87 % )		51.54
Balance coverage area ( 9.14 % )		7.74
FAR CHECK		
Perm. FAR Area ( 1.200 )		110.94
Total Perm. FAR area		110.94
Residential FAR area		103.08
Proposed FAR Area		103.08
Total Proposed FAR Area		103.08
Consumed FAR (Factor)		1.11
Balance FAR Area		7.86
BUILT UP AREA CHECK		
Total Proposed BuiltUp Area		103.08
ARCHITECT (Regd)	PANKAJ KUMAR SINGH	
ENGINEER (Regd)		
SUPERVISOR (Regd)		
OWNER (Regd)	Maya Devi	
DEVELOPMENT AUTHORITY		LOCAL BODY

COLOR INDEX	
PLOT BOUNDARY	Black
ABUTTING ROAD	Red
PROPOSED CONSTRUCTION	Green
COMMON PLOT	Yellow
ROAD WIDENING AREA	Blue
EXISTING (To be retained)	Orange
EXISTING (To be demolished)	Purple

Buildingwise Floor FAR Details

Floor Name	Building Name A (BUILDING)		Total	
	Proposed Built Up Area (Sq. mt.)	Proposed FAR Area (Sq. mt.)	Total Proposed Built Up Area (Sq. mt.)	Total FAR Area (Sq. mt.)
Ground Floor	51.54	51.54	51.54	51.54
First Floor	51.54	51.54	51.54	51.54
Terrace Floor	0.00	0.00	0.00	0.00
Total :	103.08	103.08	103.08	103.08

Building USE/SUBUSE Details

Building Name	Building Use	Building SubUse	Building Structure
A (BUILDING)	Residential	Bungalow/ Dwelling / Non Apartment	Non-Highrise

FAR & Tenement Details (Table 4c-1)

Building	No. of Same Bldg	Total Built Up Area (Sq. mt.)	Proposed FAR Area (Sq. mt.) Resi.	Total FAR Area (Sq. mt.)	Total Consumed Additional FAR Area (Sq. mt.)	Tnmt (No.)
A (BUILDING)	1	103.08	103.08	103.08	103.08	01
Grand Total :	1	103.08	103.08	103.08	103.08	01

LTP NAME AND SIGNATURE	STRUCTURAL ENG'S NAME AND SIGNATURE	BUILDER NAME AND SIGNATURE	DIGITAL SIGNATURE
PANKAJ KUMAR SINGH MNNP/ENG/0006/2019			