

SITE PLAN

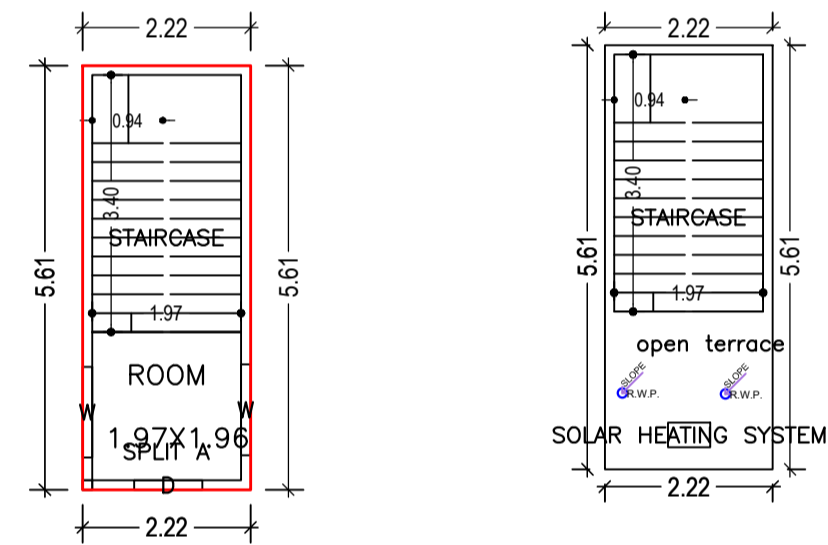

GROUND FLOOR PLAN (Proposed) (SCALE 1:100)

TERRACE FLOOR PLAN (SCALE 1:100)

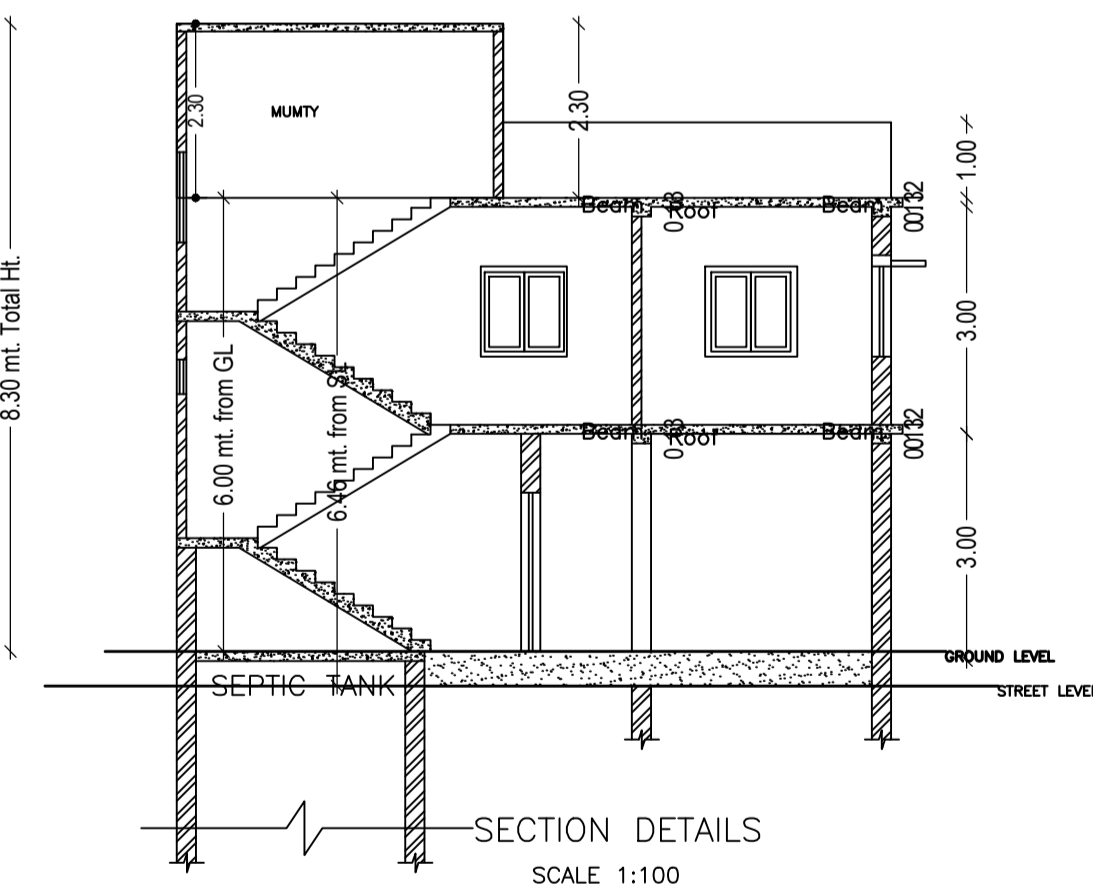

SECTION DETAILS (SCALE 1:100)

FIRST FLOOR PLAN (Proposed) (SCALE 1:100)

Building :A (BUILDING)

Floor Name	Total Built Up Area (Sq.mt.)	Proposed FAR Area (Sq.mt.) Resi.	Total FAR Area (Sq.mt.)	Total Consumed Additional FAR Area (Sq.mt.)	Tnmt (No.)
Ground Floor	12.45	12.45	12.45	12.45	01
First Floor	12.45	12.45	12.45	12.45	00
Terrace Floor	0.00	0.00	0.00	0.00	00
<b>Total :</b>	<b>24.90</b>	<b>24.90</b>	<b>24.90</b>	<b>24.90</b>	<b>01</b>
Total Number of Same Buildings	1				
<b>Total :</b>	<b>24.90</b>	<b>24.90</b>	<b>24.90</b>	<b>24.90</b>	<b>01</b>

SCHEDULE OF DOOR:

BUILDING NAME	NAME	LENGTH	HEIGHT	NOS
A (BUILDING)	D	0.90	2.10	02

SCHEDULE OF WINDOW/VENTILATION:

BUILDING NAME	NAME	LENGTH	HEIGHT	NOS
A (BUILDING)	W	1.20	1.20	04

UnitBUA Table for Building :A (BUILDING)

FLOOR	Name	UnitBUA Type	UnitBUA Area	Carpet Area	No. of Rooms	No. of Tenement
GROUND FLOOR PLAN	SPLIT A	FLAT	9.26	9.23	1	1
FIRST FLOOR PLAN	SPLIT A	FLAT	0.00	0.00	1	0
<b>Total:</b>	-	-	9.26	9.23	2	1

FAR & Tenement Details (Table 4c-1)

Building	No. of Same Bldg	Total Built Up Area (Sq.mt.)	Proposed FAR Area (Sq.mt.) Resi.	Total FAR Area (Sq.mt.)	Total Consumed Additional FAR Area (Sq.mt.)	Tnmt (No.)
A (BUILDING)	1	24.90	24.90	24.90	24.90	01
<b>Grand Total :</b>	<b>1</b>	<b>24.90</b>	<b>24.90</b>	<b>24.90</b>	<b>24.90</b>	<b>01</b>

Proposal Basic Information

Proposal File No.	MNNP/BP/0331/W05/2022
Owner Name	Sagiruddin Ahamad
Khata No	00
Plot No	779
Village Name	Kundh
Use	Residential
SubUse	Bungalow/ Dwelling / Non Apartment

AREA STATEMENT	VERSION NO. : 1.0.66
MEDININAGAR MUNICIPAL CORPORATION	VERSION DATE: 16/10/2020

Region: JHARKHAND URBAN LOCAL BODIES	Plot Use: Residential
District: PALAMU	Plot SubUse: Bungalow/ Dwelling / Non Apartment
Authority: MEDININAGAR MUNICIPAL CORPORATION	PlotNearby/ReligiousStructure: NA
Inward No: MNNP/BP/0331/W05/2022	Plot/SubPlot No: 779
Application Type: General Proposal	North: -
Project Type: Building Permission	South: -
Nature of Development: New	East: -
Location of Development Area: New Area	West: -

AREA DETAILS:		SQ.MT.
AREA OF PLOT (Minimum)	(A)	32.32
Deduction for NetPlot Area		
Surrender Free of Cost		3.90
Total		3.90
NET AREA OF PLOT(Gross Plot Area - Deduction from Gross Plot area)	(A-Deductions)	28.42
Deduction for Balance Plot Area(from Gross Plot Area)		
Surrender Free of Cost		3.90
Common Plot		3.87
Total		7.77

BALANCE AREA OF PLOT(Net Plot Area - Recreational/Amenity space)	(A-Deductions)	24.55
PLOT AREA FOR COVERAGE(Net Plot Area)	(A-Deductions)	28.42
Plot Area for FAR (Net Plot Area + Road/Widening Area)	(A-Deductions)	32.32

COVERAGE CHECK		
Permissible Coverage area ( 70.00 % )		19.89
Proposed Coverage Area ( 43.80 % )		12.45
Total Prop. Coverage Area ( 43.8 % )		12.45
Balance coverage area ( 26.18 % )		7.44

FAR CHECK		
Perm. FAR Area ( 1.500 )		48.48
Total Perm. FAR area		48.48
Residential FAR		24.91
Proposed FAR Area		24.91
Total Proposed FAR Area		24.91
Consumed FAR (Factor)		0.77
Balance FAR Area		23.57

BUILT UP AREA CHECK		
Total Proposed BuiltUp Area		24.90
ARCHITECT (Regd)	PANKAJ KUMAR SINGH	
ENGINEER (Regd)		
SUPERVISOR (Regd)		
OWNER (Regd)	Sagiruddin Ahamad	
DEVELOPMENT AUTHORITY	LOCAL BODY	

COLOR INDEX	
PLOT BOUNDARY	Black
ABUTTING ROAD	Green
PROPOSED CONSTRUCTION	Red
COMMON PLOT	Yellow
ROAD WIDENING AREA	Blue
EXISTING (To be retained)	Orange
EXISTING (To be demolished)	White

Buildingwise Floor FAR Details

Floor Name	Building Name A (BUILDING)		Total	
	Proposed Built Up Area (Sq.mt.)	Proposed FAR Area (Sq.mt.)	Total Proposed Built Up Area (Sq.mt.)	Total FAR Area (Sq.mt.)
Ground Floor	12.45	12.45	12.45	12.45
First Floor	12.45	12.45	12.45	12.45
Terrace Floor	0.00	0.00	0.00	0.00
<b>Total :</b>	<b>24.90</b>	<b>24.90</b>	<b>24.90</b>	<b>24.90</b>

Building USE/SUBUSE Details

Building Name	Building Use	Building SubUse	Building Structure
A (BUILDING)	Residential	Bungalow/ Dwelling / Non Apartment	Non-Highrise

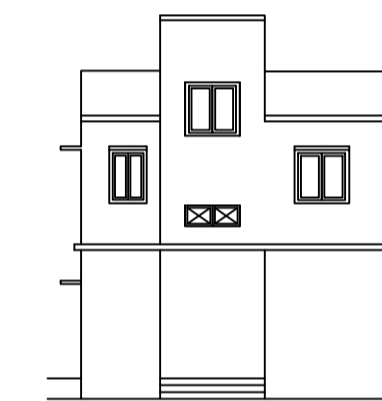
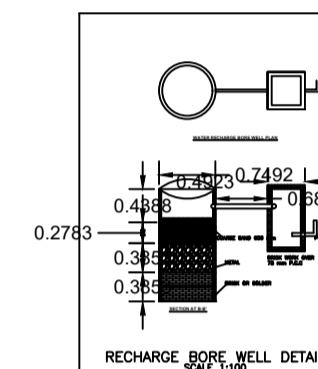
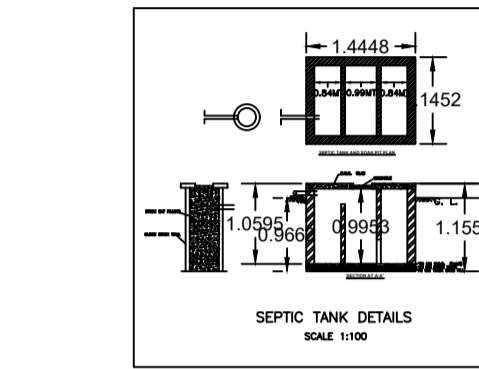

FRONT ELEVATION (SCALE 1:100)

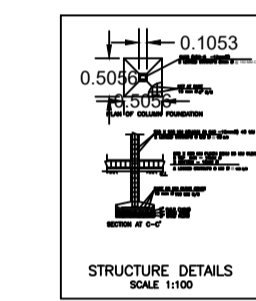

STRUCTURE DETAILS (SCALE 1:100)

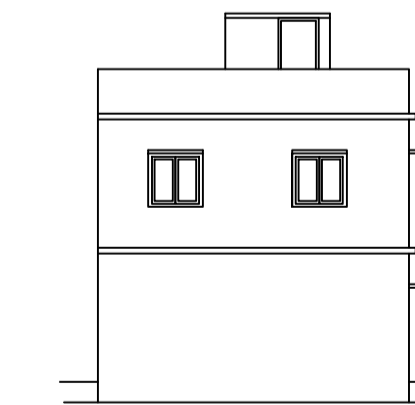

BACK ELEVATION (SCALE 1:100)

LTP NAME AND SIGNATURE	STRUCTURAL ENG'S NAME AND SIGNATURE	BUILDER NAME AND SIGNATURE	DIGITAL SIGNATURE
PANKAJ KUMAR SINGH MNNP/ENG/0006/2019			